



# HumidiPack®, HumidiPackPlus® and HumidiPackPlus® CF Steam Humidifier Systems



## Importance of Non-wetting Distance

Non-wetting distance is an important consideration in the proper application of steam humidification equipment. Shorter distances simplify the job of the design engineer by allowing proper placement of temperature and humidity controllers and other components without fear of inaccurate readings or moisture damaged equipment. Air handling unit manufacturers concerned about the “footprint” of their units and end users with limited space in mechanical rooms also benefit.

## HumidiPack®

The Armstrong HumidiPack® is a pre-fabricated steam humidifier system that is ready for insertion into the duct. The HumidiPack consists of a separator/header and multiple tube dispersion assembly when supplied for use with Armstrong steam generators. A steam supply control valve, strainer, steam trap, and a header drain trap are added when HumidiPack is used on pressurized steam. The HumidiPack accepts steam, separates entrained moisture from it, and admits it into a duct or air handler air stream via the dispersion assembly in a manner which substantially reduces non-wetting distance when compared to traditional humidifiers.

## HumidiPackPlus®

HumidiPackPlus® combines the non-wetting distance shortening performance of HumidiPack with the additional feature of steam jacketed “active” tubes. The result is a dry, uniform discharge of steam for nearly any application with a steam source from a pressurized, central supply.

Figure 86-1. HumidiPack

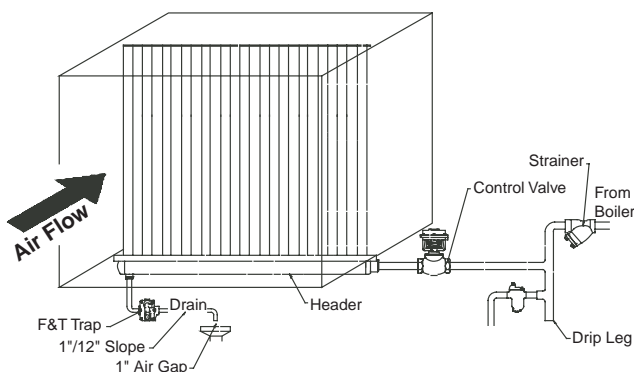

## HumidiPack® CF

HumidiPack CF offers the performance of HumidiPackPlus without the need of jacketing steam on pressurized steam applications. Typically used with a vertical header configuration, HumidiPack CF offers excellent separation of entrained moisture from steam with preheated active tubes. The entire face area is cold during periods of no demand, adding no energy to the air stream.

## Simplified Installation

The HumidiPack and HumidiPackPlus dispersion assemblies slide neatly into ductwork or air handling units. This frequently reduces the time and labor required for field installations. Units with horizontal tubes and vertical headers offer all piping on one side of the ductwork or air handler to simplify piping.

## Stainless Steel Construction

HumidiPack and HumidiPackPlus rugged designs offer stainless steel construction of wetted parts including the header/separator and dispersion assembly for a long trouble-free operating life. Tube to header joints consist of welded stainless steel rather than assembled plastic adapters with o-rings, minimizing service requirements.

## Compatible With Many Steam Sources

HumidiPack may be used with Armstrong Steam-to-Steam, gas and electric steam generating humidifiers, also with some systems including packaged boilers or central steam supply to 60 psig (4 bar). HumidiPackPlus may be used with packaged boilers or central steam supply to 60 psig (4 bar).

## Application Flexibility

Many sizes and configurations of HumidiPack and HumidiPackPlus are available to meet new installation or retrofit needs.

## Reduced Heat Gain to Duct Air from HumidiPack

Since no steam is admitted to the manifold assembly unless there is a demand for steam output, there is no heat gain to duct air when HumidiPack is not in use.

Figure 86-2. HumidiPackPlus

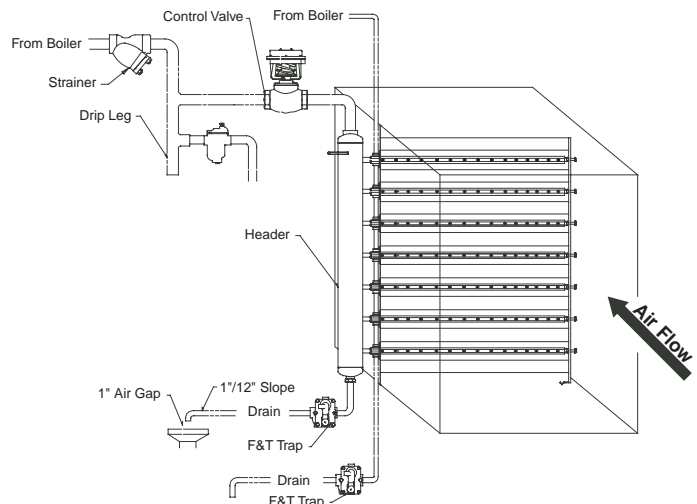

# Non-wetting Distance Considerations

## Non-wetting Distance Considerations

Non-wetting distance is an important issue in the proper design and installation of steam humidification equipment. In the humidification process, steam is discharged from the manifold as a “dry” gas. As it mixes with the cooler duct air, some condensation takes place resulting in water particles becoming entrained in the airstream. After a distance these droplets are dispersed by and absorbed into the airstream. Until they are absorbed, these particles can impinge upon any equipment they contact, adversely affecting its operation or service life.

Many applications can be satisfactorily addressed by using a single manifold with a direct steam injection humidifier (See Figure 87-1) or single dispersion tube with a steam generator

(See Figure 87-2). Frequently, however, performance and practicality dictate the use of multiple manifolds or dispersion tubes. These are field assembled (See Figure 87-3).

When non-wetting distance parameters or size limitations do not allow the use of multiple manifolds with Armstrong Series 9000 or 1000 humidifiers or multiple dispersion tubes with Armstrong steam-to-steam or electronic humidifiers, the Armstrong HumidiPack or HumidiPackPlus is used.

Please consult with your Armstrong Representative with questions regarding selection of any of these humidification products.

## Armstrong Steam Distribution Options for Air Handling Systems

Figure 87-1.

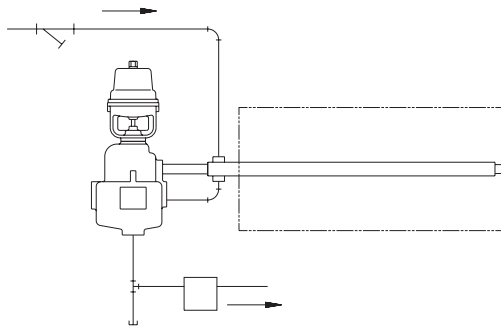

Figure 87-2.

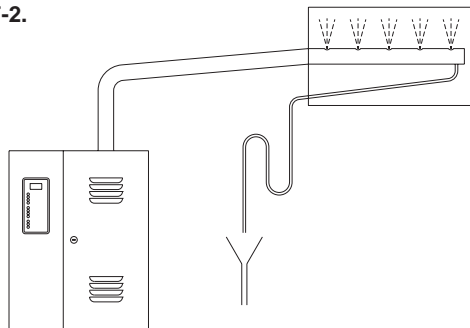
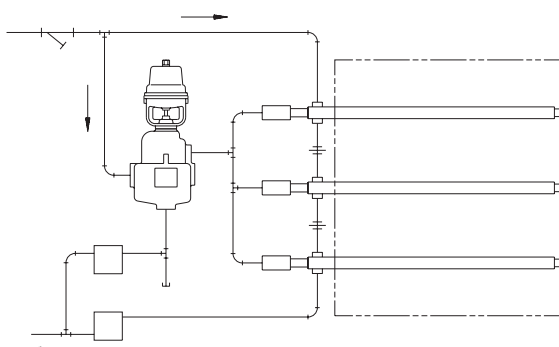

Figure 87-3.



## How HumidiPack Shortens Non-wetting Distances

Conditioned steam enters each of the dispersion tubes and flows through steam nozzles (not required on HumidiPackPlus) which extend from the center of each tube, before discharging through orifices into the airstream.

Air flow approaching the HumidiPack first encounters baffle tubes (See Figure 87-4) which influence its flow pattern and increase its velocity. Air traveling around each set of baffle tubes encounters an opposing flow of steam exiting the orifices. The result is more uniform distribution and faster absorption of moisture into the air, resulting in shorter non-wetting distances than experienced with traditional manifolds or dispersion tubes.

Figure 87-4. Mixing of Air and Steam (HumidiPack shown)

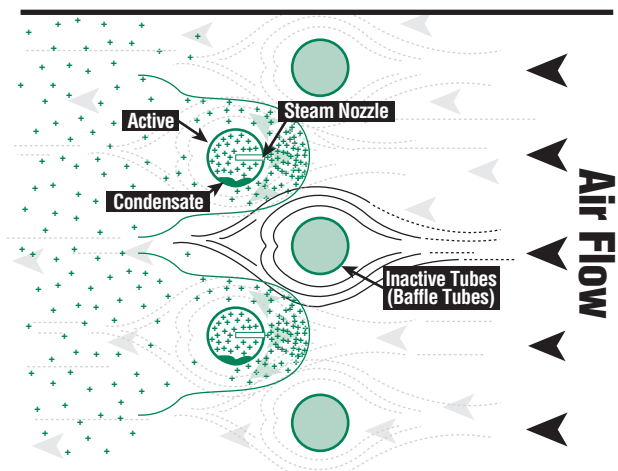



# Armstrong® HumidiPack® and HumidiPackPlus® Capacities

**Note:** Maximum operating pressure is 60 psig saturated steam. Consult factory if velocities below 375 FPM. (See Page 100 for Metric Capacities) HumidiPack, HumidiPack CF and HumidiPackPlus are customized to meet specific applications requirements. A customized unit may not necessarily be able to provide the capacities published in these tables.

**Table 88-1. Capacities (lb/hr) For 375-500 FPM Velocity - Series R and Series P (Low Velocity)**

Active Tube Length (inches)																							
Header	12	18	24	30	36	42	48	54	60	66	72	78	84	90	96	102	108	114	120	126	132	138	144
12	20	30	40	50	60	70	80	90	100	110	120	130	140	150	160	170	180	190	200	210	220	230	240
18	20	30	40	50	60	70	80	90	100	110	120	130	140	150	160	170	180	190	200	210	220	230	240
24	30	45	60	75	90	105	120	135	150	165	180	195	210	225	240	255	270	285	300	315	330	345	360
30	40	60	80	100	120	140	160	180	200	220	240	260	280	300	320	340	360	380	400	420	440	460	480
36	50	75	100	125	150	175	200	225	250	275	300	325	350	375	400	425	450	475	500	525	550	575	600
42	60	90	120	150	180	210	240	270	300	330	360	390	420	450	480	510	540	570	600	630	660	690	720
48	70	105	140	175	210	245	280	315	350	385	420	455	490	525	560	595	630	665	700	735	770	805	840
54	80	120	160	200	240	280	320	360	400	440	480	520	560	600	640	680	720	760	800	840	880	920	960
60	90	135	180	225	270	315	360	405	450	495	540	585	630	675	720	765	810	855	900	945	990	1035	1080
66	100	150	200	250	300	350	400	450	500	550	600	650	700	750	800	850	900	950	1000	1050	1100	1150	1200
72	110	165	220	275	330	385	440	495	550	605	660	715	770	825	880	935	990	1045	1100	1155	1210	1265	1320

**Note:** Use of Series R is limited to duct widths of 36".

**Table 88-2. Capacities (lb/hr) For 501-1000 FPM Velocity - Series R and Series P (Medium Velocity)**

Active Tube Length (inches)																							
Header	12	18	24	30	36	42	48	54	60	66	72	78	84	90	96	102	108	114	120	126	132	138	144
12	30	45	60	75	90	105	120	135	150	165	180	195	210	225	240	255	270	285	300	315	330	345	360
18	30	45	60	75	90	105	120	135	150	165	180	195	210	225	240	255	270	285	300	315	330	345	360
24	45	67	90	112	135	157	180	202	225	247	270	292	315	337	360	382	405	427	450	472	495	517	540
30	60	90	120	150	180	210	240	270	300	330	360	390	420	450	480	510	540	570	600	630	660	690	720
36	75	112	150	187	225	262	300	337	375	412	450	487	525	562	600	637	675	712	750	787	825	862	900
42	90	135	180	225	270	315	360	405	450	495	540	585	630	675	720	765	810	855	900	945	990	1035	1080
48	105	157	210	262	315	367	420	472	525	577	630	682	735	787	840	892	945	997	1050	1102	1155	1207	1260
54	120	180	240	300	360	420	480	540	600	660	720	780	840	900	960	1020	1080	1140	1200	1260	1320	1380	1440
60	135	202	270	337	405	472	540	607	675	742	810	877	945	1012	1080	1147	1215	1282	1350	1417	1485	1552	1619
66	150	225	300	375	450	525	600	675	750	825	900	975	1050	1125	1200	1275	1350	1425	1500	1575	1650	1725	1800
72	165	247	330	412	495	577	660	742	825	907	990	1072	1155	1237	1320	1402	1485	1567	1650	1732	1815	1897	1980

**Note:** Use of Series R is limited to duct widths of 36".

**Table 88-3. Capacities\* (lb/hr) For >1000 FPM Velocity - Series P (High Velocity)**

Active Tube Length (inches)																							
Header	12	18	24	30	36	42	48	54	60	66	72	78	84	90	96	102	108	114	120	126	132	138	144
12	46	69	92	115	138	161	184	207	230	253	276	299	322	345	368	391	414	437	460	483	506	529	552
18	46	69	92	115	138	161	184	207	230	253	276	299	322	345	368	391	414	437	460	483	506	529	552
24	69	103	138	172	207	241	276	310	345	379	414	448	483	517	552	586	621	655	690	724	759	794	828
30	92	138	184	230	276	322	368	414	460	506	552	598	644	690	736	782	828	874	920	966	1012	1058	1104
36	115	172	230	287	345	402	460	517	575	632	690	747	805	862	920	977	1035	1092	1150	1207	1265	1322	1380
42	138	207	276	345	414	483	552	621	690	759	828	897	966	1035	1104	1173	1242	1311	1380	1449	1518	1587	1656
48	161	241	322	402	482	563	643	724	804	885	965	1046	1127	1207	1288	1368	1449	1529	1610	1690	1771	1851	1932
54	184	276	368	460	552	644	736	828	920	1012	1104	1196	1288	1380	1472	1564	1656	1748	1840	1932	2024	2116	2208
60	207	310	414	517	621	724	828	931	1035	1138	1242	1345	1449	1552	1656	1759	1863	1967	2070	2174	2277	2381	2484
66	230	345	460	575	690	805	920	1035	1150	1265	1380	1495	1610	1725	1840	1955	2070	2185	2300	2415	2530	2645	2760
72	253	379	506	632	759	885	1012	1138	1265	1391	1518	1644	1771	1897	2024	2150	2277	2403	2530	2656	2783	2910	3036

\*Note: HumidiPack capacities may be modified, depending upon the application and design of unit.

The capacity tables indicate that 6' X 12' is the maximum size HumidiPack CF or HumidiPackPlus dispersion assembly. However, HumidiPack and HumidiPackPlus are designed to allow for stacking of fabricated banks or placement side by side for applications of greater size.

For applications with greater capacity requirements than shown for a specific size bank, options include:

1. An expanded duct section to allow for a sufficiently larger HumidiPack matching the capacity requirements.
2. Use of two HumidiPacks in series (where Psychometrics allow) or a primary and booster humidifier arrangement. Reference the Humidification Handbook section of this catalog or contact your Armstrong Representative for assistance.
3. Custom Series A units which are specially designed for each application's needs.
4. Use of Series 9000 direct steam injection humidifiers with an appropriate number of jacketed manifolds.

**All dimensions and weights are approximate. Use certified print for exact dimensions. Design and materials are subject to change without notice.**

# HumidiPack® and HumidiPackPlus® Orientation



**Figure 89-1. Vertical HumidiPack (Left Steam Supply)**

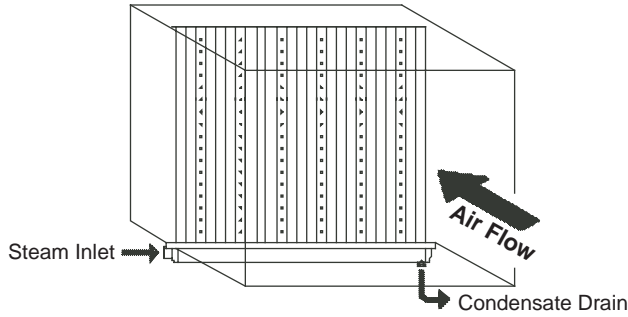

**Figure 89-2. Vertical HumidiPack (Right Steam Supply)**

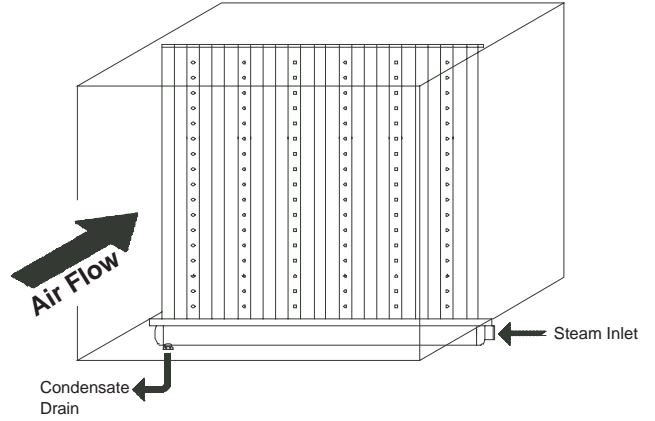

**Figure 89-3. Horizontal HumidiPackPlus (Left Steam Supply)**

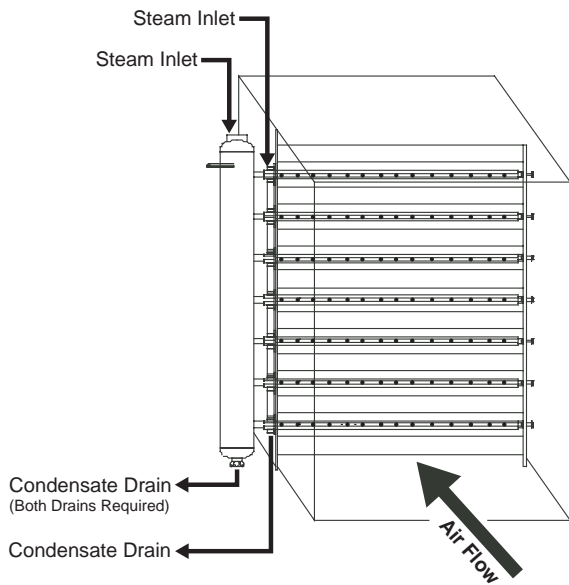

**Figure 89-4. Horizontal HumidiPackPlus (Right Steam Supply)**

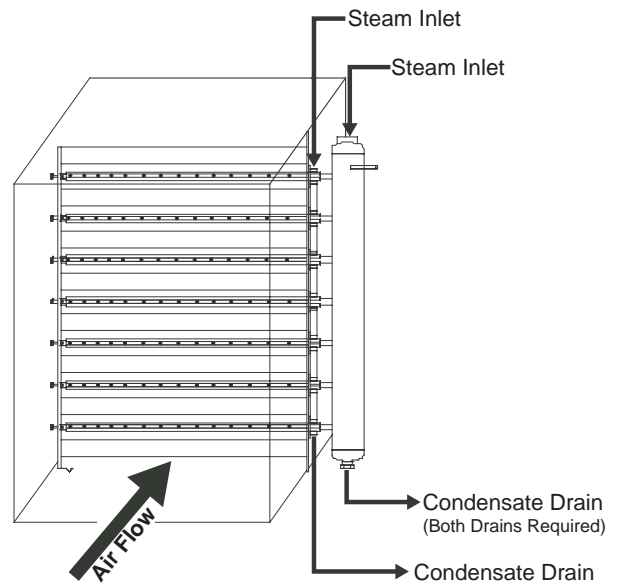

Note: Horizontal HumidiPack and HumidiPack CF orientation similar.



# HumidiPack and HumidiPackPlus Selection and Ordering Procedure

If the parameters of your application are outside the ranges for Series R or Series P in terms of capacity, the Series A units may meet your needs. Custom Series A units are specially designed for the needs of specific applications. Please consult your local Armstrong Representative with the requirements of your application.

## Steps In Selection

1. Identify the steam capacity required. Please see the Humidification Handbook section of this catalog and Armstrong's Humid-A-ware™ Humidification Sizing and Selection software, or contact your local Armstrong Representative for assistance.
2. After determining the airflow velocity (FPM), consult the appropriate HumidiPack capacity table. (See Page 88) Ensure that HumidiPack Series R or HumidiPackPlus Series P offers sufficient capacity for the specific duct height and width of your application. If not, a custom Series A is required.
3. Verify that the non-wetting distance and air pressure drop are acceptable by contacting your local representative or by downloading Humid-A-ware at [www.armstronginternational.com](http://www.armstronginternational.com).

## How To Order

Information required includes the following:

- Height and width of multiple tube bank
- CFM
- Maximum required steam capacity
- Maximum allowable air pressure drop (if specified)
- Duct air temperature
- Final duct relative humidity
- Non-wetting distance available

## Control Valve (If Applicable)

You may size the valve with the information found on Page 92 or Armstrong will size the valve if you supply the following:

- Steam pressure
- Required humidification load
- Specify type of control:  
Pneumatic, Electric, Electronic and Input Signal

## HumidiPack Orientation

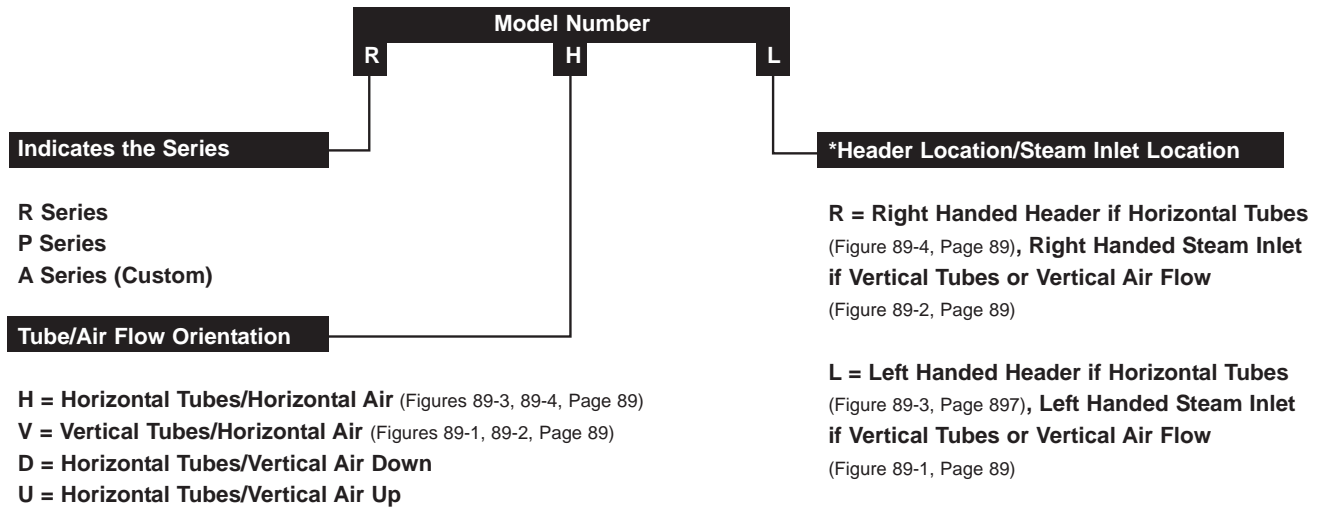

Standard HumidiPack includes (when steam source is plant steam) a strainer and inverted bucket trap for steam supply, control valve, and one header drain trap for the separator/header. HumidiPackPlus includes an additional trap to drain the dispersion tube jackets.

\*For all horizontal air flows, right and left handed orientations are determined with air flow at your back. For all vertical air flows, right and left steam inlet locations are determined by looking at the unit with airflow at your back.