



HumidiClean Series HC-6000 Humidifier

Revolutionary ionic bed technology that carries a lot of weight



The Ionic Bed. The Final Resting Place Of Ordinary Humidifiers.

Brace yourself. The Armstrong HumidiClean™ is going to change everything you know about humidifiers. The process starts with an extraordinary technology that will make traditional humidifiers obsolete. Leave them dead in their tracks, you might say.

The ionic beds you see on this page are made of a fibrous medium: the ionic bed. There are six such beds per tank in a HumidiClean humidifier (more in the Models HC-6500 and HC-6700). They attract solids from the water as its temperature rises – minimizing the buildup of solids on inner tank walls and heating elements. So you have a humidifier that stays clean except, of course, for the ionic beds. And once they have absorbed their capacity of solids, the unit even tells you to change them. It takes about 15 minutes and is absolutely hassle free.



See For Yourself How Much HumidiClean Could Save Over Traditional Units

As Table 1-1 illustrates, maintaining a HumidiClean with patented ionic bed technology is more economical than caring for either traditional cleanable or non-cleanable electronic units. When you combine costs for labor and materials and calculate the differences for seasonal maintenance, the new Armstrong HumidiClean is the obvious winner.

But to get an idea of just how big your advantage could be, multiply your savings by the number of units you have and project your answer over a few years. Can you think of a better reason to choose HumidiClean? We can't either, but we can think of several more reasons.

Table 1-1. Maintenance Cost Comparison

Maintenance cost comparison for a humidifying season using Model HC-6100. Results may vary depending on your parts and labor costs.

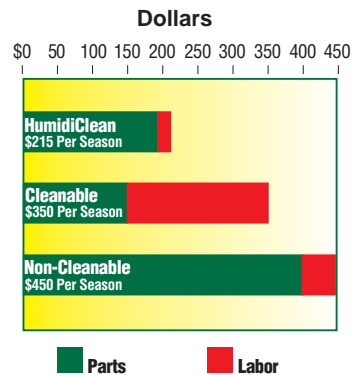

HumidiClean Passes No Current Through Water

HumidiClean's resistance-type design has a proven track record for safety. Totally different compartments keep plumbing completely separated from electrical components.

In addition, Armstrong has built several other safety features into HumidiClean. These include a key-locked access door, password protected programmable keypad, diagnostic indicating LCD display, continual-checking diagnostic routines, high- and low-water level detection, internal tank temperature sensing, overcurrent protection and connections for a Class 2 alarm device.

HumidiClean uses submersed electric heating elements to generate steam. In other words, water quality or conductivity do not affect the unit's ability to generate full output on demand. Although normally used with tap water, HumidiClean can, upon request, be installed with deionized, demineralized, softened or reverse osmosis water sources. Said another way: You get the benefit of a humidifier capable of operating over a wide range of water quality without frequent replacement of parts or bothersome, messy cleaning.

Less Scale Means Greater Efficiency

Capacity is the first victim of the scale that quickly builds up in traditional evaporative or steam-generating humidifiers. As scale gathers in the pan or on heating elements or electrodes, output declines. This gradually leads to a loss of humidity control. From this point on, things get steadily worse – until cleaning or the replacement of parts occurs.

HumidiClean with its remarkable ionic bed technology builds up deposits on its ionic bed inserts instead of tank walls or heating elements. As a result, it operates efficiently longer, its tank stays cleaner longer, and it maintains nearly maximum output throughout its service life.

Ionic Bed Technology Saves Energy

Because of carbonate buildup, most humidifiers drain every 20-45 minutes. HumidiClean's ionic beds attract these carbonates from water, so the primary reason to drain the tank

is to eliminate sodium. Since this is typically only necessary approximately once every 12 hours, the unit wastes much less hot water, thereby saving energy dollars.

HumidiClean Series HC-6000 Offers Enhanced Control of Room RH

HumidiClean uses SCR controls as standard on all units for full modulation of steam output. The humidifier's responsiveness to increased demand is enhanced through the use of an aquastat to maintain a minimum water temperature in the tank during short periods of no demand. The unit also modulates fill of makeup water into the tank to prevent reduction of steam output during the fill cycle for consistent and responsive output of produced steam.

HumidiClean Communications Capability

HumidiClean Series HC-6000 offers native MODBUS communications protocol as well as a Class II alarm circuit for monitoring purposes. Optionally, HumidiClean may be ordered to operate with either BACnet or LonWorks protocols.

Why Humidify?

As the temperature of indoor air goes up, its relative humidity (RH) goes down. When RH falls to levels commonly found in heated indoor environments, moisture-retaining materials such as wood, paper, textile fibers and a wide range of food and chemicals begin to deteriorate.

Dry air can also increase static electricity buildup, potentially impacting production or the use of office equipment. Computer rooms, printing operations, clean rooms and laboratories are especially sensitive to static charges due to dry air. Low RH also affects indoor air quality.

Steam is virtually a sterile medium offering many sanitation benefits over other types of humidification. It is recommended for essentially all commercial, institutional and industrial applications.

Ionic Bed Technology



New ionic bed



After 400 hours



After 800 hours

These microscopic photos show how the ionic bed fibers (magnified 52.5X) collect solids throughout their service life. A new ionic bed weighs approximately 1/3 pound. When it reaches its capacity, an ionic bed may weigh more than 2-1/2 pounds. A light on the control panel indicates when to replace HumidiClean's beds.

When power is supplied to the unit, the water fill valve energizes, and water enters the tank. Once the level reaches the low-water switch, the heating elements are energized (assuming there's a call for steam output). The unit continues to fill until the high-water switch is energized. The humidifier then produces steam in response to the humidistat's input signal. The tank will fill at regular intervals if all conditions remain constant. Periodic tank drainage is based on active time of the heating elements, but may be field-adjusted to water conditions.

The HumidiClean power module accepts a proportional signal and, in response, pulses power to the heating elements to provide fully modulated output. Steam output is continuously adjusted to satisfy necessary humidity requirements.

The standard HumidiClean includes the Armstrong modulating control humidistat with a 0-10 Vdc control signal. The unit is field-adjustable to accept any of the following common control signals as the main control signal: on/off (SPST relay), 0-10 Vdc, 4-20 milliamp, 0-5 Vdc. Additional input terminals are provided for on/off air flow and duct high-limit humidity controls.

Completing A Service Life Cycle

After the ionic beds have absorbed 90% of their capacity, the LCD display will flash the "EOL" (end of life) message. (See control panel photo.) If the HumidiClean is not serviced by replacing the ionic beds and re-setting the EOL, the unit will continue to produce steam on demand for the remaining 10% of ionic bed capacity. During this period, the unit will display a flashing "EOL" message. After the ionic beds have reached 100% capacity, the unit will shut down by draining the tank and will not respond to any call for humidity. Servicing the unit is now required. The service life cycle is field-adjustable to accommodate varying water quality and the specifics of the individual application.

Simple Bed Removal

Toggle from "STEAM GENERATION" on the LCD to "MANUAL DRAIN". This will cause the unit to drain. When this drain is complete, turn the main power off at the disconnect. Use caution as tank will still be quite warm. Remove screws from outer cover. Remove wingnuts from access panel. Remove old beds by pulling them up and off the holding pins in

the tank, sliding them out through the access opening. Further cleaning of the tank or heating element surface is typically not required.

Install new beds in the same manner, sliding them through the access panel and positioning them on the holding pins. After all beds have been replaced, replace the tank access panel and outer cover. Turn the power on at the main power disconnect. Toggle to and reset EOL. Unit will fill with water and return to normal operation. Total service time is usually no more than 15 minutes. (Used ionic beds contain no environmentally hazardous material and may simply be thrown away.)

Drying Cycle

If there is no demand for steam for a continuous 72-hour period, HumidiClean initiates a routine to dry ionic beds by draining and energizing the heating elements for short intervals. This drying cycle eliminates standing water concerns and improves indoor air quality.

Series HC-6000 Control Panel

The HumidiClean control panel is designed to quickly and simply display operating conditions. If an error is detected, a diagnostic display indicates the specific condition.



Service As Easy As One, Two, Three



Step 1. Remove HumidiClean outer cover and remove tank access panel. Remove the old ionic bed inserts.



Step 2. Install new inserts in place of the old ones.



Step 3. Reinstall tank access panel and outer cover. Restart HumidiClean.

Selection and Ordering Procedure

Consider the following factors to select and order the proper unit.

1. Compute the capacity required.

You must compute the maximum amount of moisture required to determine that HumidiClean is properly sized for service.

For detailed information on calculating humidification loads, refer to the Humidification Engineering section of this catalog or Armstrong's Humid-A-ware™ humidification sizing and selection software. Both may be downloaded from Armstrong's web site at www.armstrong-intl.com. Humidification loads are generally sized on a worst-case basis where design conditions exist for a limited time and do not require a safety factor. HumidiClean is designed to drain infrequently, because accumulation of tank solids is not as problematic as with other humidifiers. This conserves water and energy. There will be a short period during this drain cycle when there will be no steam output. Consult your Armstrong Representative or the factory if this poses a control problem for your system.

Example: Assume the humidification load is 38 lbs/hr (17.3 kg/hr) and available power supply is 480 volt/3 phase. Referring to Table 8-3, Page 8, we find a 15 kW Model HC-6100 HumidiClean is required. The branch circuit should be rated for 25 amps. See Table 8-2, Page 8.

2. Specify electrical characteristics of unit required.

Specify the voltage, kW, phase and cycles for unit on the order. Determine total amperage for installation purposes.

3. Specify the humidity level and range.

The standard Armstrong humidistat is 0-10 Vdc control and is adjustable by a front-mounted dial from 5-95% RH. Specify room or duct type humidistat. Or you may provide your own humidistat and/or controller. If you are providing your own controller, specify control signal type.

4. Use proper connecting materials.

Two short hose cuffs per dispersion tube are provided to be used with 2" (nom.) hard copper tube to connect the tank to the steam dispersion tube (if applicable). Armstrong recommends

using insulated copper tubing. The maximum recommended distance is 40 feet (12 meters) of equivalent length copper tubing. See Installation, Operation and Maintenance Bulletin 539 for additional guidelines.

5. Specify spare ionic bed inserts.

If HumidiClean is going to be in continuous service on a year-round basis, Armstrong recommends the purchase of a spare set of beds.

Duct Unit

6. Specify steam dispersion tube (Table 4-1).

Select the proper steam dispersion tube that meets the duct requirements. As an example, if the duct in which you are installing the humidifier has a width between 17" and 22", you should use the steam dispersion tube(s) D-1.5 (DL-1.5 for HC-6300, HC-6500 or HC-6700).

Alternatively, specify HumidiPack™ and indicate the following:

- Duct height and width
- CFM
- Duct air temperature
- Final duct RH%
- Non-wettable vapor distance available
- Maximum allowable air pressure drop (inches W.C.)

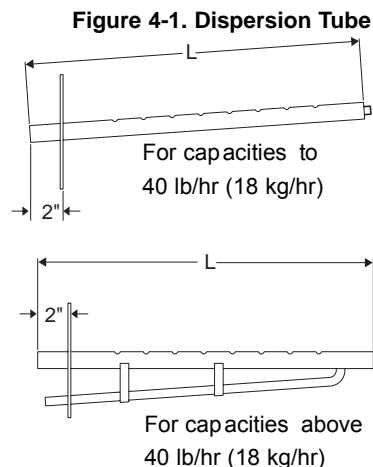

Table 4-1. Selecting Proper Steam Dispersion Tube

Steam Disp. Tube Model #		Steam Disp. Tube Length		Duct Width				Weight	
HC6100, HC6100DI	HC-6300, HC-6300DI, HC-6500, HC-6500DI, HC-6700, HC-6700DI			Min.		Max			
		in	mm	in	mm	in	mm	lb	kg
D-1	DL-1	12	304	11	279	16	406	3	1.4
D-1.5	DL-1.5	18	457	17	432	22	559	3	1.4
D-2	DL-2	24	609	23	584	34	864	4	2
D-3	DL-3	36	914	35	889	46	1168	6	3
D-4	DL-4	48	1219	47	1194	58	1473	8	3.6
D-5	DL-5	60	1524	59	1499	70	1778	9	4
D-6	DL-6	72	1829	71	1803	82	2083	10	4.5
D-7	DL-7	84	2133	83	2108	94	2388	11	5
D-8	DL-8	96	2438	95	2413	106	2693	12	5.5
D-9	DL-9	108	2743	107	2718	118	2998	13	6
D-10	DL-10	120	3048	119	3023	130	3302	14	6.4

HC6100, HC6100DI Model "D" Diameter is 1-1/2".

HC6300, HC6300DI, HC6500, HC6500DI, HC6700, HC6700DI Model "DL" Diameter is 2-3/8".

Models HC6500 and HC6700 require a minimum of (2) dispersion tubes.

All dimensions and weights are approximate. Use certified print for exact dimensions. Design and materials are subject to change without notice.



Armstrong® Selection and Ordering Procedure, continued...

7. Specify water source.

Specify if the service will include tap, deionized, demineralized, softened or reverse osmosis water.

8. Specify options required.

- **Duct high-limit humidistat.** (Recommended). You may order a duct high-limit stat. A typical setting for the high-limit stat is 85% RH. Stat opens when relative humidity exceeds settings. A modulating high-limit stat is also available for VAV systems.

- **Fan interlock.** (Recommended). You may order a duct pressure switch to activate the humidifier by sensing air flow in a duct system. The pressure switch prevents humidifier operation if there is insufficient air movement in the duct system.

Area Unit

9. Specify a fan package for each HumidiClean.

The EHF-3 offers a remote mounted, direct area discharge option for use with HumidiClean (See Figure 5-3). EHF-3 offers capacities to 120 lbs/hr (54 kg/hr). A minimum of two EHF-3 fan units are required for Model HC-6500 or HC-6700.

Figure 5-1. HC-6100 or HC-6300 Duct Type Distribution

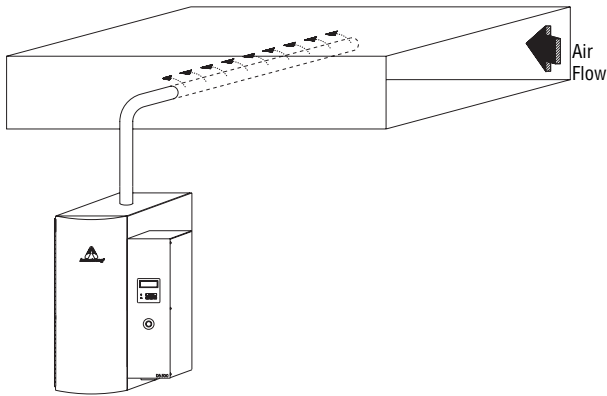

Figure 5-2. HC-6100 or HC-6300 with Duct Located below HumidiClean

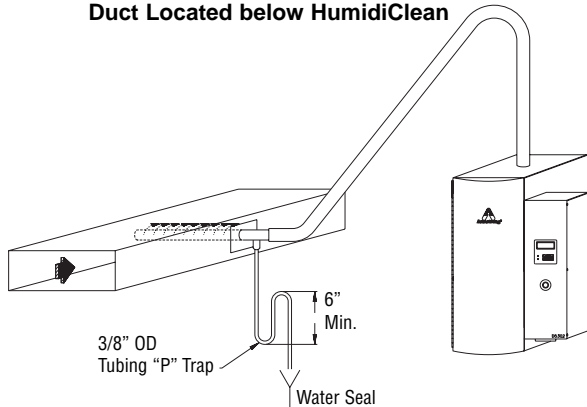

Figure 5-3. HC-6100 or HC-6300 with EHF-3 Fan Package Mounted on Wall

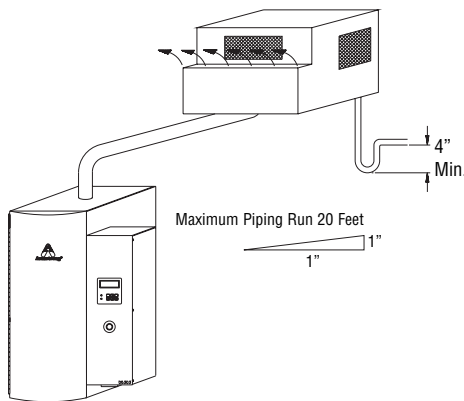

Figure 5-4. HC-6100 or HC-6300 HumidiClean Piped to HumidiPack

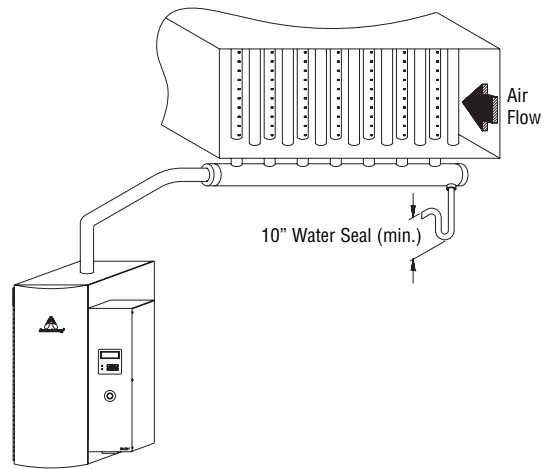
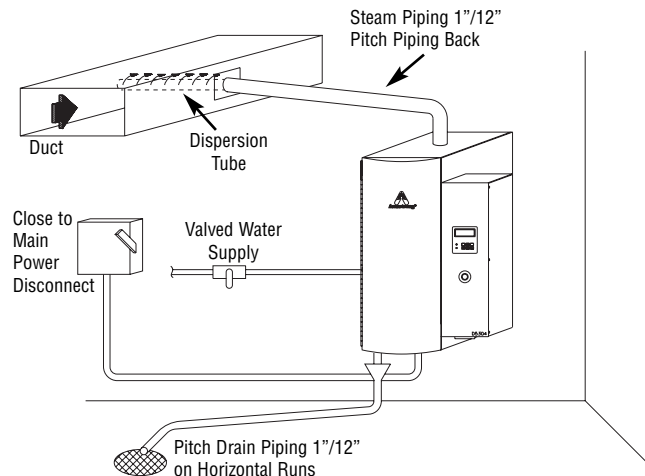

Figure 5-5. HC-6100 or HC-6300 General Installation Concept



Installation Concepts

Electronic steam humidifiers must be installed in locations that allow routine inspection and accessibility for maintenance operations.

Do not place electronic steam humidifiers in locations where unusual instances of malfunction of the humidifier or the system might cause damage to non-repairable, unreplaceable or priceless property.

Duct Type Distribution

Where an existing duct system is available, steam is commonly discharged into the duct through a dispersion tube. Selection of the dispersion tube should meet the duct requirements in Table 4-1, Page 4. If the steam dispersion tube is to be located below the humidifier, install a drip leg with water seal (See Figure 5-2, Page 5).

Alternative for Shortened Non-Wettable Vapor Trail... HumidiPack™

Use of a traditional dispersion tube (See Figures 4-1, Page 4, 5-1 and 5-2, Page 5) typically provides satisfactory non-wettable vapor trail performance in duct applications with HumidiClean. However, for applications with particularly limited downstream absorption distance, HumidiPack may be considered. HumidiPack is a prefabricated separator/header and multiple dispersion tube assembly (See Figures 5-4, Page 5, and 6-1). It provides uniform distribution and a shortened non-wettable vapor trail. Refer to Page 82 of Bulletin 596 or contact your Armstrong Representative for more information.

Area Distribution Method

The Armstrong EHF-3 fan package provides humidity distribution where an air handling system is not available. The fan package (See Figure 5-3, Page 5) is designed to be hung on a wall to operate as a remote-mounted, direct area discharge option for use with HumidiClean. The EHF-3 incorporates a blower rated at 120 V-2.90 amps. CFM rating is 465. The standard fan package requires a separate 120 volt power supply. The EHF-3 can be used (upon request) with power supplied to HumidiClean through a step-down transformer.



Note: A minimum of two EHF-3 fan units are required for Models HC-6500 and HC-6700.

Note: Models HC-6500, HC-6500DI, HC-6700 and HC-6700DI are shipped as freestanding units. They are not intended to be wall mounted.

Note: For all Series HC-6000 units: Please contact factory for duct applications offering high static pressure (>4" W.C.) or velocities over 2,000 FPM. Avoid placing dispersion tubes in downward, high-velocity airflow. Please contact your local Armstrong representative with questions.

Figure 6-1.
HC-6500 or HC-6700 HumidiClean Piped to HumidiPack

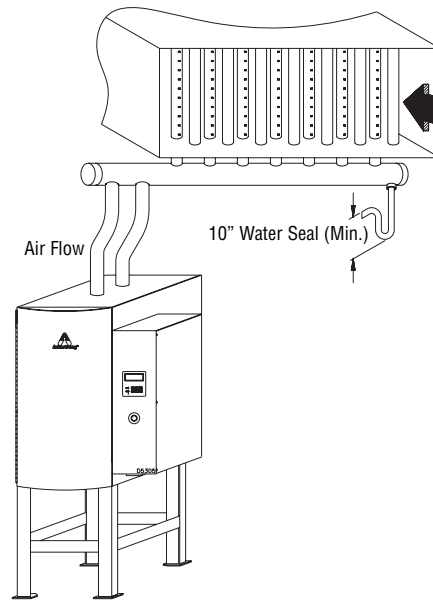
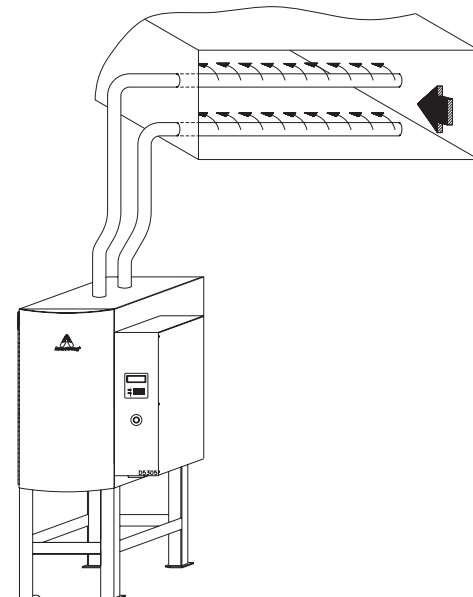

Figure 6-2.
HC-6500 or HC-6700
Duct Type Distribution with Dispersion Tubes





Suggested Specification for HumidiClean™ Series HC-6000

Steam humidifier for steam distribution of humidity (steam vapor) into air handling system or directly into space shall be of the self-contained, electrically controlled design.

- A. Vapor shall generate steam from demineralized, deionized, reverse osmosis, softened, or ordinary tap water (specify DI model for DI or RO water)
- B. Humidifier shall utilize disposable ionic bed inserts for tap water service to attract solids from boiling water. Ionic beds assist in ensuring control through responsive and consistent steam production regardless of water quality and minimize downtime required for tank cleaning.
- C. Humidifier shall have all internal components contained in a steel cabinet with key-locked access doors to prevent unauthorized access.
- D. Humidifier shall come standard with insulated, painted tank enclosure.
- E. Humidifier shall monitor tank operating history, and display will indicate when unit needs ionic bed replacement. Service life cycle may be field adapted to match water quality.
- F. Humidifier shall have SCR modulating control to provide 0%-100% of maximum capacity. Humidifier is field adaptable to utilize onboard PID controller for use with 0-5Vdc, 0-10Vdc, 4-20mA sensors or can accept an input signal from external controller/humidistat (0-5Vdc, 0-10Vdc, 4-20mA or on/off).
- G. Tank drain shall cycle based on operating history in order to conserve water and energy. Drain cycle shall be field adjustable and drain will be tempered by the fill valve.
- H. Humidifier includes end of season drain to empty tank during 72 hours of no demand. Tank pitched to assist with complete drainage.
- I. Unit shall monitor tank water level and will shut down power to the heating elements to prevent unsafe operation upon failure of the drain system, fill system, or upon an overcurrent condition
- J. Humidifier shall utilize a thermal sensing device that senses temperature within a heating element to prevent overheating.
- K. Humidifier shall incorporate stainless steel conductance-actuated probes with Teflon insulation for liquid level control on tap water service. For deionized (DI) or reverse osmosis (RO) water, humidifier shall have float switches for liquid level control
- L. Humidifier shall include a password protected programmable keypad with backlit alphanumeric display offering menu selectable diagnostics, ionic bed service life selection, and tank drain program.
- M. Keypad functions to include:
 - a. RH Graph of previous 30 days of trend data.
 - b. Real Time Clock.
 - c. Error list log showing all previous errors experienced in past 30 days, timed stamped.
- N. Humidifier fill water line shall have an air gap to prevent back-flow (siphoning) of tank water into the potable water supply system
- O. Humidifier shall modulate fill of makeup water into tank to prevent reduction of steam output during fill cycle for consistent and responsive output of produced steam
- P. A minimum tank temperature to be maintained during short periods of no demand through use of an aquastat to improve responsiveness to increases of demand
- Q. Humidifier shall incorporate electrical terminals for installation of controlling stat/sensor, duct high-limit stat/sensor, fan interlock switch, and Class 2 alarm device
- R. Humidifier shall be supplied with integral Emergency Manual Stop for quick shut down.
- S. Humidifier shall be supplied with stainless steel steam dispersion tube(s) which provide uniform steam distribution over the entire tube length and shall be supplied at various lengths (through 10') to adequately span the widest dimension of the airstream. Alternatively, humidifier shall be supplied with HumidiPack prefabricated separator/header and multiple dispersion tube assembly designed for the application in order to shorten the non-wettable vapor trail.
- T. When applicable, humidifier shall have provisions for discharging steam vapor directly into room area using factory-available fan distribution units as an accessory. These units shall be designed for remote mounting from the humidifier.
- U. Humidifier shall be supplied with hose cuffs for connection to hard copper tube (customer supplied). Stainless steel pipe required for DI/RO water.
- V. Humidifier tank shall be constructed of 14 ga. 304 stainless steel and the heating elements shall include an incoloy sheath for tap water service or stainless steel sheath for RO (reverse osmosis) or DI (deionized) water.
- W. Humidifier is interoperable through native MODBUS communications protocol. Upon request, humidifier may be supplied interoperable through BACnet or LonWorks communications protocol.
- X. Additional options include VAV control (modulating high limit

All dimensions and weights are approximate. Use certified print for exact dimensions. Design and materials are subject to change without notice.

Physical Data, Capacities and Dimensional Drawings



Generator Tank	304 Stainless Steel	
Generator Tank Gasket	Closed Cell Silicone	
Cabinet Material	18 Ga. Steel	
Cabinet Finish	Powder Coating	
Elements	Incoloy	
Ionic Bed Material	Inert Fiber	
Ionic Bed Frame	304 Stainless Steel	
Hose Cuffs	EPDM (Ethylene Propylene) Rubber	
Dispersion Tubes	Type 18-8 Stainless Steel	
Approx. Shipping Weight	176 lbs / 80 kg	330 lbs / 150 kg
Unit Weight - Dry	154 lbs / 70 kg	286 lbs / 130 kg
Maximum Operating Weight - Full	234 lbs / 106 kg	507 lbs / 230 kg
EHF-3 Fan Package	33 lb / 15 kg	33 lb / 15 kg *

*Minimum of (2) EHF-3 fan packages are required for the HC-6500 and HC-6700 units. **Consult factory when applying EHF-3 fan packages with Model HC-6700.**

Nominal Amp Rating	Wire (Gage)	MM2	Circuit Breaker
1 - 12	14	3	15
13 - 15	12	4	20
16 - 20	10	6	25
21 - 24	10	6	30
25 - 32	8	10	40
33 - 40	8	10	50
41 - 48	6	16	60
49 - 64	4	25	80
65 - 80	3	35	100
81 - 100	1	50	125
101 - 120	0	50	150
121 - 140	0	70	175
141 - 160	0	95	200

Voltage (Vac)	Models HC-6100 and HC-6100DI			Models HC-6100 and HC-6100DI				Models HC-6300 and HC-6300DI				
	3 kW Unit			9 kW Unit		15 kW Unit		18 kW Unit		30 kW Unit		
	Nominal Amps	Steam Output		Nominal Amps	Steam Output	Nominal Amps	Steam Output	Nominal Amps	Steam Output	Nominal Amps	Steam Output	
	Single Phase	Three Phase	lb/hr (kg/hr)	Single Phase	Three Phase	lb/hr (kg/hr)	Three Phase	lb/hr (kg/hr)	Three Phase	lb/hr (kg/hr)	Three Phase	lb/hr (kg/hr)
208	13.3	7.7	8.3 (3.8)	39	23	24 (11)	37	40 (18)	46	48 (22)	74	80 (36)
240	12.9	7.5	9.0 (4.1)	38	22	27 (12)	36	45 (20)	44	54 (25)	72	90 (41)
400	—	4.7		—	14		23		28			
480	—	3.8		—	11		18		22			
600	—	3		—	9		15		18			

Note: Capacities may vary in proportion to power supply.

Voltage (Volts)	Model HC-6500 and HC-6500DI																	
	30 kW Unit			33.5 kW Unit			40 kW Unit			45 kW Unit			48 kW Unit			50.3 kW Unit		
	Nominal Amps	Steam Output		Nominal Amps	Steam Output		Nominal Amps	Steam Output		Nominal Amps	Steam Output		Nominal Amps	Steam Output		Nominal Amps	Steam Output	
	Three Phase	lb/hr	kg/hr	Three Phase	lb/hr	kg/hr	Three Phase	lb/hr	kg/hr	Three Phase	lb/hr	kg/hr	Three Phase	lb/hr	kg/hr	Three Phase	lb/hr	kg/hr
208	84	90	41	—	—	—	—	—	—	125	135	61	—	—	—	—	—	—
240	—	—	—	—	—	—	96	120	54	—	—	—	—	—	—	—	—	—
400	—	—	—	51	100	45	—	—	—	—	—	—	73	144	65	77	150	68
480	—	—	—	—	—	—	—	—	—	—	—	—	58	100	45	—	—	—
600	—	—	—	—	—	—	—	—	—	—	—	—	47	100	45	—	—	—

Note: Capacities may vary in proportion to power supply.

Volts (Vac)	HC6500 and 6500DI				HC6700 and 6700DI			
	60 KW Unit		72KW Unit		67KW Unit		96 KW Unit	
	Rating Amps Three Phase	Steam Output lbs/hr (kg/hr)	Rating Amps Three Phase	Steam Output lbs/hr (kg/hr)	Rating Amps Three Phase	Steam Output lbs/hr (kg/hr)	Rating Amps Three Phase	Steam Output lbs/hr (kg/hr)
240	144	180 (82)	—	—	—	—	—	—
400	—	—	110	216 (98)	102	201 (91)	145	288 (130)
480	—	—	87		—	—	116	
600	—	—	70		—	—	93	

Note: Capacities may vary in proportion to power supply.

All dimensions and weights are approximate. Use certified print for exact dimensions. Design and materials are subject to change without notice.



Armstrong Physical Data, Capacities and Dimensional Drawings

Figure 9-1. Models HC-6100 and HC-6300

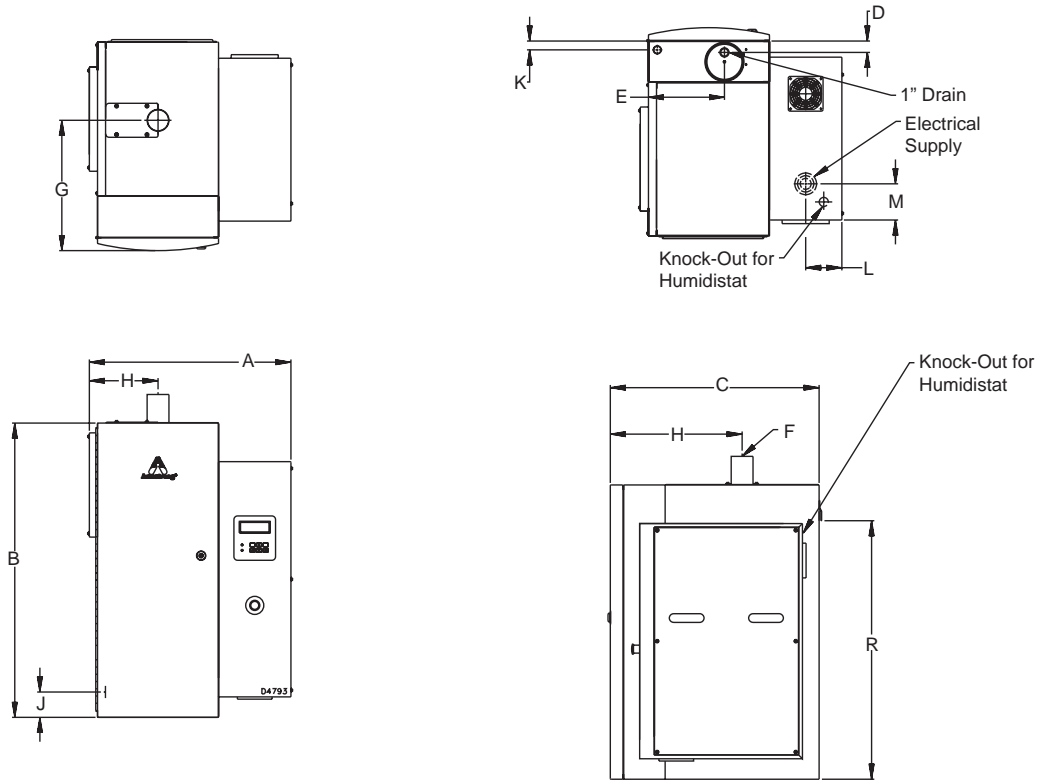

Table 9-1. Physical Data

	HC-6100 and HC-6300		HC-6500, HC-6700 and HC-6700DI	
	Inches	mm	Inches	mm
"A"-Width	21-15/16	557	26	660
"B"-Height	32-1/16	814	56-3/18	1428
"C"-Depth	22-1/3	576	32-3/32	815
"D"-Drain - Back	20	508	29-3/16	748
"E" Drain - Side	9-1/8	232	11-1/2	293
"F"-Steam Discharge Tube	2-3/8	60	2-3/8	60
"G"-Steam Outlet - Side	7-1/2	190	9-1/2	241
"H"-Steam Outlet - Front	14-1/3	364	12-7/8	328
"J"-Supply Water - Bottom	1-27/32	47	1-7/8	47
"K"-Water Supply - Front	2-13/32	61	2-3/8	60
"L"-Electrical Supply - Side	18	457	22-1/16	560
"M"-Electrical Supply - Back	10-3/16	254	16-1/4	413
"Q"-Steam Dispersion Outlets	—	—	12-3/16	310
Water Supply Connection	3/8 compression fitting	10	1/2 compression fitting	12

All dimensions and weights are approximate. Use certified print for exact dimensions. Design and materials are subject to change without notice.

Physical Data, Capacities and Dimensional Drawings



Figure 10-1. Models HC-6500 and HC-6700 — Front, Side, Top Views

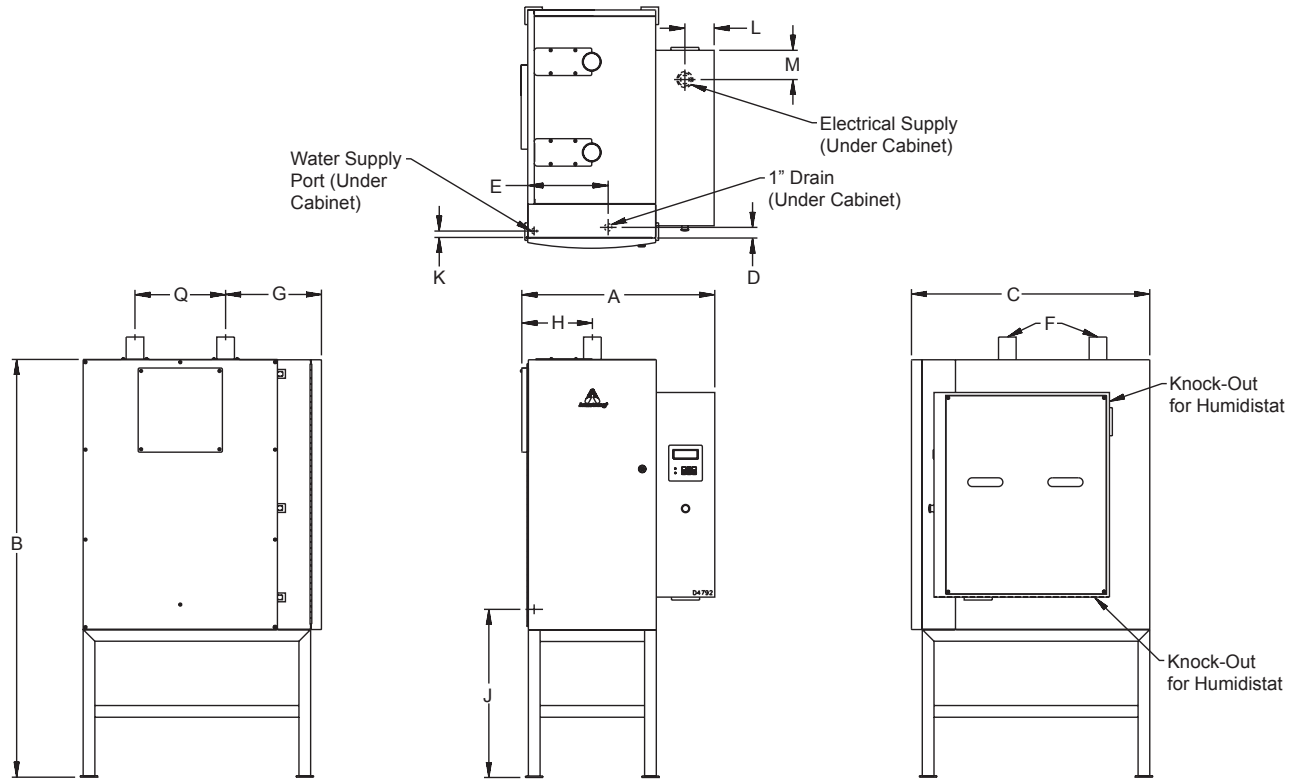

All dimensions and weights are approximate. Use certified print for exact dimensions. Design and materials are subject to change without notice.