



## Instruction & Operation Manual



**ElectroVap® HUMIDIFIERS**  
**ELMC Series**

# ELECTROVAP® ELMC

## Contents

1.	SAFETY INSTRUCTIONS	3
1.1	INTRODUCTION	3
1.2	IMPORTANT REMARKS	3
1.3	DECLARATION OF CONFORMITY	5
1.4	ROHS DECLARATION	5
2.	PRODUCT PRESENTATION	6
2.1	CHARACTERISTICS	6
2.2	SIZE	7
2.3	HUMIDIFIER COMPONENT PARTS	8
2.4	IMPORTANT INSTRUCTIONS	9
3.	INSTALLATION	10
3.1	PROCEDURE	10
3.2	WATER SUPPLY	11
3.3	DISPERSION TUBE POSITIONING	12
3.4	STEAM OUTLET	17
3.5	CONDENSATE DRAINING WITH SIPHON	18
3.6	DRAIN HOSE CONNECTION	19
3.7	ELECTRICAL CONNECTIONS	21
3.8	ELECTRICAL WIRING	23
3.9	CONTROL SIGNAL CONNECTION	32
3.10	OPTION: TRANSFORMER CONNECTION	34
4	COMMISSIONING	35
5	SYSTEM MANAGEMENT	36
5.1	USER INFORMATION MENU (READ ONLY)	36
5.2	HUMIDIFIER STATUS MENU	39
5.3	CHANGE SETTINGS MENU	40
5.4	MAINTENANCE ALERTS	43
5.5	DEFAULT MESSAGE	44
6	MAINTENANCE	47
6.1	GENERAL INFORMATION	47
6.2	STEAM CYLINDER CLEANING	48
6.3	DRAIN VALVE	50
6.4	WATER INLET VALVE	51
7	SPARE PARTS	52
7.1	HYDRAULIC PART	52
7.2	WATER INLET VALVE	54
7.3	DRAINING CIRCUIT	54
7.4	ELECTRICAL PART	55

# ELECTROVAP® ELMC






## 1. SAFETY INSTRUCTIONS

### 1.1 INTRODUCTION

You recently purchased the ElectroVap® ELMC, and we hope you enjoy this product. Thank you for the trust you place in us. The safety instructions contained in this manual are intended for specialized, qualified, and authorized personnel.

To get the best results from the humidifier, we recommend to:

- Read carefully the assembly and installation instructions in this manual;
- Keep this manual in a safe place for future reference;
- Transmit this manual in case of sale or transfer of the device, in order to guarantee the transmission of information about it;

SAFETY WARNINGS AND SYMBOLS USED IN THE MANUAL	
	<b>Danger! Caution.</b> General safety instruction, whose violation could lead to malfunctions and / or bodily harm to person and / or property damage.
	<b>Danger! High voltage.</b> There are high voltages inside the device or one of its components, the negligence of this warning can lead to serious bodily injury or death to people and / or significant material malfunctions.
	<b>Danger! High temperature.</b> The ElectroVap® ELMC uses steam during the operation and therefore surfaces and pipe-work become very hot. Ensure that equipment not sustaining high temperatures is kept away.
	<b>Electrostatic hazard.</b> The components of the device may be subject to deterioration as they are very sensitive to electrostatic discharge.
	<b>Möbius strip.</b> Some components of the device are recyclable, the user is responsible for the removal of these. Follow the recycling recommendations adapted to the materials according to the geographical area.

- If your package is damaged or missing, please make a complaint to your carrier with a receipt acknowledgment letter within 24 hours and make a declaration to your Devatec agent.
- Pictures, graphics, and values may be subject to technical changes without notice.
- Keep this instruction manual carefully, and if you have any questions that are not answered in this manual, do not hesitate to contact us, or consult your Devatec agent.

**Our team will be pleased to be of assistance!**

# ELECTROVAP® ELMC

## 1.2 IMPORTANT REMARKS

<b>GENERAL</b>	<p>This manual is a translation of the original French version. This manual contains all the details concerning the commissioning, operation, and maintenance of the device.</p> <p><b>Maintenance, service, repairs, as well as the study of the risks and dangers associated with these operations must be carried out by qualified, competent, and authorized personnel.</b></p> <ul style="list-style-type: none"><li>- Make sure that all risks or dangers are defined beforehand by an authorized person, especially for works-at-height.</li><li>- We also recommend installing a security perimeter.</li><li>- Make sure that the power supply is switched off before performing maintenance.</li><li>- Please screw periodically all the connection terminals of the power cable.</li></ul>
<b>INTENDED USE</b>	<p>This device is manufactured by Devatec is intended solely for humidification purposes, in air treatment station or in ambiance. The user undertakes to use it according to the safety instructions given in this manual.</p> <p>Improper use could result in serious hazards and damages to the user, third parties and materials.</p>
<b>STORAGE &amp; MAINTENANCE</b>	<p>The device must be stored in a dry, frost-free place, protected from shocks and vibrations. Maintenance must be carried out by at least two people or suitable lifting equipment.</p>
<b>WATER</b>	<p>Steam humidifiers can be used with potable, demineralized, or softened water. It is absolutely forbidden to inject a chemical into the hydraulic system. Make sure that the water supply pressure does not exceed 6 bar. Always be careful that the installation meets local standards.</p>
<b>ELECTRICITY</b>	<p>The user ensures that electrical installation will be carried out by an authorized technician in this field. The installer must provide the correct cable section as well as the thermal-magnetic circuit breaker protection.</p>
<b>WARRANTY</b>	<p>Devatec guarantees that its devices are one (1) year warranty.</p> <p>Devatec's liability will be limited exclusively to Devatec's repair or replacement of the part or product, excluding labor, disassembly, or installation costs. Devatec may also decide to refund the purchase price of the product or part of it, at its discretion. The non-compliance of these above recommendations, additional mounting and / or transformation with components other than those provided with the device or any use other than what is explicitly stated, shall be considered as not in compliance with the prescriptions, and will invalidate the warranty.</p>
<b>LIABILITY</b>	<p>Devatec shall be not made liable for the consequences of incorrect installation, improper use of the devices and/or their components.</p> <p>We are committed to provide you the most complete manual, although, in the air treatment field, variations are so common that the information found in this document may be subject to changes without notice.</p>

# ELECTROVAP® ELMC

## 1.3 DECLARATION OF CONFORMITY

The devices identified by serial numbers between 400 000 and 499 999, meets the requirements of the following European Directives:

2014/30/UE

2014/35/UE

<b>DEVICE TYPE</b>	Humidifier
<b>MODEL NAME</b>	ELMC
<b>MANUFACTURER</b>	Devatec 185 Boulevard des Frères Rousseau 76550 Offranville - FRANCE

We the undersigned, hereby declare that the equipment specified above conforms to the above Directive(s) and Standard(s). Valid for units with serial number starting from n° 400 001

FRAMBOT Jean-François  
General Manager  
05/01/2021



## 1.4 ROHS DECLARATION

Devatec,

Confirms that the ElectroVap® ELMC humidifier is manufactured in compliance with the following European regulations:

2011/65/UE

This guideline regulates, after July 1<sup>st</sup> 2006, the use of mercury, cadmium, lead (soldering processes), chrome VI as well as PBB and PBDE.

MINFRAY Jean-Marie  
R&D Engineer  
05/01/2021



## 2. PRODUCT PRESENTATION

### 2.1 CHARACTERISTICS

The ELMC humidifier is an electric humidifier, designed for air humidification in air handling unit. Like all the other humidifiers of the range, it is compatible with the Blower Pack.

Standard delivery includes:

1. Steam humidifier
2. Technical documentation
3. 3 hose clamps (2 for the steam hose and 1 for the drain hose)

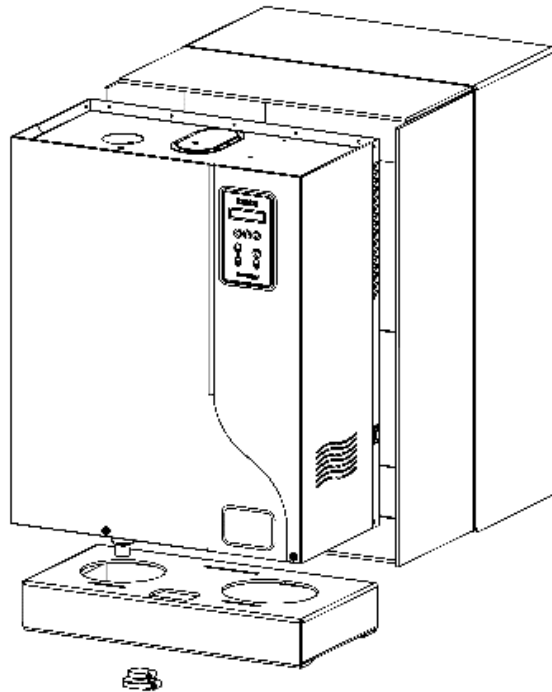


Fig. 2-1. Humidifier

#### ACCESSORIES (Not supplied)

- Stainless steel steam dispersion tubes
- ExpressPack®
- BlowerPack fan unit
- Steam and condensate hose
- Duct or room humidity sensor
- High Limit Humidistat
- Stainless steel braided hose in 3/4" FF (with gaskets) for connection to water network.
- Drain hose
- Remote information board
- Filling cup extension
- Transformer 380-690V/115-230V
- Additional cooling kit
- Outdoor protective cabinet
- Mounting bracket
- Collecting water tank
- Bluetooth kit for mobile application

# ELECTROVAP® ELMC

## 2.2 SIZE

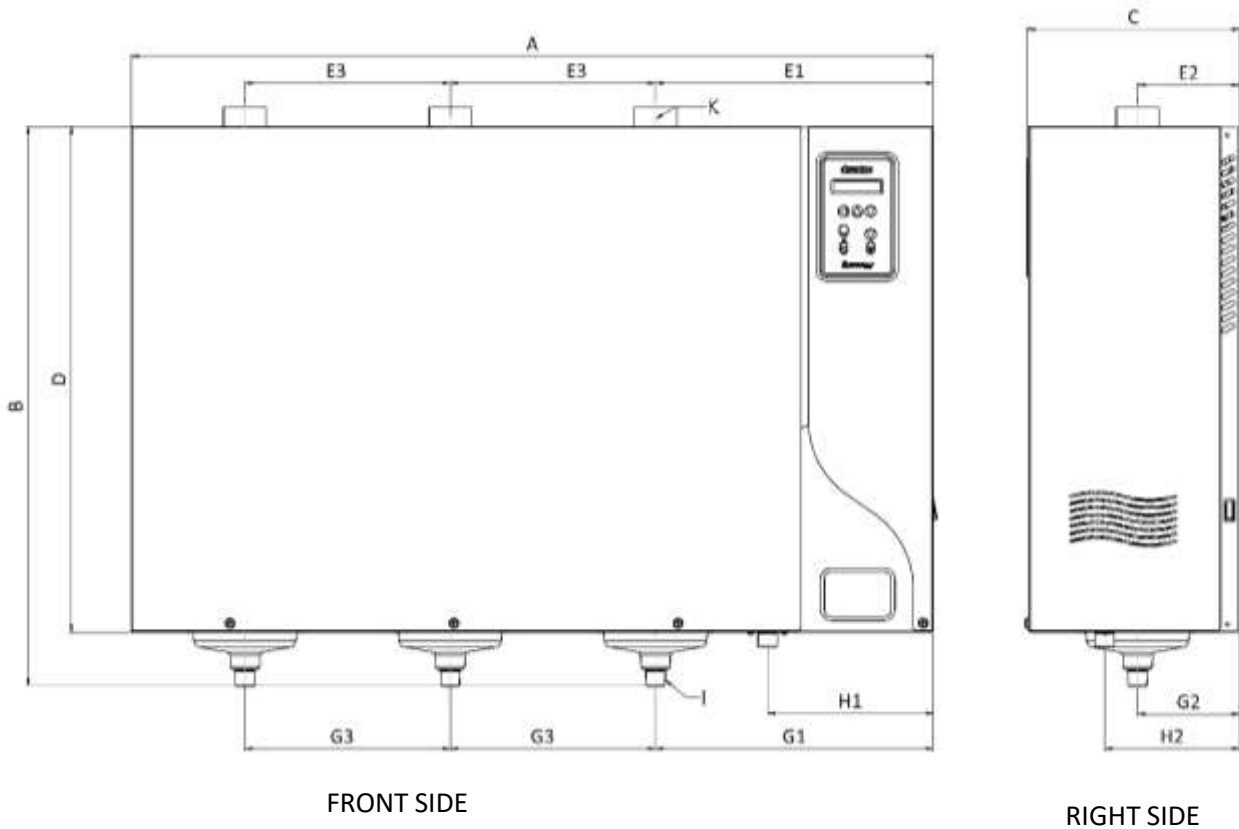


Fig. 2-2. Humidifier sizes

	ELMC 5-15	ELMC 20-30	ELMC 40-60	ELMC 90
Number of steam outputs	1	1	2	3
Dimensions [mm]				
A: Total width	469	554	794	1074
B: Total height	610	750	750	750
C: Depth	225	285	285	285
D: Height	538	678	678	678
E1: Steam outlet position	350	417	372	372
E2: Steam outlet position	111	137	137	137
E3: Distance between steam outputs			275	275
G1: Drain water position	350	417	372	372
G2: Drain water position	111	137	137	137
G3: Distance between draining water			275	275
H1: Water inlet position	222	222	222	222
H2: Water inlet position	141	181	181	181
I: Condensate outlet diameter	∅ 25	∅ 25	2 x ∅ 25	3 x ∅ 25
K: Steam output diameter	∅ 25 or 40	∅ 40 or 25	∅ 40 or 25	∅ 40 or 25
Mass [kg]				
Weight in operation	23	37	60	90
Gross weight (packed)	15	22	30	45

# ELECTROVAP® ELMC

## 2.3 HUMIDIFIER COMPONENT PARTS

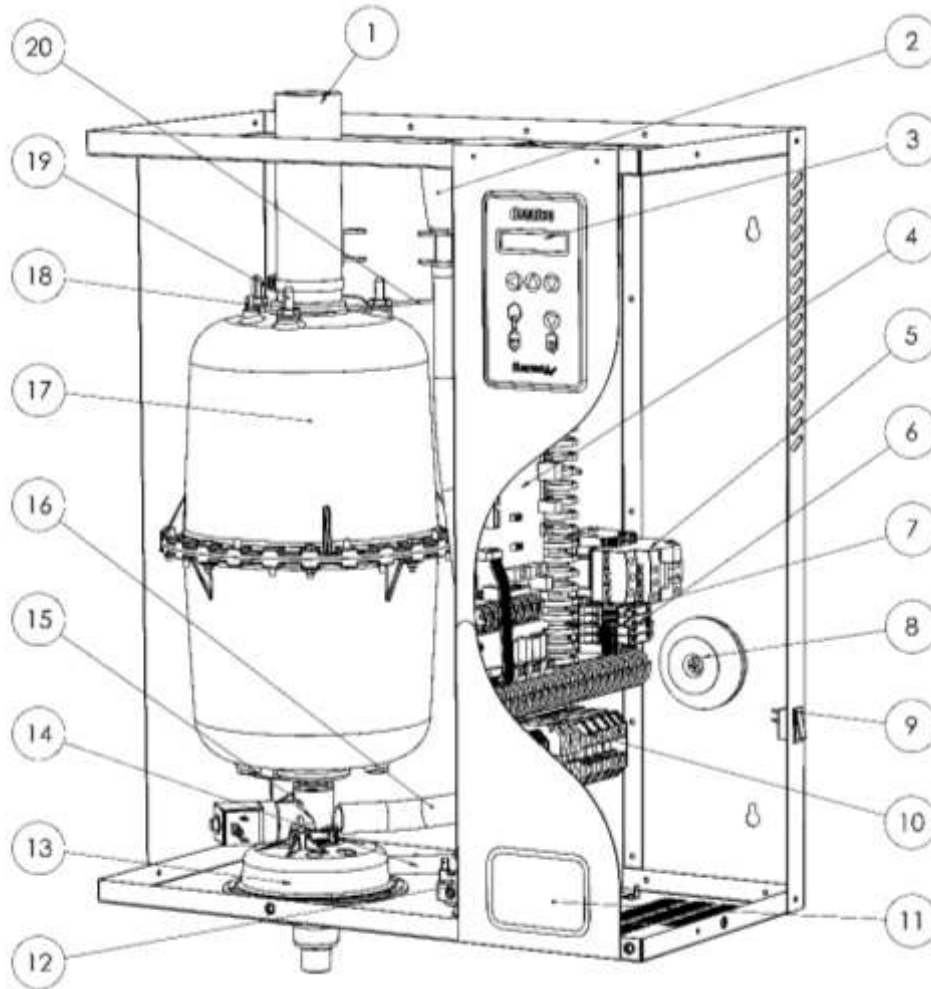


Fig. 2-3. Humidifier component parts

1	Steam hose	11	Identification label
2	Filling cup	12	Water inlet valve
3	LCD display board	13	Funnel
4	Main circuit board	14	Overflow hose
5	Power contactor	15	Drain valve
6	Fuse holders	16	Filling hose
7	3 relay board (optional)	17	Steam Cylinder
8	Transformer	18	High water level electrode
9	ON/ OFF Switch	19	Power electrode
10	Power rail	20	Cylinder retaining clip



# ELECTROVAP® ELMC

## 2.4 IMPORTANT INSTRUCTIONS

- Ambient temperature: between 5 and 40°C
- Ambient humidity: < 80% Relative humidity
- Back side: this component heats during operation (up to 60°C). Make sure that the support of the device is not made of a heat-sensitive material.
- Wall mounting: Please be careful that the support material receiving the device (pillar, wall, etc.) can support it.
- Fixation: use a fastening system adapted to the support material.
- Make sure that the mounting distances are met.

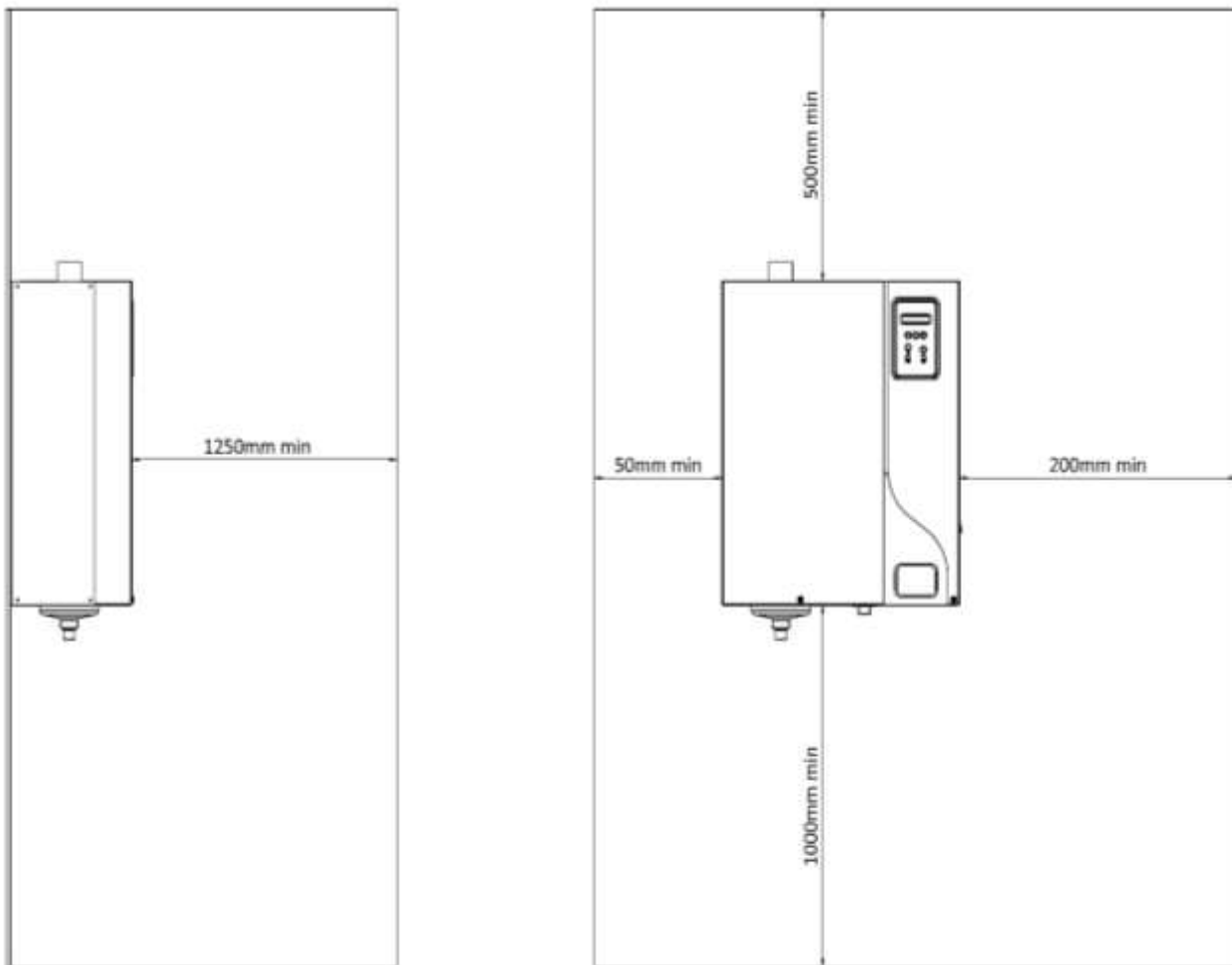


Fig.2-4. *Mounting distances*



Please read and follow the enclosed safety information and the warning labels inside the humidifier before installation or maintenance.

**Some steps can be dangerous.**

Visit our website or contact our operators for technical support.

# ELECTROVAP® ELMC

## 3. INSTALLATION

### 3.1 PROCEDURE

- Mark and drill where indicated (holes size depends on the selected dowels and support materials).
- Put the dowels in the holes.
- Screw the top screws into the dowels (M6 recommended), let them protrude by about 10 mm/0.39in.
- Hang the device to the top screws and align it vertically and horizontally with a bubble level.
- Tighten up all screws.

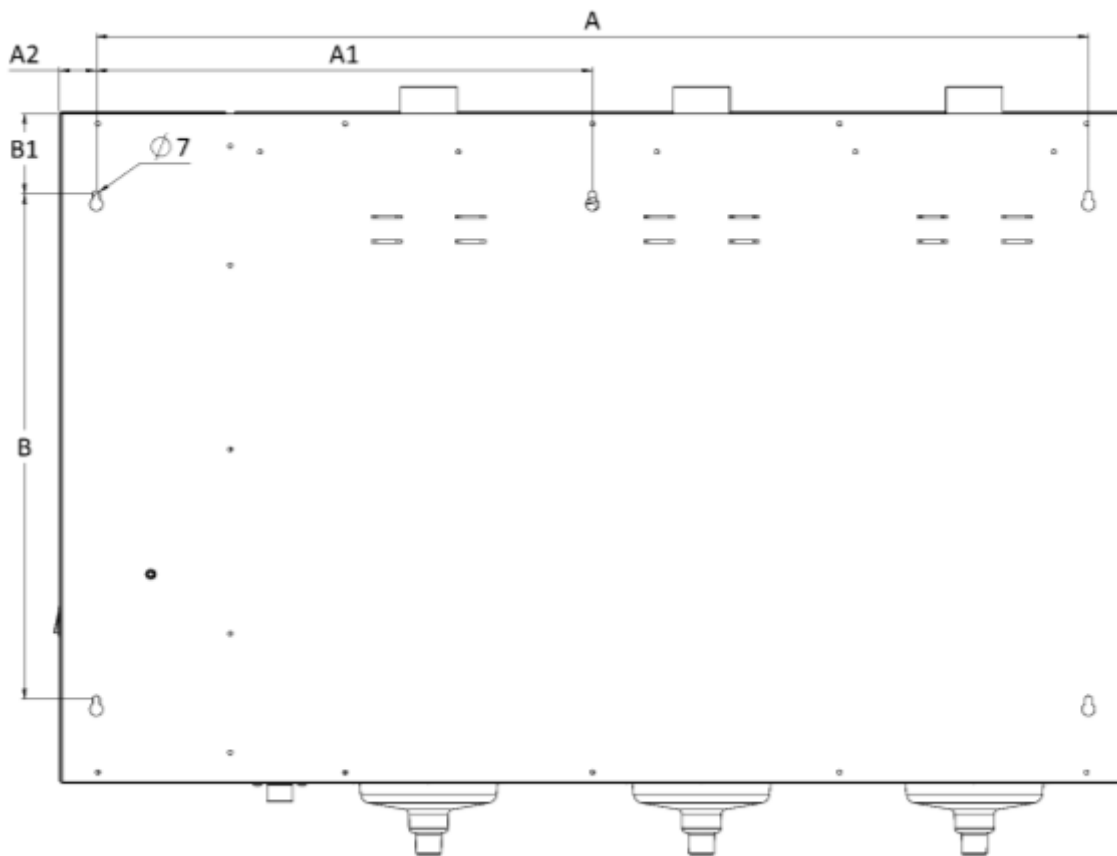


Fig. 3-1. Installation holes

	ELMC 1 SC <sup>(*)</sup>	ELMC 1 MC <sup>(*)</sup>	ELMC 2 MC <sup>(*)</sup>	ELMC 3 MC <sup>(*)</sup>
Has:	400	450	750	1000
A1:				500
A2:	35	53	23	38
B:	400	510	510	510
B1:	81	81	81	81

<sup>(\*)</sup>SC = Small Cylinder - MC= Medium Cylinder

# ELECTROVAP® ELMC

## 3.2 WATER SUPPLY

### 3.2.1 Recommendation

Our device is designed to be used with any following water type:

- ✓ drinking water (according to Directive 98/83/EEC, TH (French grade) between 0°FH and 40°FH and conductivity between 250 µS/cm and 1000 µS/cm)
- ✓ softened water,
- ✓ demineralized water, reverse osmosis water: use possible under conditions. Please contact our services

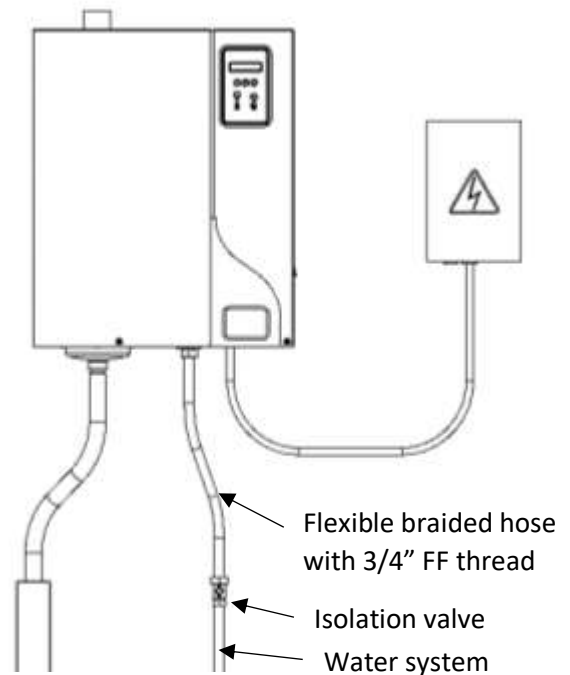


Fig. 3-2. Humidifier water supply



The demineralized water is corrosive; use appropriate piping material: stainless steel, PVC.

Softened water: Its use is not necessary, but possible. TH should be **between 0° fH and 2° fH**.  
Water analysis is recommended to determine the level of sodium chloride.  
Do not hesitate to contact our services for support.



An excess of sodium chloride may generate foam which disturbs the correct running of the humidifier.  
**It is mandatory to use a duplex softener.**  
**Max. chloride content: 80 mg/l**

### 3.2.2 Recommendations on connection

Network water pressure: The pressure must be stable and between 2 bar and 8 bar MAX. in case the water pressure exceeds 8 bar, a water regulator calve must be used.

Network water temperature: < 40 °C.

Please note that the water supply is connected at the lower part of the unit.

For easy maintenance, the water inlet valve is equipped with a filter strainer which should be checked periodically. It is essential to install an isolation valve near the humidifier to facilitate maintenance.



**OVERFLOW RISKS:** it is recommended to install a collecting water tank under the humidifiers to prevent overflow. This is essential if the unit is installed in false ceilings or above important rooms (example: museum room, showroom, laboratory etc.). Make sure the container is connected to the wastewater system.

# ELECTROVAP® ELMC

## 3.3 DISPERSION TUBE POSITIONING

### Steam dispersion tubes:

The steam from the humidifier is injected in a duct or an air handling unit via a steam dispersion tube. To obtain the best performance of the humidifier, select the longest pipe.

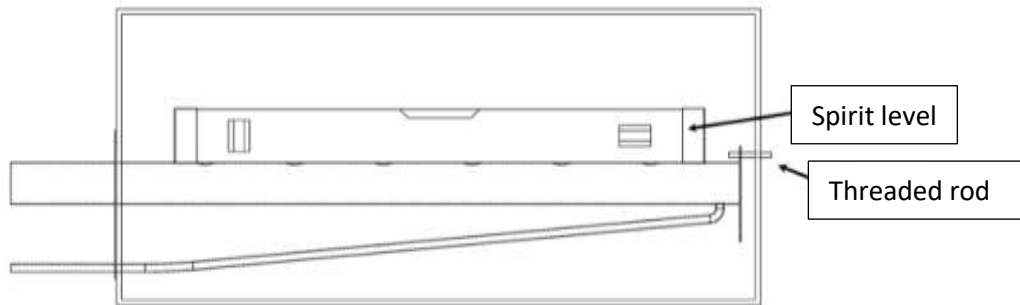


Fig. A 3-3. Steam dispersion tubes positioning

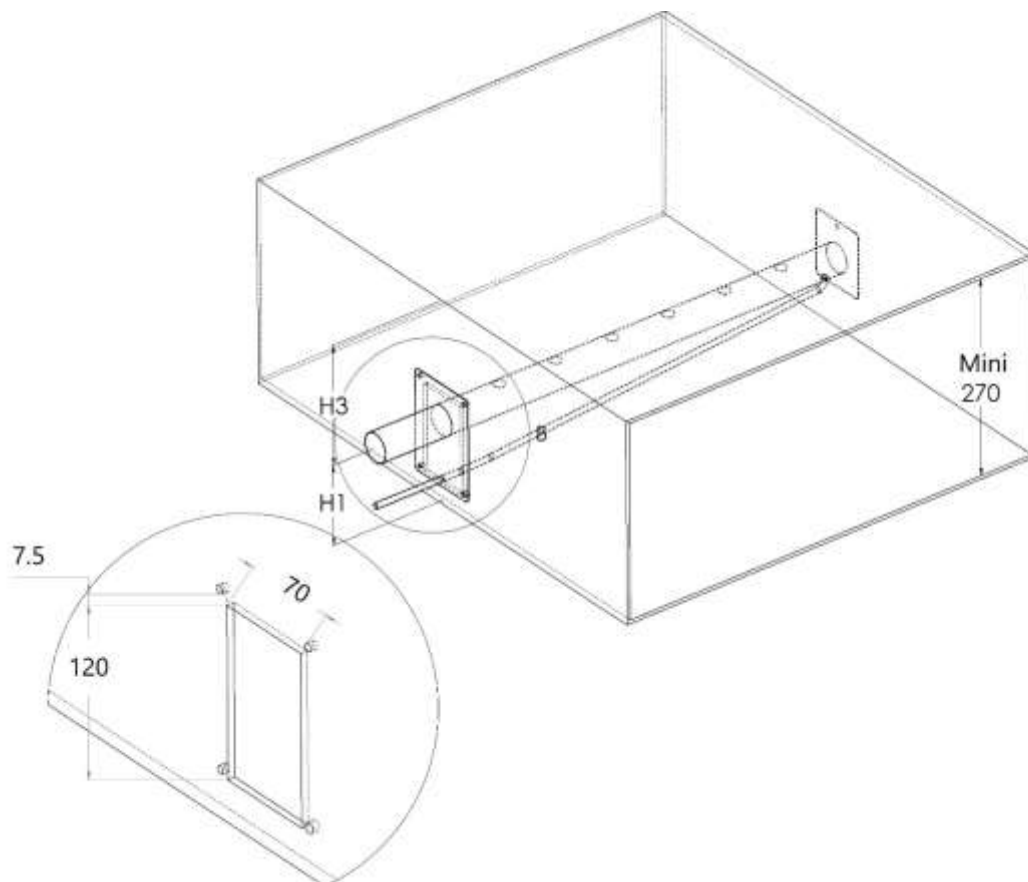


Fig. B 3-3. Hole dimension to be cut in the duct

# ELECTROVAP® ELMC

## 3.3.1 Absorption distance "D"

Make sure that the absorption distance is met in order to let the air absorb the steam dispersed by the tubes. In this absorption distance, the steam is still visible in the air stream in the form of fog. If any furniture is placed in this area, condensate may occur. For this reason, it is imperative to consider this absorption distance when placing the humidifiers.

## 3.3.2 How to calculate absorption distance « D »

In order to determine the absorption distance, the attached calculation table can be used:

- RH1 = relative humidity of air before humidification in %.
- RH2 = relative humidity of air after humidification in %.
- D mini = minimum absorption distance in meters (m).

	Inlet RH1 [%]							
	5	10	20	30	40	50	60	70
Outlet RH2 [%]	Minimum absorption distance "D" [m]							
40	0,9	0,8	0,7	0,5	-	-	-	-
50	1,1	1	0,9	0,8	0,5	-	-	-
60	1,4	1,3	1,2	1	0,8	0,5	-	-
70	1,8	1,7	1,5	1,4	1,2	1	0,7	-
80	2,3	2,2	2,1	1,9	1,7	1,5	1,2	0,8
90	3,5	3,4	3,2	2,9	2,7	2,4	2,1	1,7

This calculation table is to be used for temperatures between 20°C and 25°C (68°F to 77°F) (Maximum air speed 5m/s). For calculated distances, contact your Devatec agent.

## 3.3.3 Minimum absorption distance

The steam dispersion pipes must be positioned after the minimum specified absorption distance. Please follow the guidelines depending on the configuration of your air handling unit.

Fig. B 3-3. Before/after a fan

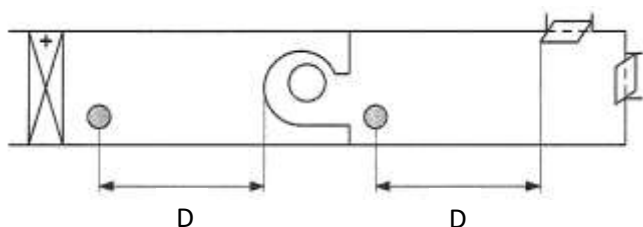
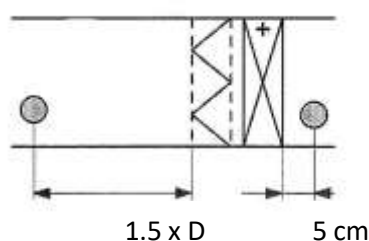


Fig. C 3-3. Before/after heating battery or filter



1.5 x D before a particle filter or absolute filter

● Dispersion tube

# ELECTROVAP® ELMC

## 3.3.4 Minimum installation distances

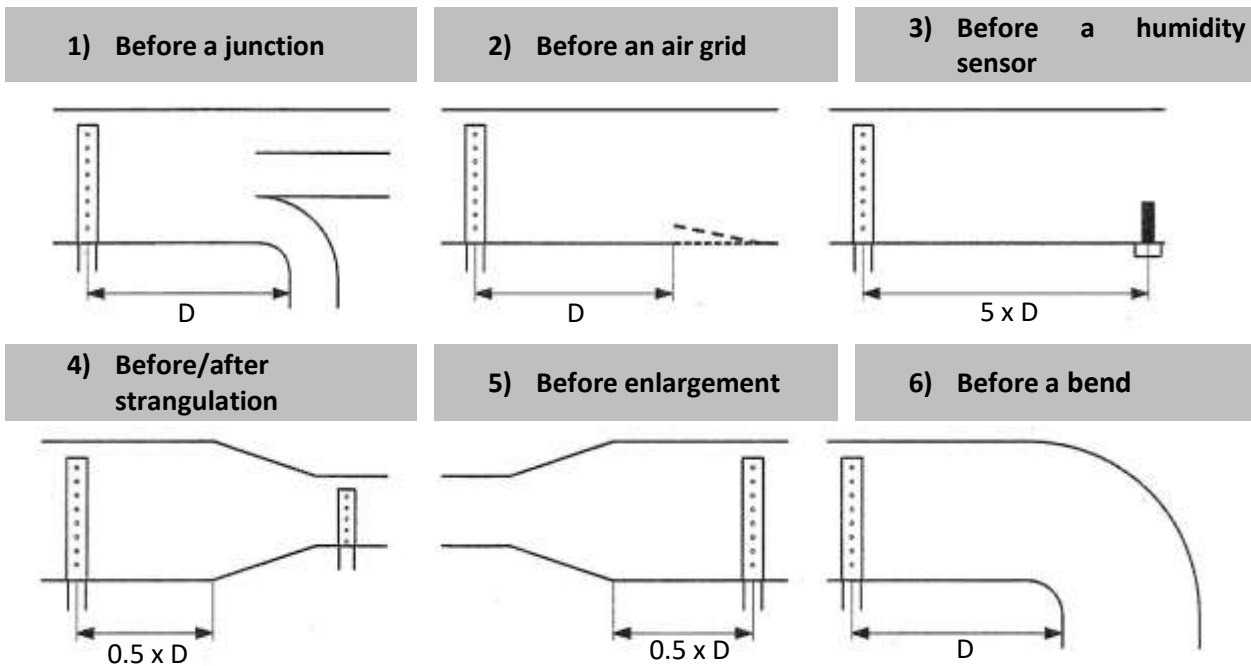


Fig. D 3-3. Installation distances

- A high limit humidistat must be installed in the duct to stop the humidifier in case the level of humidity exceeds the preset value.
- If the recommended distances cannot be met, please contact Devatec or their authorized agent for an alternative solution.
- Make sure the distances are met, if this is not possible, please contact your Devatec agent.

# ELECTROVAP® ELMC

Make sure that spaces and distances are respected. If you have any doubts about the calculation, please contact us.

H1 = 110 mm = Minimum height between the duct floor and the axle of the steam pipe.

H2 = 140 mm minimum for a standard mounting / 110 mm minimum for a stair mounting.

H3 = 160 mm = Minimum height between the axle of the dispersion tube and the top of the duct wall.

The H3 distance can be 80 mm at the shortest if the steam pipe is installed at a 30° angle.

In the case of a stair mounting, minimum distance between tubes = 100 mm.



Air flow direction

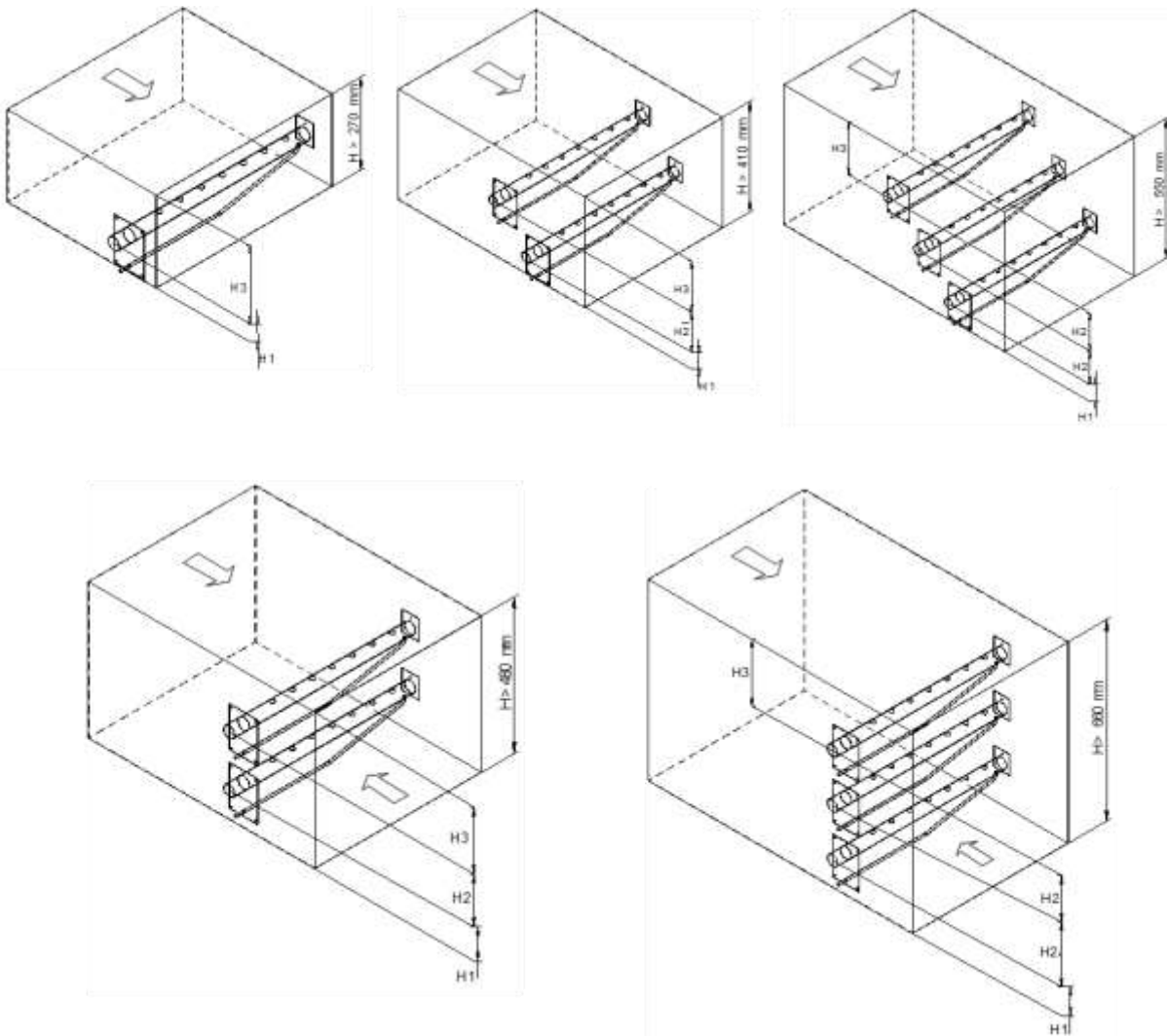
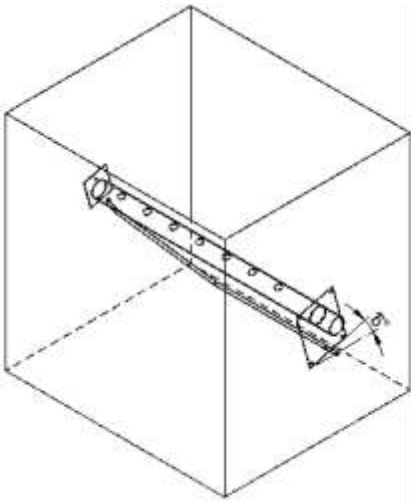


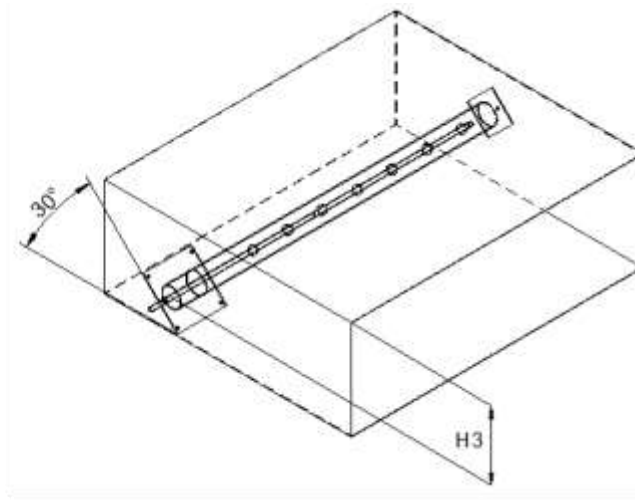
Fig. E 3-3. Minimum heights & flow directions

# ELECTROVAP® ELMC



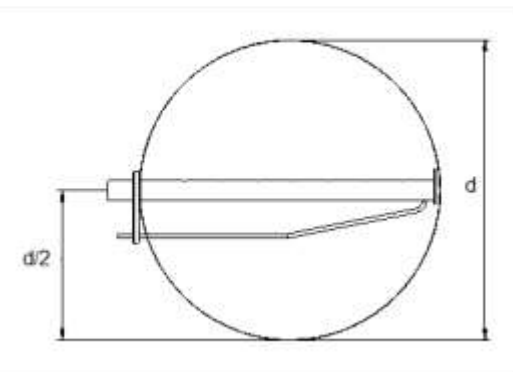
**Fig. F 3-3. Vertical ducts**

In vertical ducts where the air flow is upward or downward, the steam distribution pipe(s) must be tilted by 15° sideways

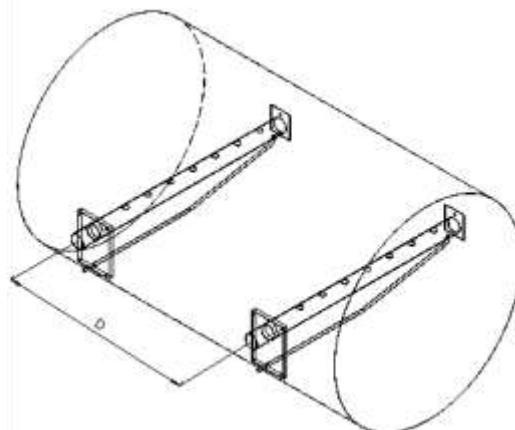


**Fig. G 3-3. Ducts with limited height**

In ducts with limited height, the distribution pipe(s) can be tilted by 30° to get the 80 mm. minimum height



**Fig. H 3-3.  $d$  = Diameter of the duct**



**Fig. I 3-3.  $D$  = Distance between two tubes**



# ELECTROVAP® ELMC

## 3.4 STEAM OUTLET

1. Preferably use a flexible steam hose that is resistant to a temperature of 100°C.

NB: when new hoses are installed, a smell of burnt plastic may be smelt during the first running of the steam humidifier. This is normal and will eventually diminish.

2. Steam hose selection:

Model	ELMC 5 to 15	ELMC 20 to 30	ELMC 40 to 60	ELMC 90
Number of steam outputs	1	1	2	3
Diameter steam output hose [mm]	Ø 25-40	Ø 40 or 25	Ø 40 or 25	Ø 40 or 25

3. ELMC humidifiers can operate with a pressure (P) higher than the atmospheric pressure in the ducts, but under the following conditions:

- If P is less than 150 mm WC or 1470 Pa.
- If P is greater than 150 mm WC (1470 Pa), options are available up to 700 mm WC (6860 Pa).

4. For the installation of the steam hose, depending on your environment, please respect the recommendations below and use the appropriate tangential hose clamps.

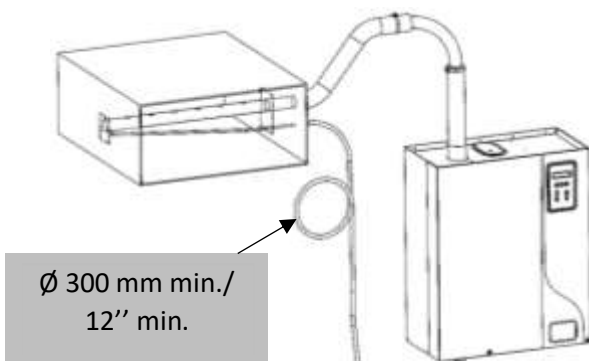
- Flexible steam hose length 3 m max.
- Stainless steel or copper pipe with a slightly larger diameter, grounded. Use a flexible steam hose cuff to connect the humidifier to the steam distribution pipe. The length of the pipe must be thermally insulated and should not exceed 6 m.



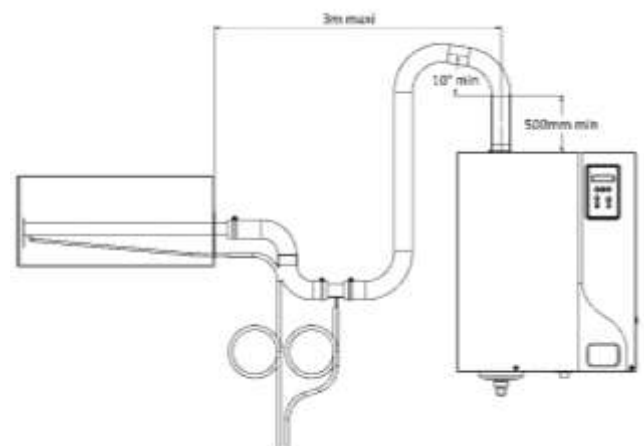
**Always have a slope in the same direction (up or down); the steam hose must be free of kinks and sags to allow for gravity drainage of condensate. Make sure that the steam hose is not leaky. Failure to follow these instructions can lead to serious malfunctions.**

**Radius of the diameter steam pipe:**

- Ø 25 – 250 mm minimum
- Ø 40 – 400 mm minimum



**Fig. A 3-4. Standard installation**



**Fig. B 3-4. Additional drip leg when steam distribution below humidifier**

## 3.5 CONDENSATE DRAINING WITH SIPHON

POSITIVE PRESSURE SIPHON

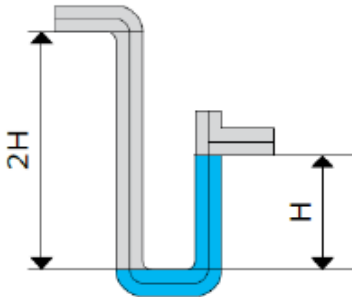


Fig. A 3-5.

NEGATIVE PRESSURE SIPHON

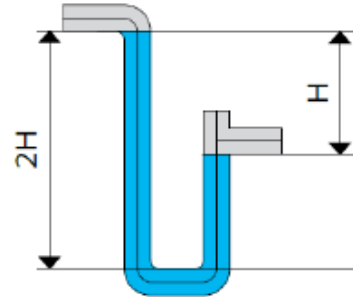


Fig. B 3-5.

The condensate hose must not be directly connected to the public sewerage network.

$$H \text{ min. (mm)} = P \text{ (Pa)} / 10$$

with P = absolute pressure of the air handling unit or the ventilation duct

# ELECTROVAP® ELMC

## 3.6 DRAIN HOSE CONNECTION

The following drawing shows the drain hose connection that should be made.

Use a  $\varnothing$  25 mm rubber drain hose with the 2 supplied hose clamps, heat-resistant (up to 100°C). Connect the hose to the draining system. Regular replacement is recommended.

If rigid piping is used, it must be a heat-resistant PVC material (up to 100 °C).

The discharge hose must be free from any obstacle.

It is recommended that each humidifier has its own drain pipe.

If possible, use a collecting water tank with a lid (see the picture below).

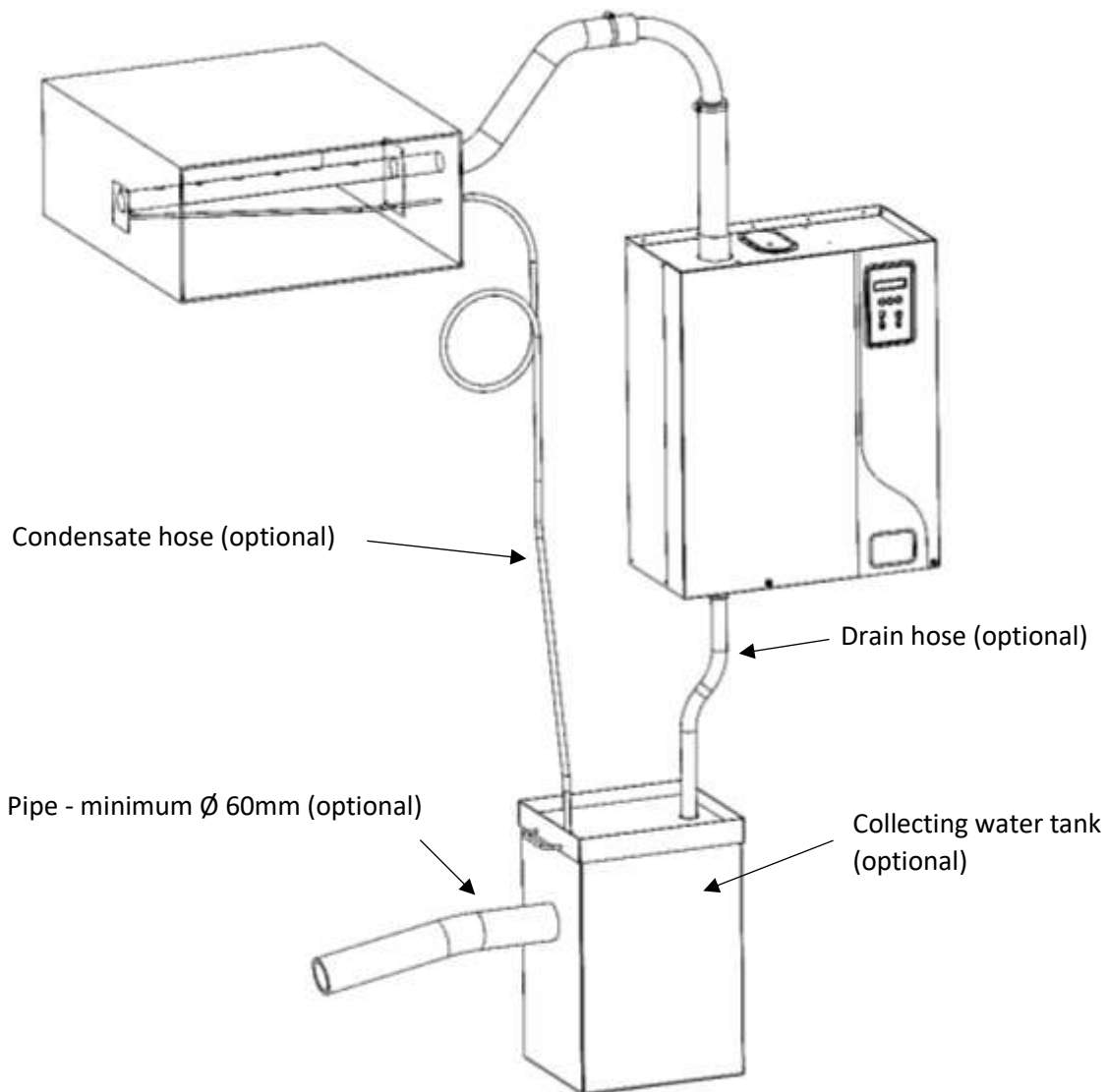


Fig. A 3-6. Example of Installation

# ELECTROVAP® ELMC

A funnel can also be used (see picture below), but it should be offset from the underside of the unit to prevent any steam and/or condensation from getting into the cabinet.

**CAUTION:** keep a minimum downward slope of 10° for both the draining & overflow hoses of the humidifier and for the general drain pipe.

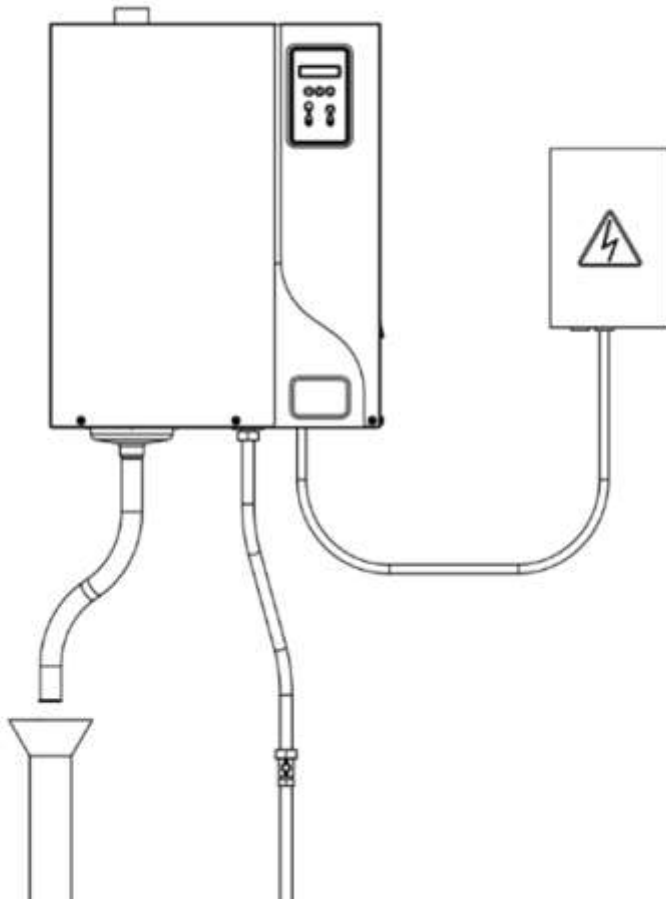


Fig. B 3-6. Example of Installation with funnel

**Note:** ELMC humidifiers are by design equipped with a condensate cooling system that guarantees the following cooling performance:

Model	max T°C in operation <sup>(*)</sup>	max T°C with manual draining <sup>(*)</sup>	max T°C with manual draining after 1hr <sup>(*)</sup>
ELMC 1 SC/1MC	60°C	97°C	70°C
ELMC 2 MC	60°C	97°C	70°C
ELMC 3 MC	60°C	97°C	70°C

<sup>(\*)</sup> measurement made 1m after emptying the humidifier

# ELECTROVAP® ELMC

## 3.7 ELECTRICAL CONNECTIONS

### • Technical data

Supply (V)	ELMC	5	8	10	15	20	30	30HC	40	50	60	60HC	90	90HC
220V - 1 ph	I (A)	18,0		36,1										
	P (kW)	4,0		7,9										
	Prod. (kg/h)	5,0		10,0										
	Cylinder	1 x SC		1 x MC*										
230V - 1 ph	I (A)	17,3		34,6										
	P (kW)	4,0		8,0										
	Prod. (kg/h)	5,0		10,0										
	Cylinder	1 x SC		1 x MC*										
200V - 3ph	I (A)	11,5	18,4	22,9	34,4	45,8	69,7		91,6	114,6	137,3			
	P (kW)	4,0	6,4	8,0	12,0	15,9	24,2		31,9	39,9	47,8			
	Prod. (kg/h)	5,0	8,0	10,0	15,0	20,0	30,4		39,9	50,0	59,9			
	Cylinder	1 x SC	1 x SC	1 x SC	1 x MC*	1 x MC	2 x MC		2 x MC	3 x MC	3 x MC			
208V - 3ph	I (A)	11,0	17,5	21,8	32,7	43,7	66,3		87,3	109,5	131,0			
	P (kW)	4,0	6,4	8,0	12,0	16,0	24,2		31,9	40,0	47,9			
	Prod. (kg/h)	5,0	8,0	10,0	15,0	20,0	30,3		40,0	50,1	60,0			
	Cylinder	1 x SC	1 x SC	1 x SC	1 x MC*	1 x MC	2 x MC		2 x MC	3 x MC	3 x MC			
220V - 3ph	I (A)	10,6	16,7	20,8	30,8	41,6	69,7		84,4	104,5	126,6			
	P (kW)	4,0	6,4	8,0	11,8	15,9	26,7		32,3	40,0	48,5			
	Prod. (kg/h)	5,1	8,0	10,0	14,8	19,9	33,4		40,5	50,1	60,7			
	Cylinder	1 x SC	1 x SC	1 x SC	1 x MC*	1 x MC	2 x MC		2 x MC	3 x MC	3 x MC			
230V - 3ph	I (A)	10,1	16,2	20,2	30,2	40,3	66,3		80,6	100,7	120,9			
	P (kW)	4,1	6,5	8,1	12,1	16,1	26,5		32,3	40,3	48,4			
	Prod. (kg/h)	5,1	8,1	10,1	15,1	20,2	33,2		40,4	50,5	60,6			
	Cylinder	1 x SC	1 x SC	1 x SC	1 x MC*	1 x MC	2 x MC		2 x MC	3 x MC	3 x MC			
380V - 3ph	I (A)	6,3	9,6	12,0	18,0	24,0	36,1	38,2	48,1	60,4	72,6	76,4	110,8	114,6
	P (kW)	4,2	6,4	8,0	11,9	15,9	23,9	25,3	31,8	39,9	48,0	50,5	73,3	75,8
	Prod. (kg/h)	5,2	8,1	10,0	14,9	19,9	29,9	31,6	39,9	50,0	60,1	63,3	91,8	94,9
	Cylinder	1 x SC	1 x SC	1 x SC	1 x SC	1 x MC	1 x MC	1 x MC	2 x MC	2 x MC	2 x MC	2 x MC	3 x MC	3 x MC
400V - 3ph	I (A)	5,8	9,3	11,6	17,4	23,2	34,8	37,6	46,4	57,9	69,7	75,1	104,5	112,7
	P (kW)	4,0	6,5	8,1	12,1	16,2	24,2	26,1	32,3	40,3	48,5	52,3	72,7	78,4
	Prod. (kg/h)	5,1	8,1	10,1	15,2	20,2	30,4	32,8	40,5	50,4	60,7	65,5	91,1	98,3
	Cylinder	1 x SC	1 x SC	1 x SC	1 x SC	1 x MC	1 x MC	1 x MC	2 x MC	2 x MC	2 x MC	2 x MC	3 x MC	3 x MC
420V - 3ph	I (A)	5,6	9,0	11,2	16,8	22,4	33,6	36,3	44,7	56,2	67,1	72,6	100,7	108,9
	P (kW)	4,1	6,6	8,2	12,3	16,3	24,5	26,5	32,7	41,1	49,1	53,1	73,6	79,6
	Prod. (kg/h)	5,1	8,2	10,2	15,4	20,5	30,7	33,2	41,0	51,4	61,4	66,5	92,2	99,7
	Cylinder	1 x SC	1 x SC	1 x SC	1 x SC	1 x MC	1 x MC	1 x MC	2 x MC	2 x MC	2 x MC	2 x MC	3 x MC	3 x MC
440V - 3ph	I (A)	5,3	8,5	10,6	15,8	21,1	31,7	34,0	42,2	52,8	63,3	68,0	95,0	102,0
	P (kW)	4,0	6,5	8,1	12,1	16,2	24,2	26,0	32,3	40,4	48,5	52,0	72,7	78,1
	Prod. (kg/h)	5,1	8,1	10,1	15,2	20,2	30,4	33,6	40,5	50,6	60,7	65,2	91,1	97,8
	Cylinder	1 x SC	1 x SC	1 x SC	1 x SC	1 x MC	1 x MC	1 x MC	2 x MC	2 x MC	2 x MC	2 x MC	3 x MC	3 x MC
460V - 3ph	I (A)	5,1	8,0	10,1	15,1	20,2	30,4	32,7	40,3	50,7	60,8	65,4	91,2	98,2
	P (kW)	4,1	6,4	8,1	12,1	16,1	24,3	26,2	32,3	40,6	48,7	52,4	73,0	78,6
	Prod. (kg/h)	5,1	8,0	10,2	15,1	20,2	30,5	32,8	40,4	50,8	60,9	65,6	91,4	98,4
	Cylinder	1 x SC	1 x SC	1 x SC	1 x SC	1 x MC	1 x MC	1 x MC	2 x MC	2 x MC	2 x MC	2 x MC	3 x MC	3 x MC
480V - 3ph	I (A)	4,9	7,7	9,7	14,5	19,3	29,1	31,5	38,6	48,6	57,9	62,9	87,4	94,4
	P (kW)	4,1	6,5	8,1	12,1	16,1	24,3	26,3	32,3	40,6	48,3	52,5	73,0	78,8
	Prod. (kg/h)	5,1	8,1	10,2	15,1	20,2	30,5	32,9	40,4	50,8	60,5	65,8	91,4	98,7
	Cylinder	1 x SC	1 x SC	1 x SC	1 x SC	1 x MC	1 x MC	1 x MC	2 x MC	2 x MC	2 x MC	2 x MC	3 x MC	3 x MC
575V - 3ph	I (A)	4,0	6,5	8,0	12,1	16,2	24,3	26,4	32,3	40,2	48,6	52,8	72,9	79,2
	P (kW)	4,1	6,5	8,1	12,3	16,3	24,5	26,6	32,6	40,5	49,0	53,3	73,6	79,9
	Prod. (kg/h)	5,1	8,1	10,1	15,3	20,4	30,7	33,4	40,8	50,7	61,4	66,7	92,0	100,0
	Cylinder	1 x SC	1 x SC	1 x SC	1 x SC	1 x MC	1 x MC	1 x MC	2 x MC	2 x MC	2 x MC	2 x MC	3 x MC	3 x MC
600V - 3ph	I (A)	3,9	6,3	7,7	11,6	15,5	23,2	25,4	31,0	38,5	46,5	50,7	69,7	76,1
	P (kW)	4,1	6,5	8,1	12,1	16,2	24,3	26,5	32,4	40,2	48,5	52,9	72,8	79,4
	Prod. (kg/h)	5,1	8,1	10,1	15,2	20,3	30,4	33,1	40,6	50,2	60,7	66,2	91,1	99,4
	Cylinder	1 x SC	1 x SC	1 x SC	1 x SC	1 x MC	1 x MC	1 x MC	2 x MC	2 x MC	2 x MC	2 x MC	3 x MC	3 x MC
690V - 3ph	I (A)	3,4	5,4	6,8	10,1	13,4	20,3	22,2	26,8	33,9	40,6	44,4	60,9	66,6
	P (kW)	4,1	6,5	8,1	12,2	16,1	24,4	26,6	32,2	40,6	48,7	53,3	73,1	79,9
	Prod. (kg/h)	5,1	8,1	10,2	15,2	20,2	30,5	33,3	40,3	50,8	60,9	66,7	91,4	100,0
	Cylinder	1 x SC	1 x SC	1 x SC	1 x SC	1 x MC	1 x MC	1 x MC	2 x MC	2 x MC	2 x MC	2 x MC	3 x MC	3 x MC

# ELECTROVAP® ELMC

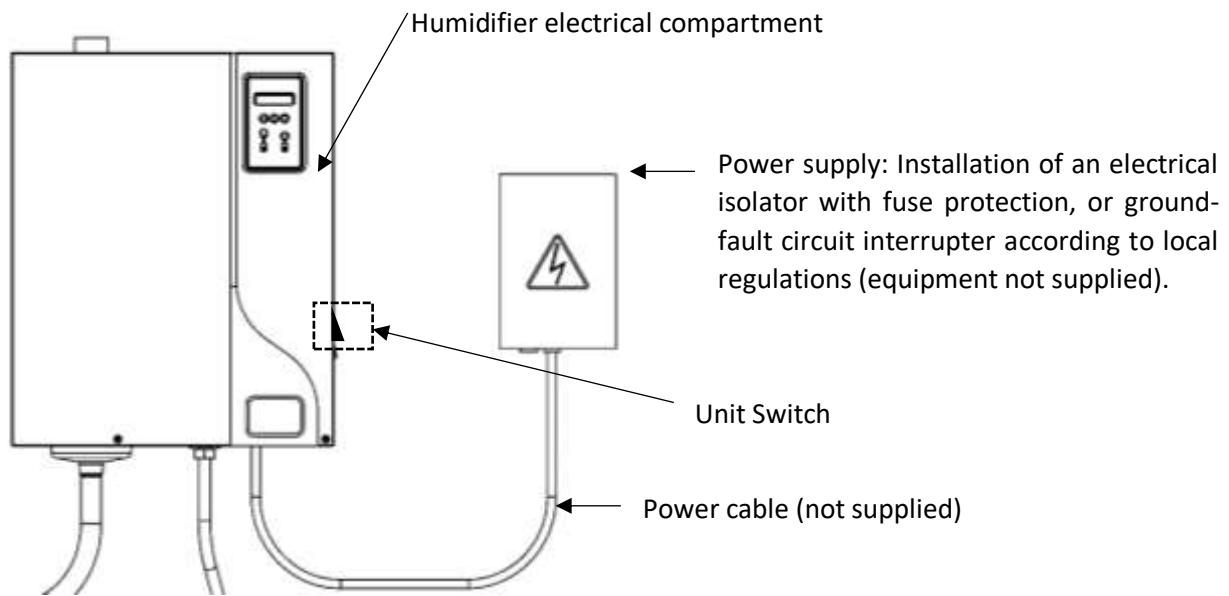


Fig. A 3-7. Electrical connections

	All electrical wiring must enter the unit through a cable gland (not supplied).
	Unit switch: when the unit is switched off, there is still high voltage inside the unit. <b>Electric shock may be fatal, electrical isolator must be switched off.</b>

	<b>All work on the electrical parts must be carried out by qualified and authorized personnel.</b> In addition, before making any electrical connections, check that your installation has been determined from the values in table on page 21. Respect local regulation concerning electrical connections.
	Electronic components are sensitive to electrostatic charges. When working on these components, take appropriate measures to avoid electrostatic discharges.

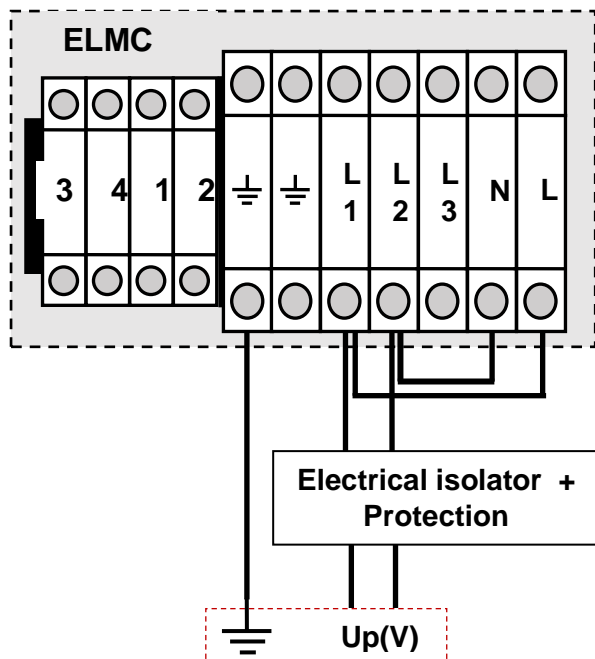
# ELECTROVAP® ELMC

## 3.8 ELECTRICAL WIRING

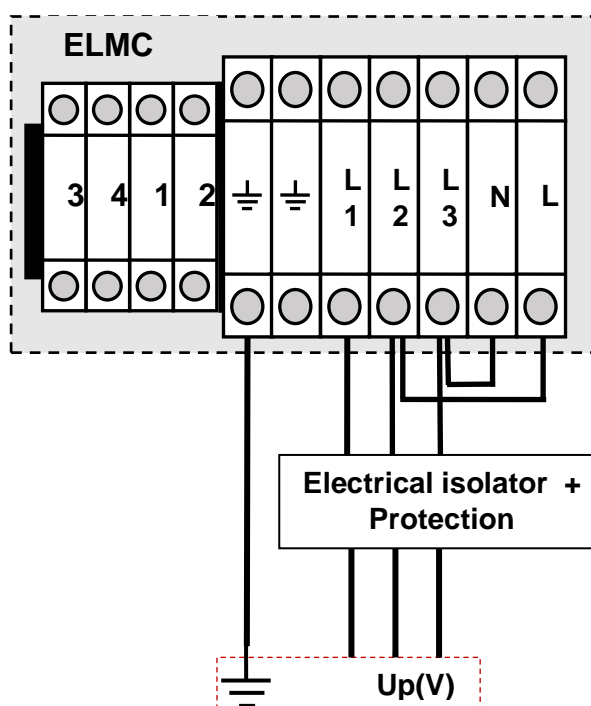
Up [V] = POWER VOLTAGE

Uc [V] = CONTROL VOLTAGE

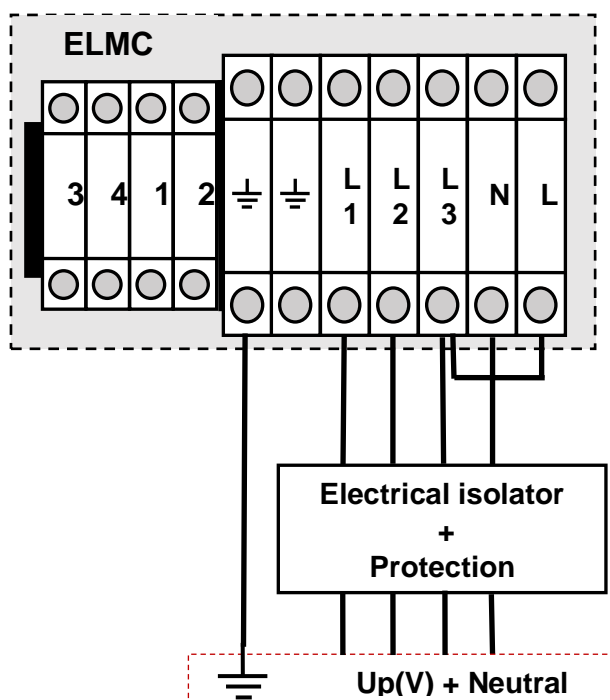
Up(V) = 1x200 - 230Vac (50-60Hz)



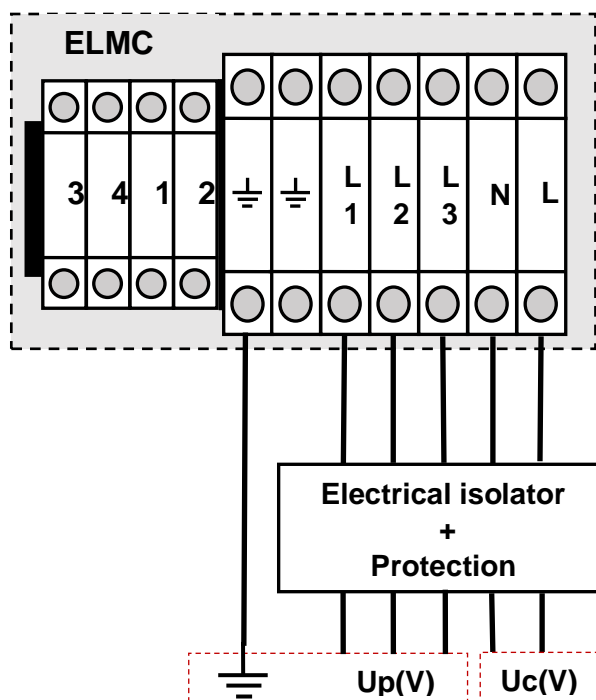
Up(V) = 3x200 - 230Vac (50-60Hz)



Up(V) = 3x380 - 420Vac (50-60Hz)  
with neutral

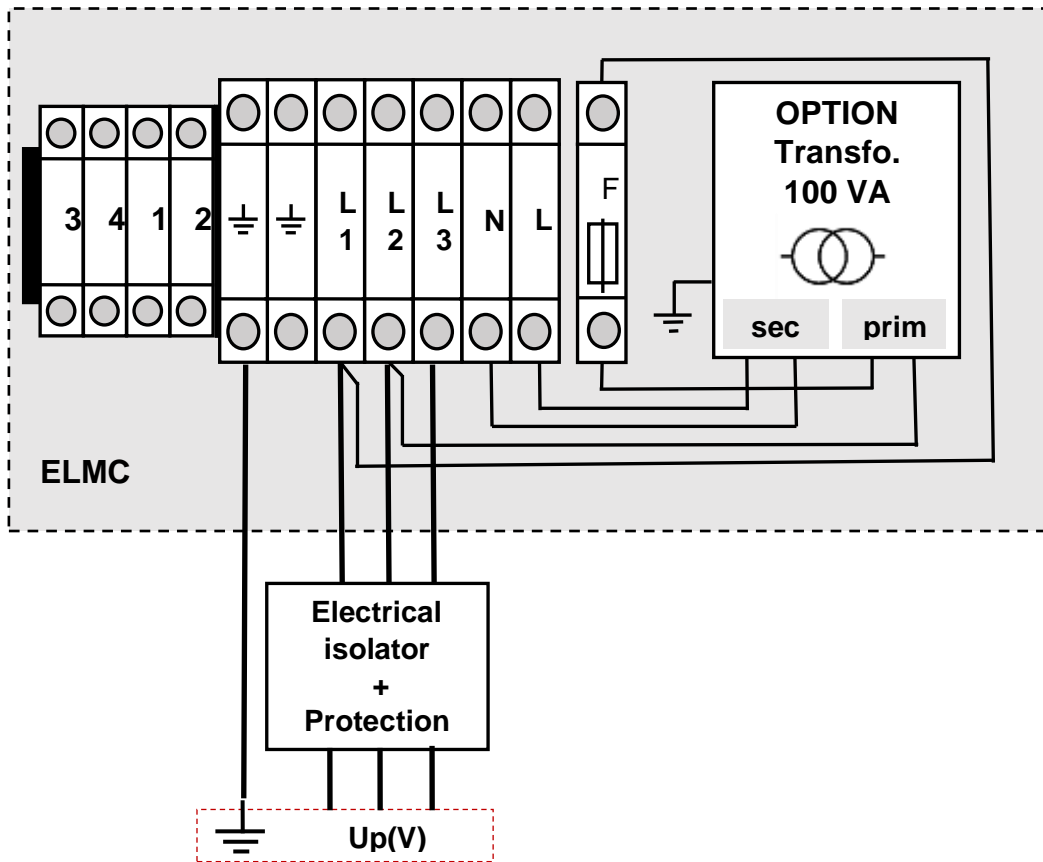


Up(V) = 3x380 - 690Vac (50-60Hz)  
Uc (V) = 1x200 - 230Vac (50-60Hz)



# ELECTROVAP® ELMC

Up(V) = 3x380–690Vac (50-60Hz)  
**OPTION** : Transformer : sec : 2x115V

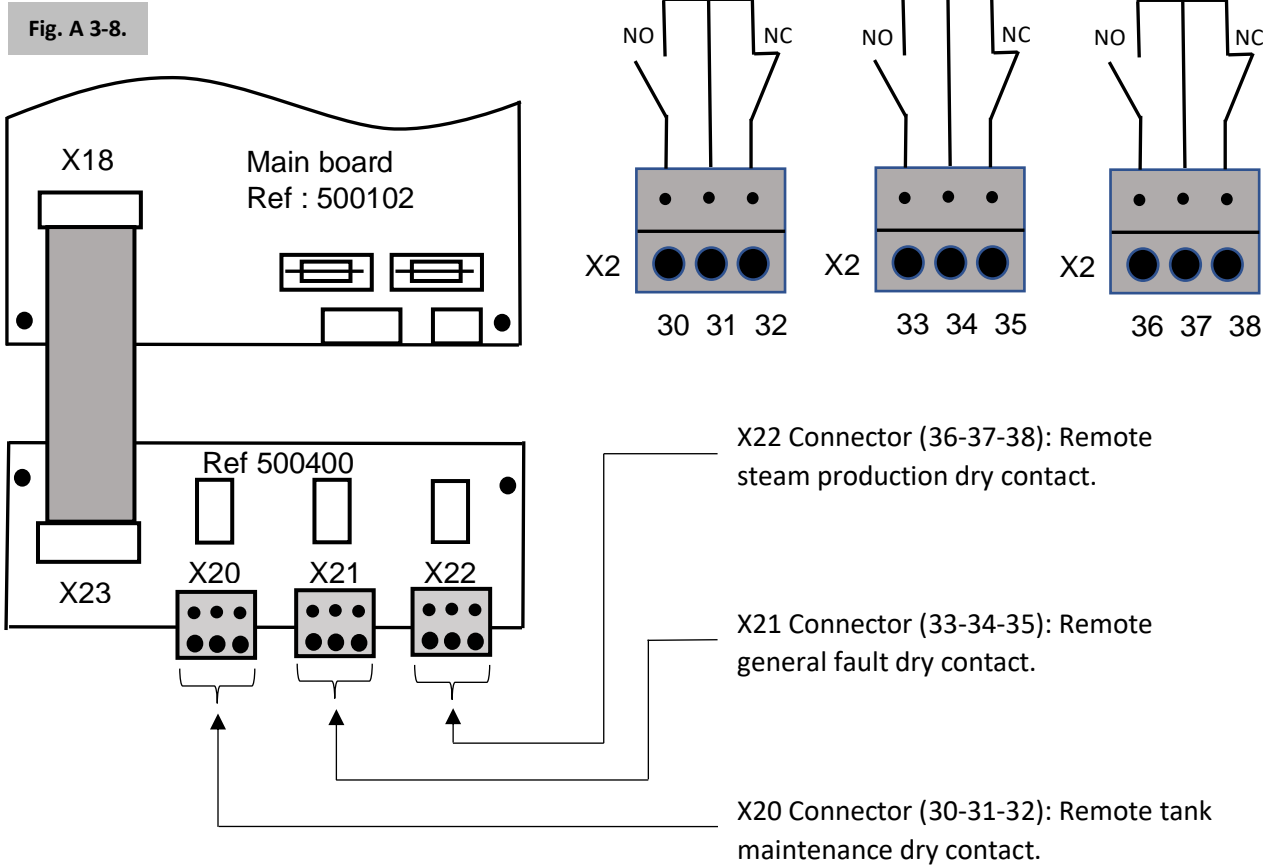




# ELECTROVAP® ELMC

## 3.8.1 Remote information board

The contact can be changed to NO or NC by wiring according to the following diagrams (e.g. wiring on 30 & 31 = NO contact).

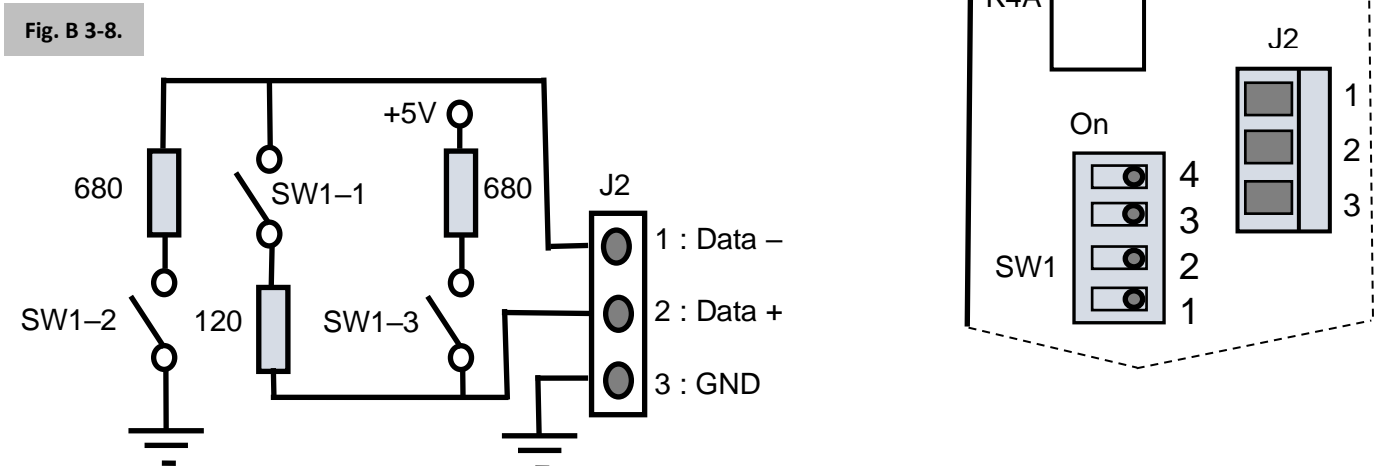


## 3.8.2 RS485 – Hardware connection

RS485 connection must be plugged on the J2 connector:

- Terminal 1: Data -
- Terminal 2: Data +
- Terminal 3: GND

The SW1 switch is used to turn line resistance on or off. Depending on your needs, these resistances can be activated or deactivated (see diagram).



# ELECTROVAP® ELMC

## 3.8.3 MODBUS RTU and BACNET MSTP communication parameters

	Modbus RTU	Bacnet MSTP
Speed of communication	2400 / 4800 / 7200 / 9600 (default) / 14400 / 19200 / 28800 / 38400 / 57600 / 115200 / 230400	
Packet size	8 bits	
Parity Bit	Not	
Stop bit	2	1
Timeout response	5000ms (5sec)	
Time between requests (After a response received)	Min. 100ms	Standard

## 3.8.4 Communication protocol for RS485 interface - MODBUS and BACNET

Modbus Register Address	Bacnet Object Class / instance # / ID (hex)			Description	Value
	Class	Instance #	ID (hex)		
10001	BI	0	00C00000	Contacteur	1 = production -- 0 = no production
10002	BI	1	00C00001	High-level detection	1 = reached-- 0 = no reached
10003	BI	2	00C00002	High limit switch	1 is opened -- 0 is closed
10004	BI	3	00C00003	Fill valve	1 = filling – 0 = no filling
10005	BI	4	00C00004	Drain valve	1 = draining -- 0 : no draining
10006	BI	5	00C00005	relay X10 (term. 3-4): Blower pack / remote ON/OFF, service, default	1 : relay ON -- 0 : relay OFF
10007	BI	6	00C00006	maintenance returns	1 is ON -- 0 is OFF
10008	BI	7	00C00007	Alarm returns	1 is ON -- 0 is OFF
1	BO	0	01000000	On/Off BMS command	1 = ON : Start requested / 0 = Off: Stop Unit
2	Bv	1	01400001	Not used	Not used
3	Bv	2	01400002	option 1 (with SB card 8 relays)	1: ON -- 0: OFF
4	Bv	3	01400003	option 2 (with SB card 8 relays)	1: ON -- 0: OFF
5	Bv	1	01400001	option 3 (with SB card 8 relays)	1: ON -- 0: OFF
6	Bv	2	01400002	option 4 (with SB card 8 relays)	1: ON -- 0: OFF
30001	Have	0	00000000	Type unit	1: Steam Bath, 2: ELMC,3: CMC, 13: EHU 750
30002	Have	1	00000001	Register version	1
30003	Have	2	00000002	Current	10 x (A)

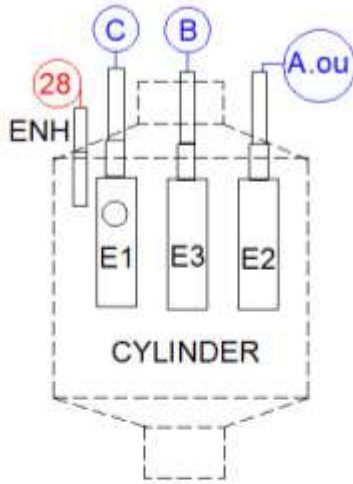
# ELECTROVAP® ELMC

30004	Have	3	00000003	Run status	0: Idle 1: Steam Gen 2: End of season 3: Failure 4: Manual drain 5: Maintenance
30005	Have	4	00000004	maintenance counter	(Hours)
30006	Have	5	00000005	time	(Hours)
30007	Have	6	00000006	time before end-of-season draining	(Hours)
30008	Have	7	00000007	Control Signal value	10 x V or 10 x mA gold %
30009	Have	8	00000008	Temperature (maintenance option or SB)	(C)
30010	Have	9	00000009	Error code	0: Normal operating 1: P1 Error 2: P2 Error 3: P3 Error 4: P4 Error 5: P5 Error 6: P6 Error 7: P7 Error 8: P8 Error 9: P9 Error 10: First inspect. 11: Overdue service
30011	Have	10	0000000A	type of water	1: Tap water 2: Softened water 3: Partial DI water 4: DI water
30012	Have	11	00000000B	type of control	20:On/Off 21: Digital Ctrl 22: Digital Sensor 23: 0-10V CTRL 24:0-5V CTRL 25:0-20mA CTRL 26:0-10V Sensor 27:0-5V Sensor 28:4-20mA Sensor 29: Temp Sensor
30014	Have	13	00000000D	Application	(%)
30015	Have	14	0000000E	steam production	10 x (Kg/hr)
40004	Av	3	00800003	End-of-season (EOS)	(hours) mini - 1 and maxi - 168
40005	Av	4	00800004	Steam capacity limit	(%) mini - 20% and maxi - 100%
40006	Av	5	00800005	RH or demand value (digital or digital probe).	( %) mini - 1 and maxi - 100
40007	Av	6	00800006	RH set point	( %) mini - 1 and maxi - 100SB: (C) 25 to 55
40008	Av	7	00800007	Not used)	Not used
40009	Av	8	00800008	Not used	Not used
40010	Av	9	00800009	maintenance interval	(hours / 100) mini - 1 and maxi - 200
40011	Av	10	0080000A	production adjustment	Draining - 1 or evaporation - 2
40012	Av	11	0080000B	anti-foam drain time	mini - 0 sec and maxi 15 sec

# ELECTROVAP® ELMC

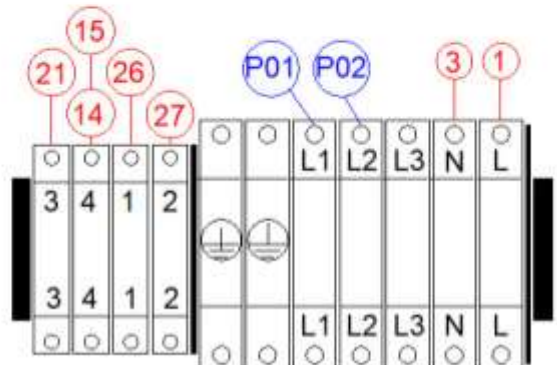
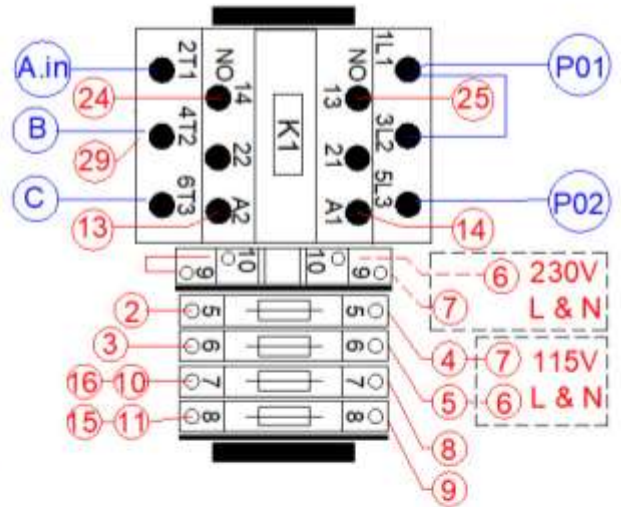
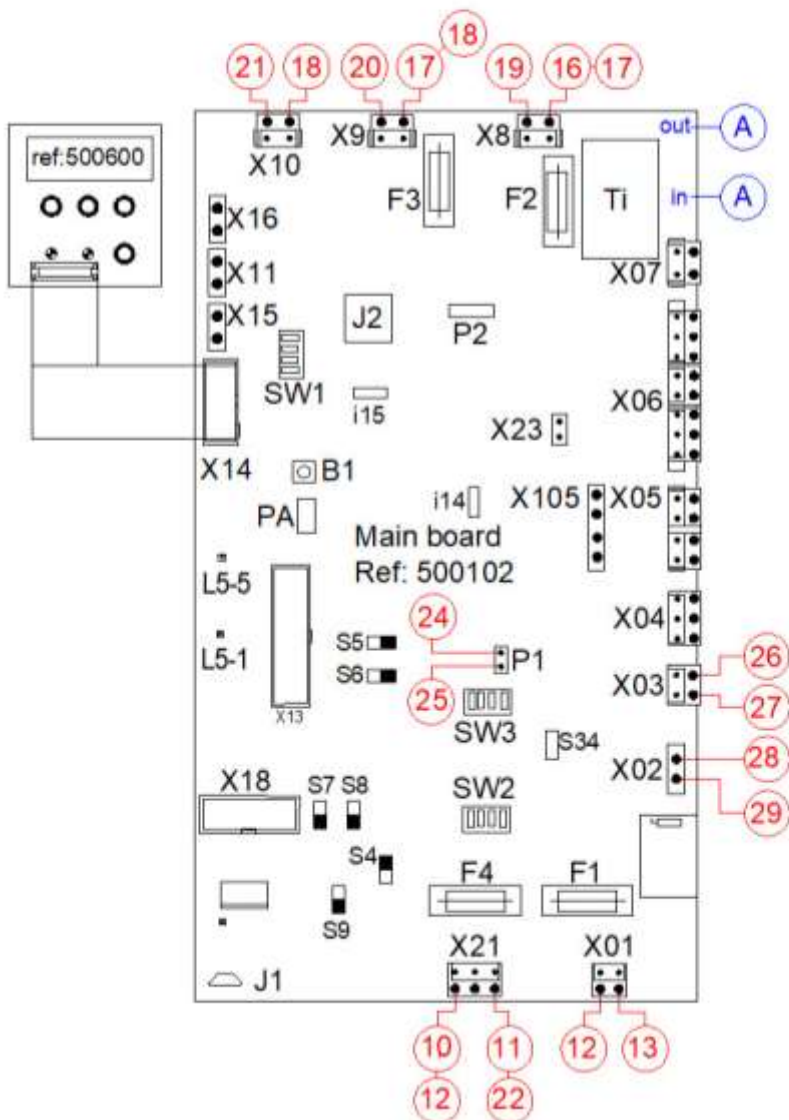
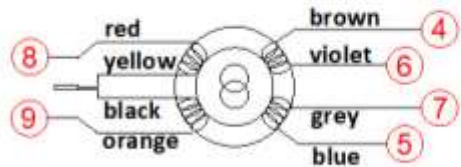
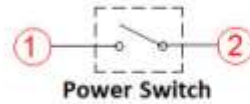
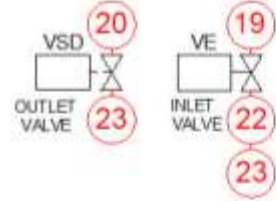
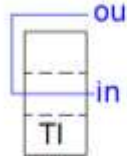
## 3.8.5 Wiring diagrams

ELMC 5 to 10, Up[V] - 1x200-240V 50-60Hz



(C) POWER CABLE WITH COLOR MARK

(A) CABLE THROUGH THE TI



# ELECTROVAP® ELMC

ELMC 5 to 30, Up[V] - 3x200-690V 50-60Hz

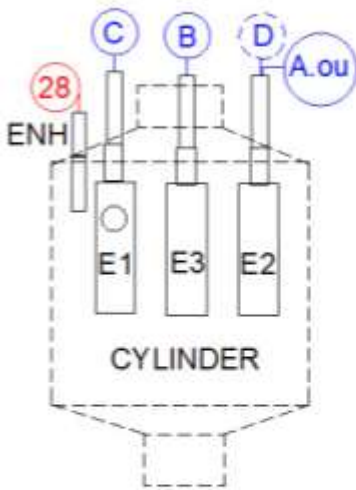
**C** POWER CABLE WITH COLOR MARK

ELMC 15 3x200-240V

**D** DOUBLE WIRE FOR ELMC 20 3x200-240V

ELMC 30 3x380-690V

**A** CABLE THROUGH THE TI



ou ELMC 5 3x200-240V

in ELMC 8 3x200-690V

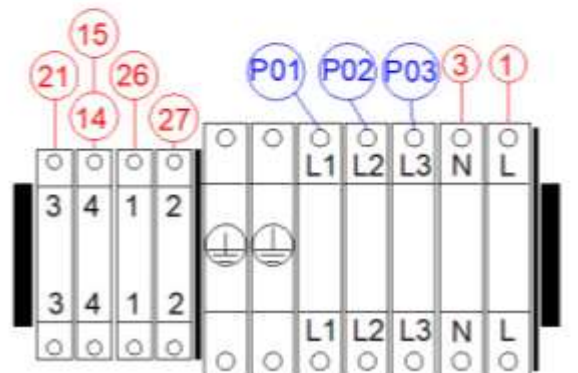
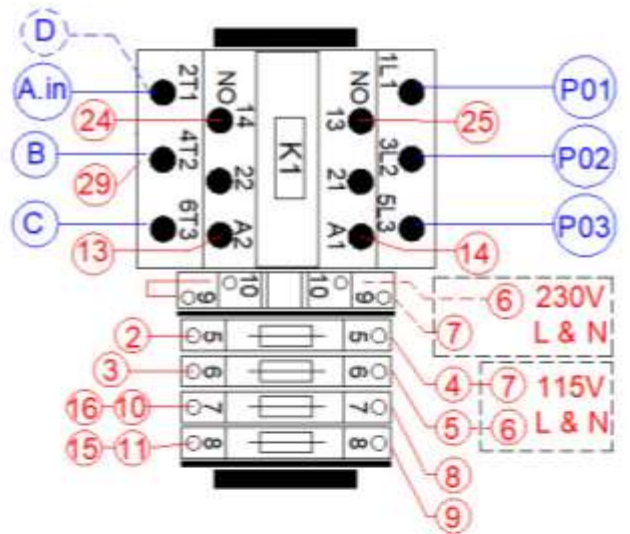
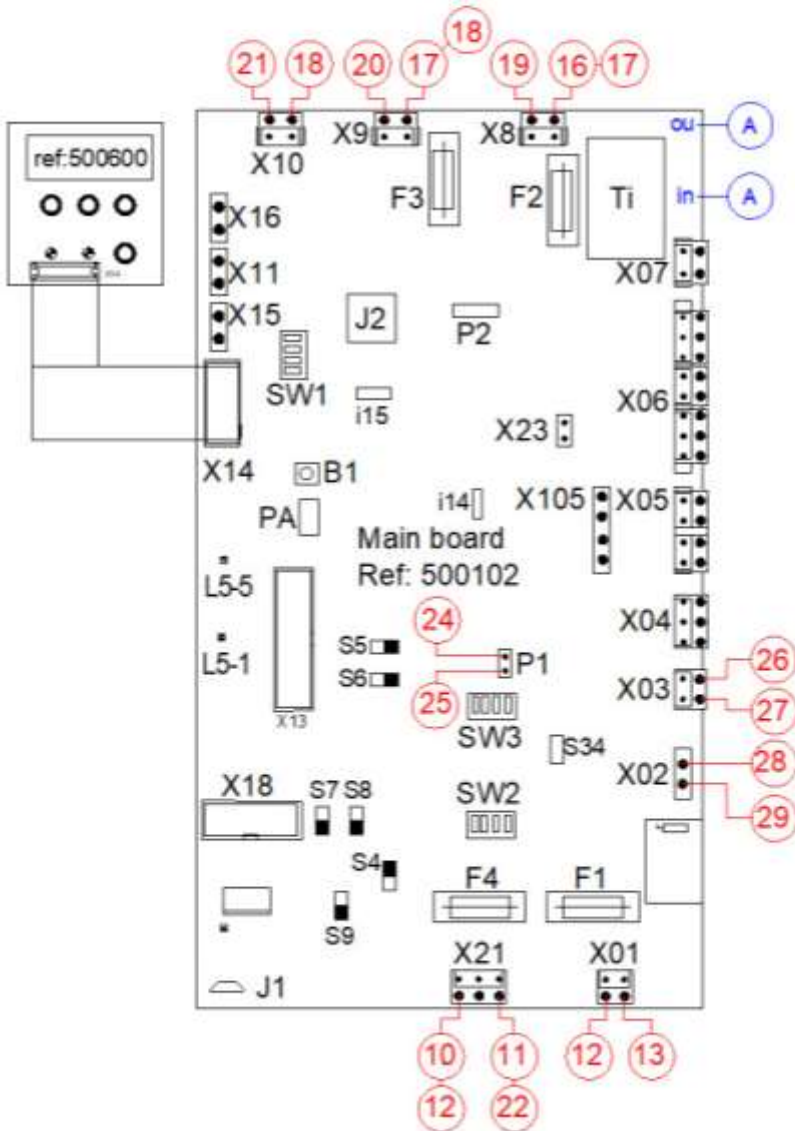
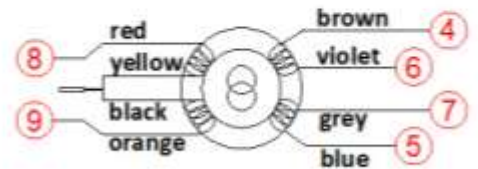
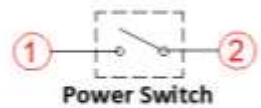
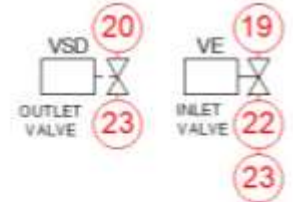
ELMC 10 3x200-690V

ELMC 15 3x380-690V

ELMC 20 3x380-690V

ou ELMC 5 3x380-690V

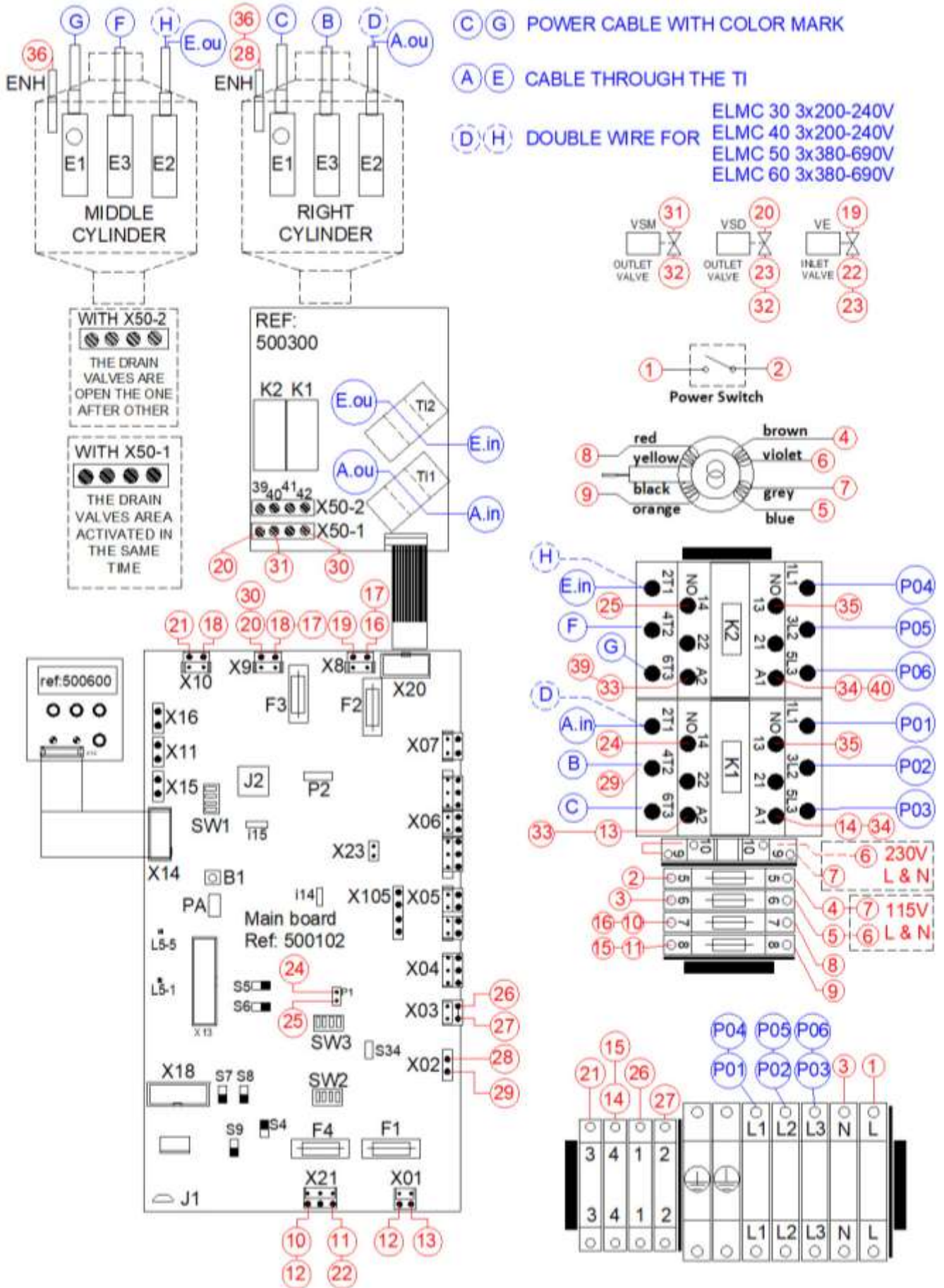
in





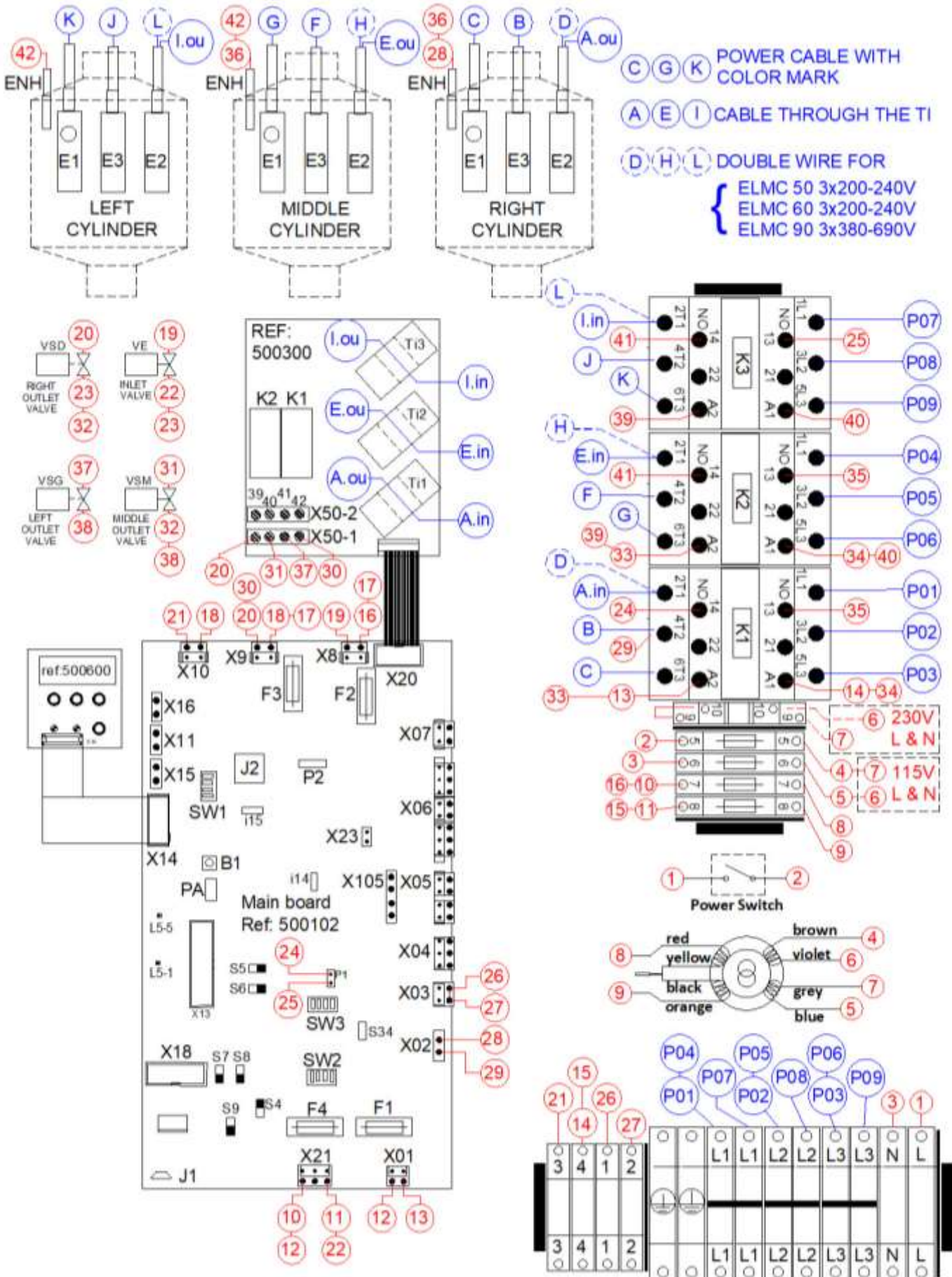
# ELECTROVAP® ELMC

ELMC 40 to 60, Up[V] - 3x200-690V 50-60Hz



# ELECTROVAP® ELMC

ELMC 90, Up[V] - 3x200-690V 50-60Hz

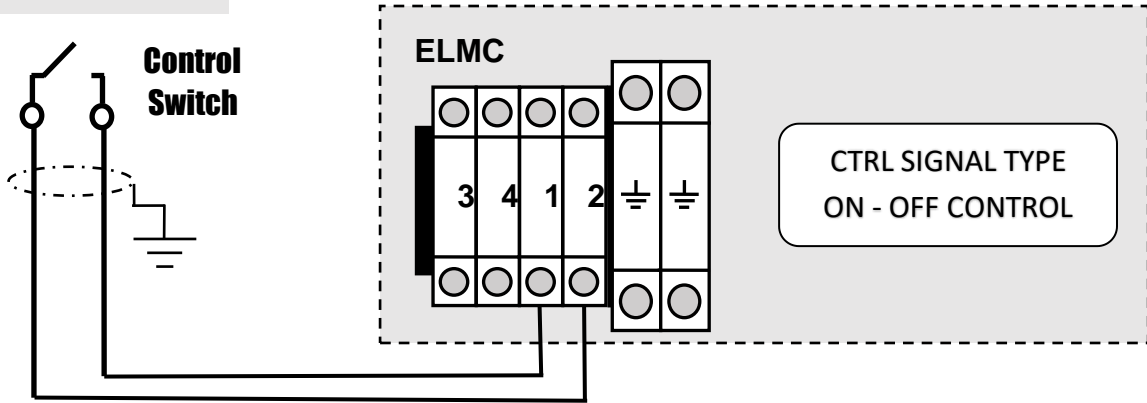


# ELECTROVAP® ELMC

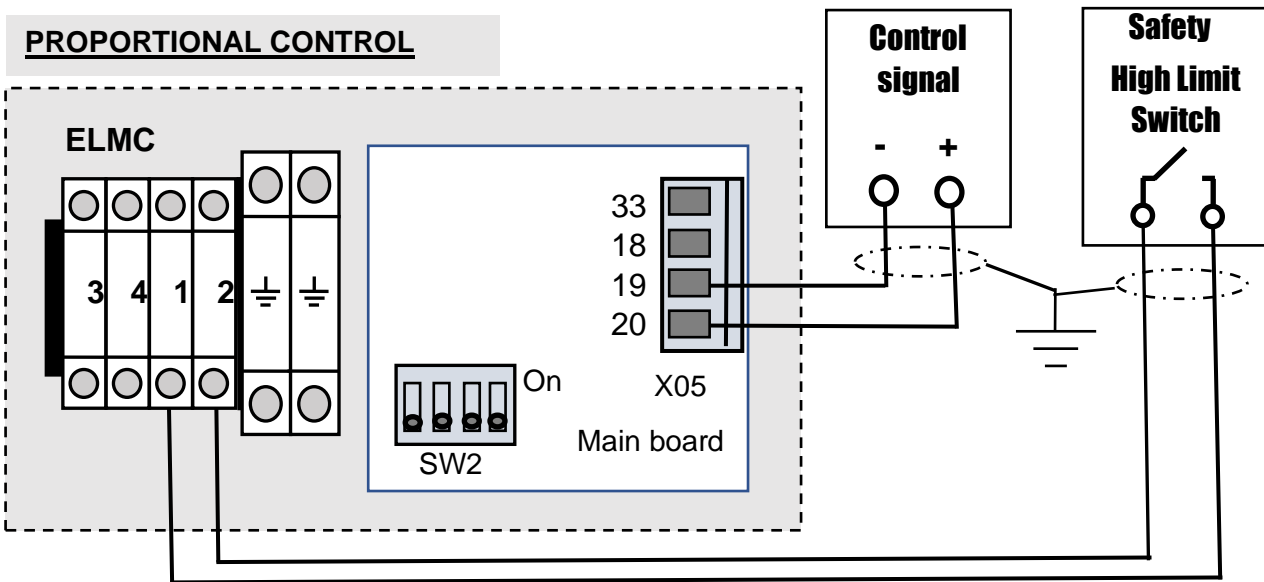
## 3.9 CONTROL SIGNAL CONNECTION

The wiring of the optional equipment must be made with 0.75 mm<sup>2</sup> shielded cable. This control signal wire should not be routed with a power cable.

### ON/OFF CONTROL

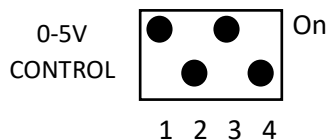
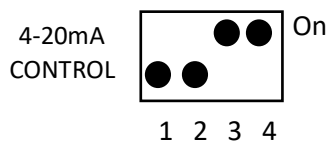
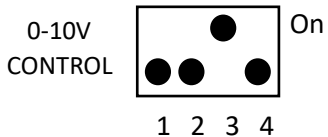


### PROPORTIONAL CONTROL



Control signal type setting in humidifier menu

SW2 Dip switch setting to do on main board



CTRL SIGNAL TYPE

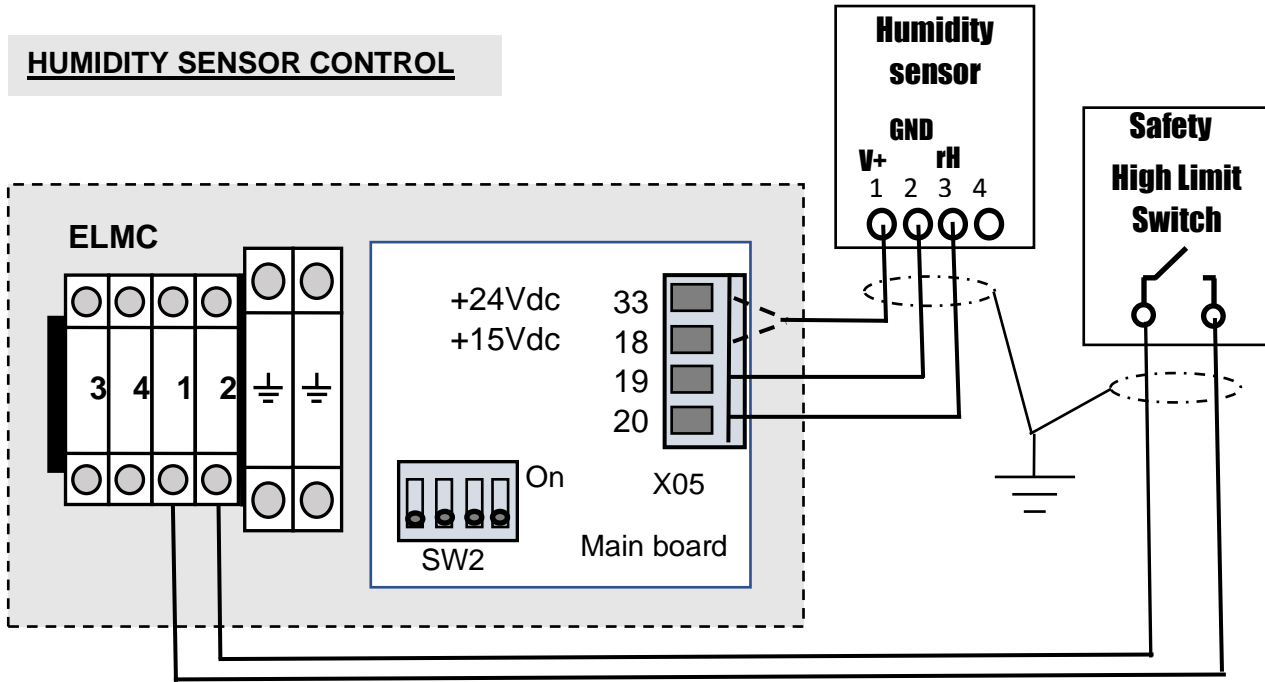
0-10V CONTROL  
4-20mA CONTROL

0 - 5V CONTROL



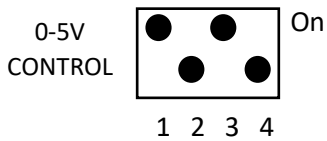
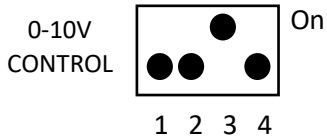
# ELECTROVAP® ELMC

## HUMIDITY SENSOR CONTROL



SW2 Dip switch setting to do on main board

Control signal type setting in humidifier menu



CTRL SIGNAL TYPE

0 - 10V SENSOR

0 - 5V SENSOR

## WITH DIGITAL CONTROL (Modbus - BACnet)

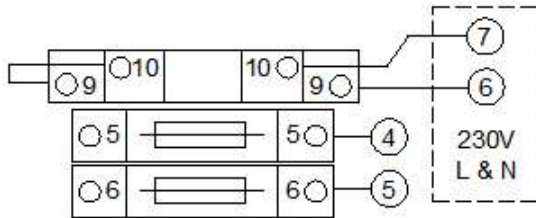
Control signal type setting in humidifier menu

CTRL SIGNAL TYPE  
DIGITAL CONTROL

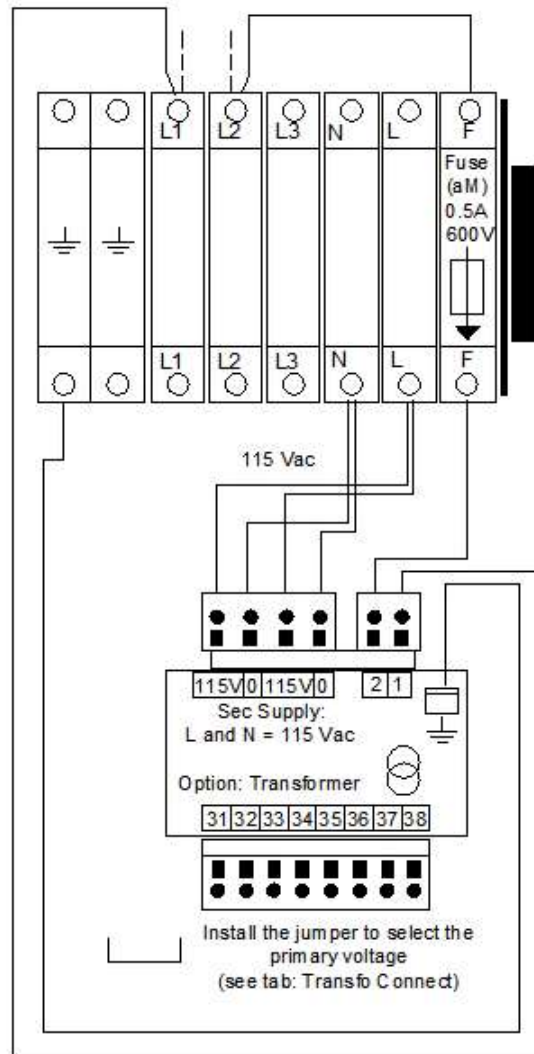
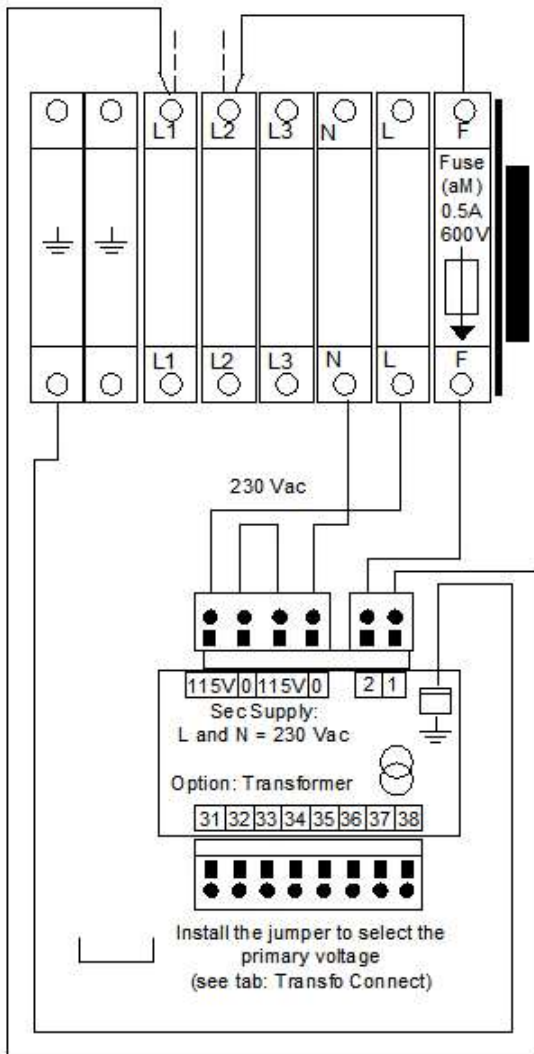
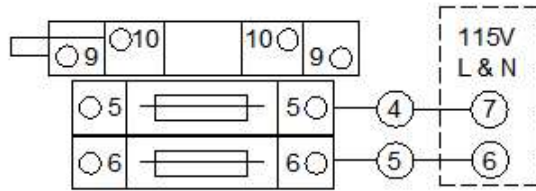
# ELECTROVAP® ELMC

## 3.10 OPTION: Transformer connection

Supply: L and N = 230 Vac



Supply: L and N = 115 Vac



Primary voltage	600V	575V	480V	460V	440V	415V	400V	380V
Jumper position	34-35	33-35	33-36	32-36	32-37	31-37	32-38	31-38

Tab: Transfo Connect

## 4 COMMISSIONING



Before operation, please check that your installation complies with the manufacturer's technical recommendations. Check all power cables electrical connections. Remove the blocking blue foam ring from the tank.

Marker 1: Validation & change menu button

Marker 2: Upward button

Marker 3: Downward button

Marker 4: Manual drain button for maintenance

Marker 5: LED = Steam production indication

- Open the main water supply valve.
- Switch on the main power supply (power and control voltages).
- Switch on the unit switch.
- If the unit asks you for a commissioning code, note the serial number on the nameplate and contact your agent to obtain this code.
- Enter your three-digit code by doing this:  
Press one of the keys 1, 2, 3 and the display will show you 0XX, with the flashing zero to eventually change it by pressing 2 or 3.  
Once arrived at your digit, validate it by pressing key 1 and your second digit flashes. Repeat the previous two operations to show the last two digits.

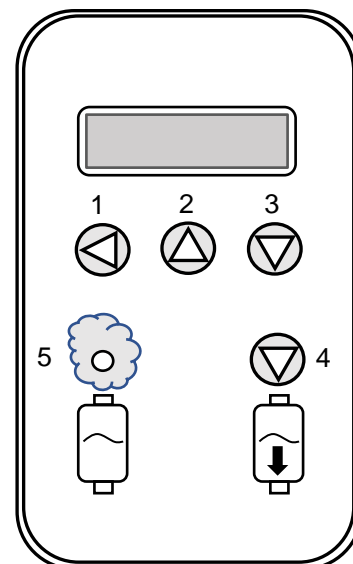


Fig. 4 Humidifier display

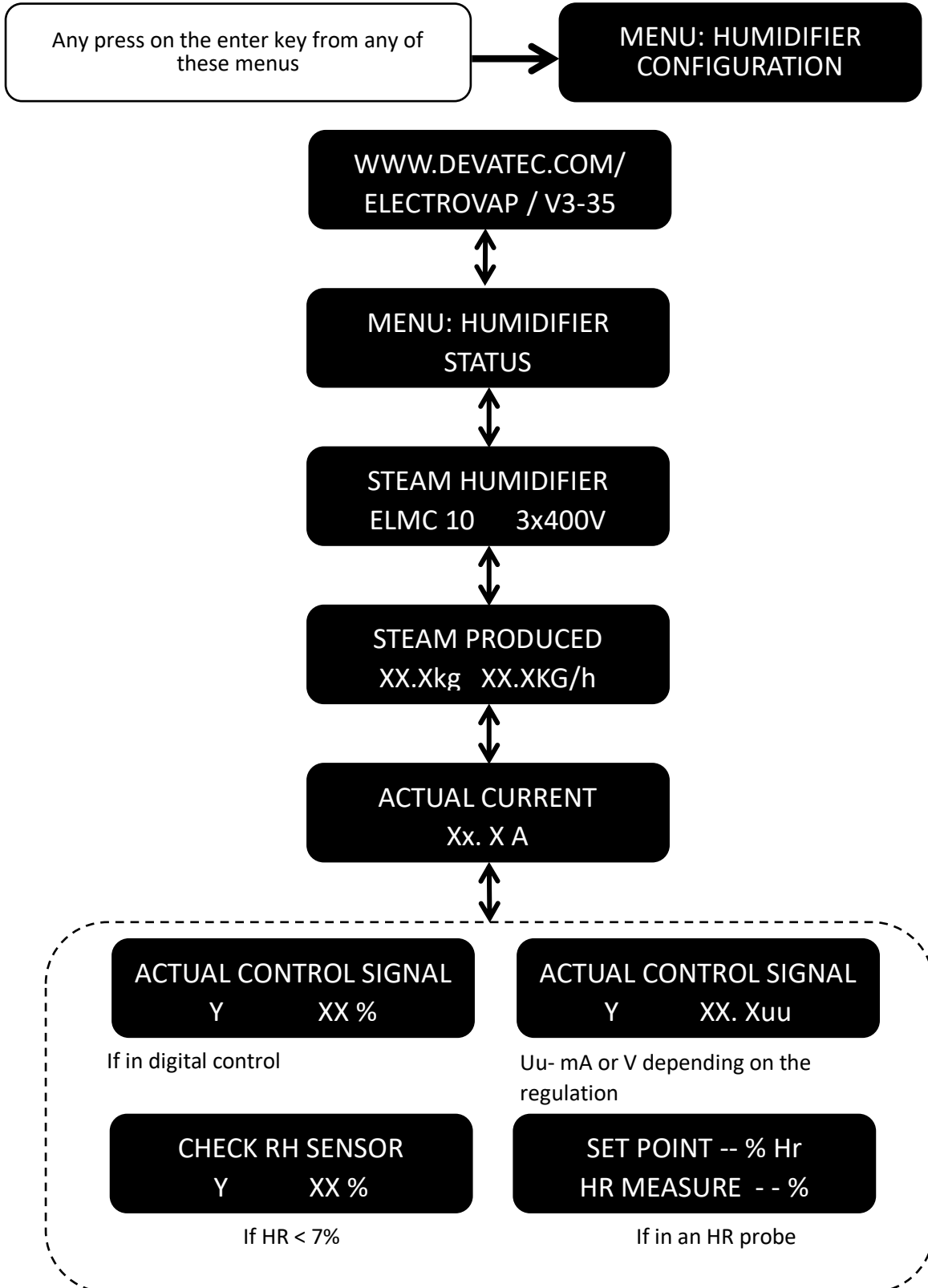
**Very important: do not forget to validate the last digit.**

- Enter water quality in the displayed menu.
- The device is ready to respond any production request.
- During steam production, the LED (5) lights up.

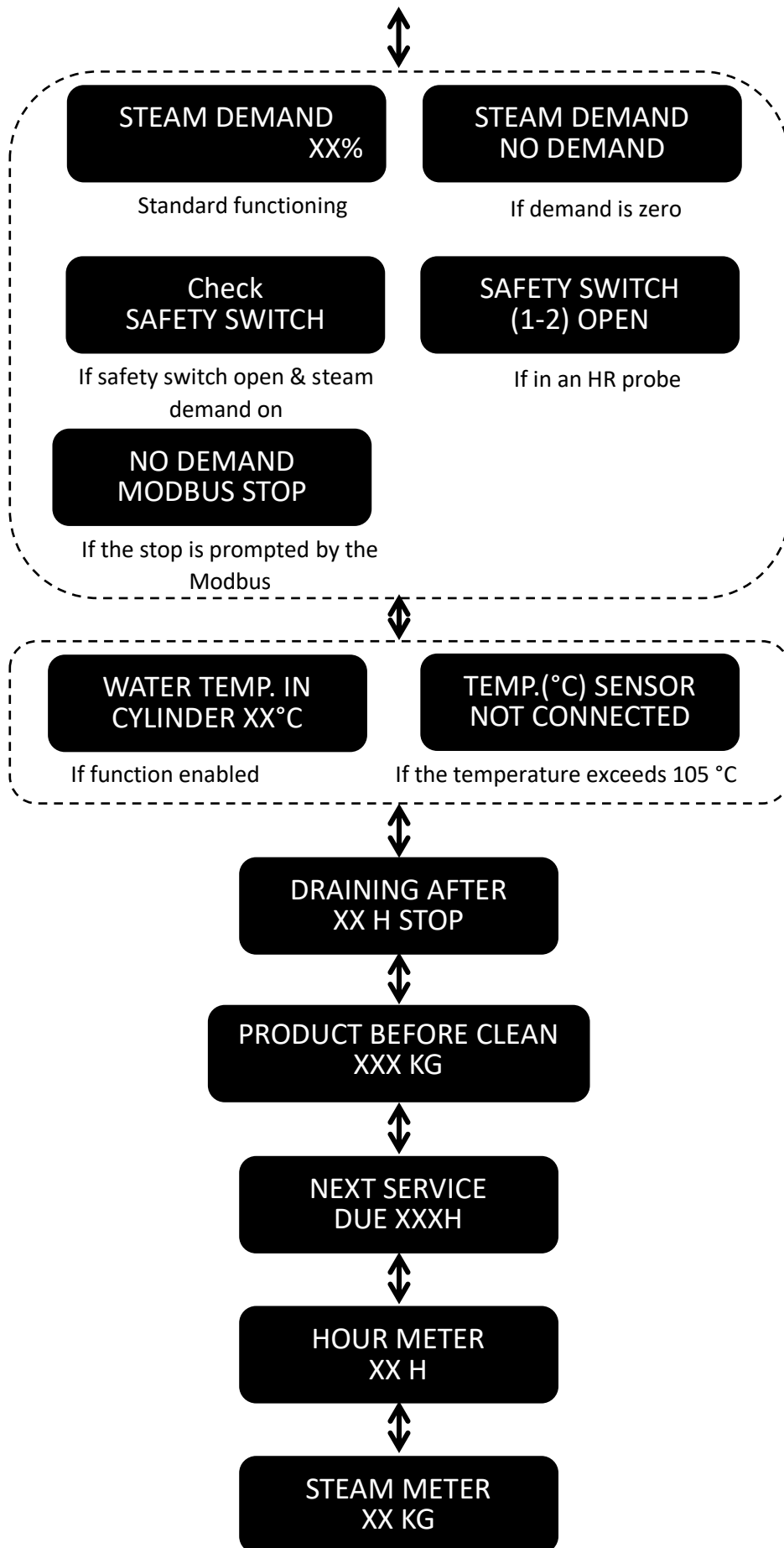
# ELECTROVAP® ELMC

## 5 SYSTEM MANAGEMENT

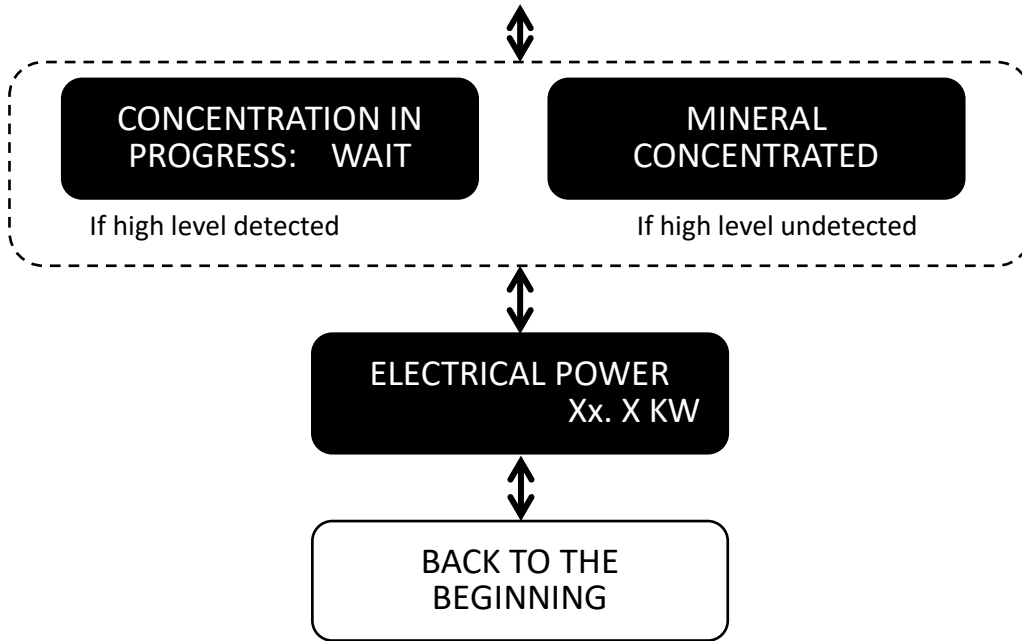
### 5.1 USER INFORMATION MENU (READ ONLY)



# ELECTROVAP® ELMC

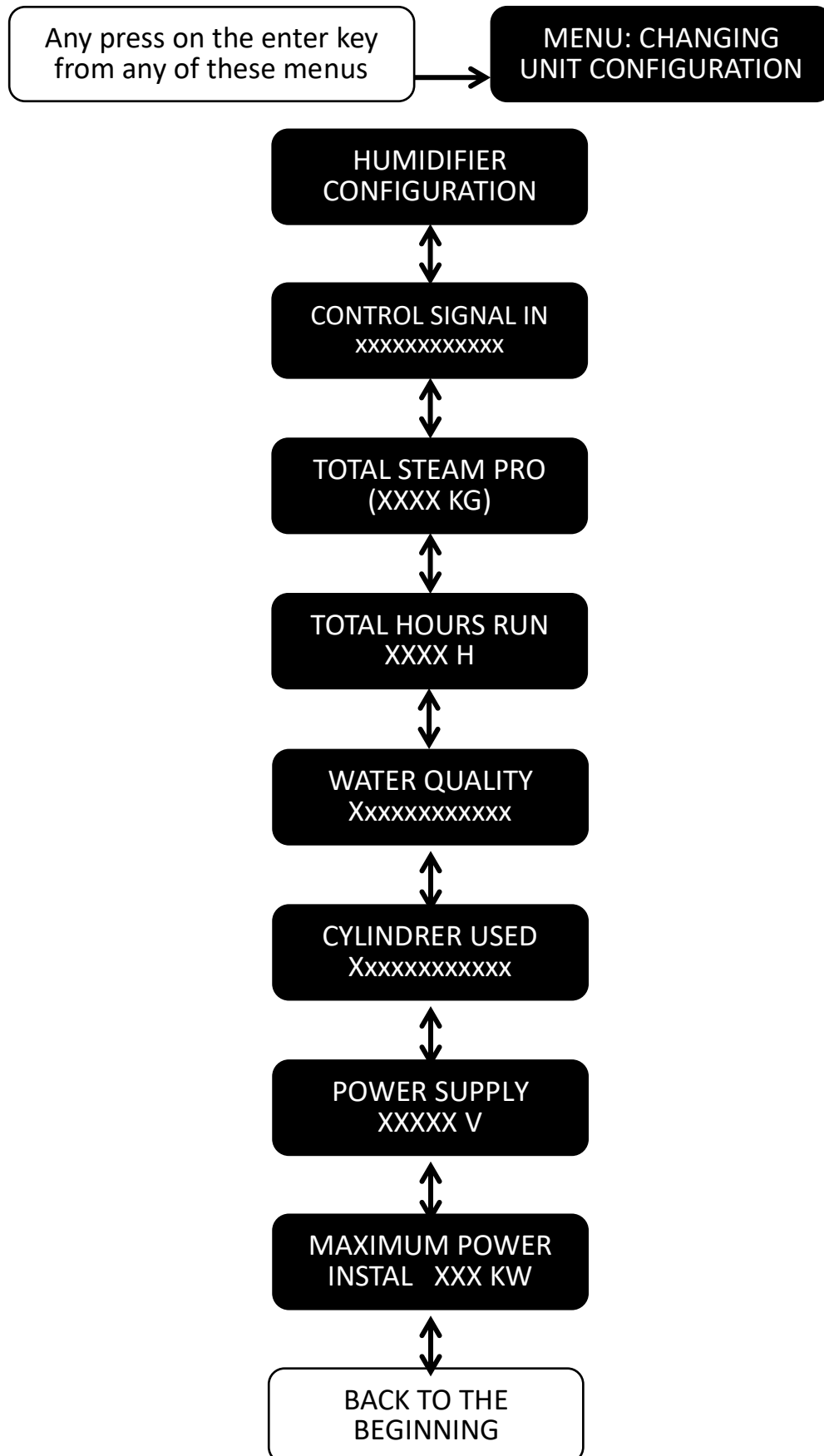


# ELECTROVAP® ELMC

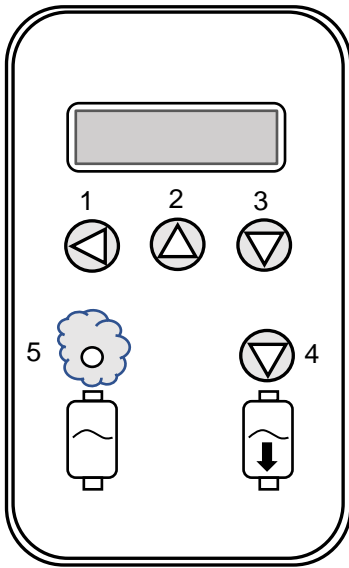


# ELECTROVAP® ELMC

## 5.2 HUMIDIFIER STATUS MENU

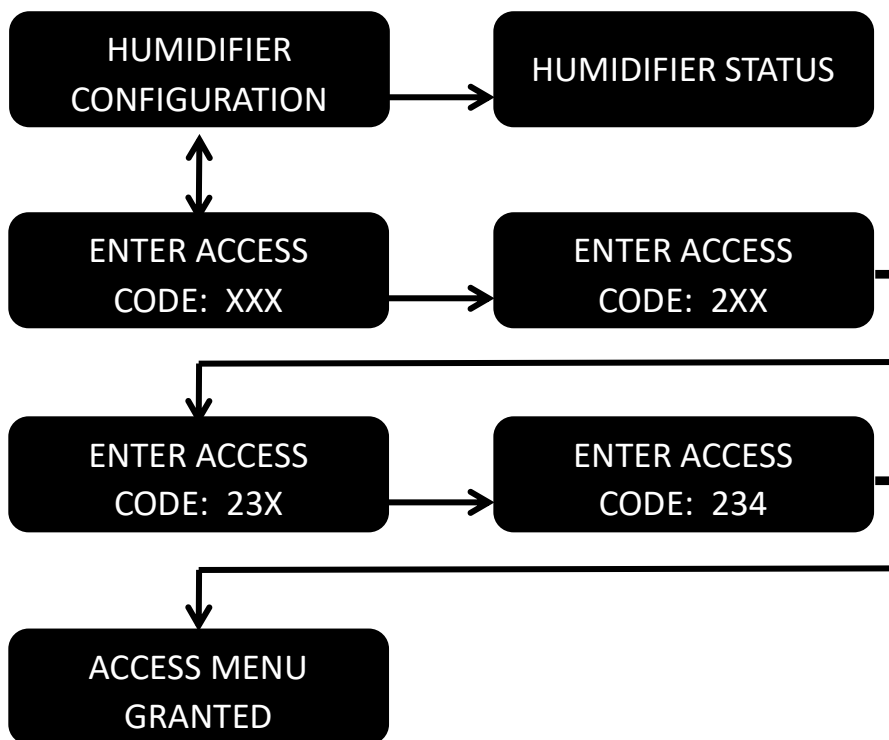


## 5.3 CHANGE SETTINGS MENU



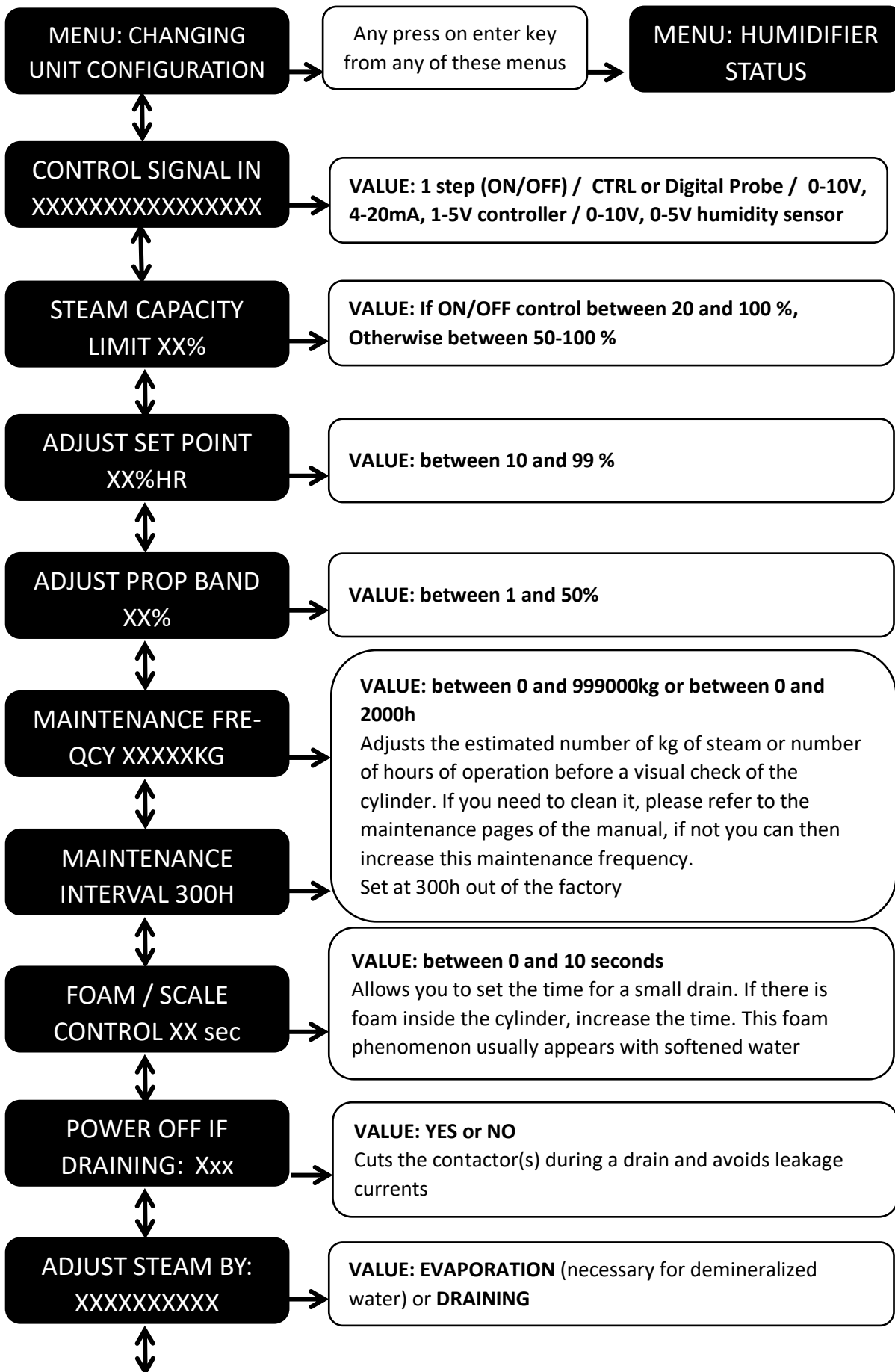
Procedure to enter the access code:

- Press the "1" key: the first cross flashes.
- Press the "2" key to increase the digit or the "3" key to decrease it.
- Once you have reached the desired digit of the code, press the "1" key to validate it: the 2nd cross flashes.
- Proceed in the same way for the following digits, and do not forget to validate the code by pressing the "1" key.

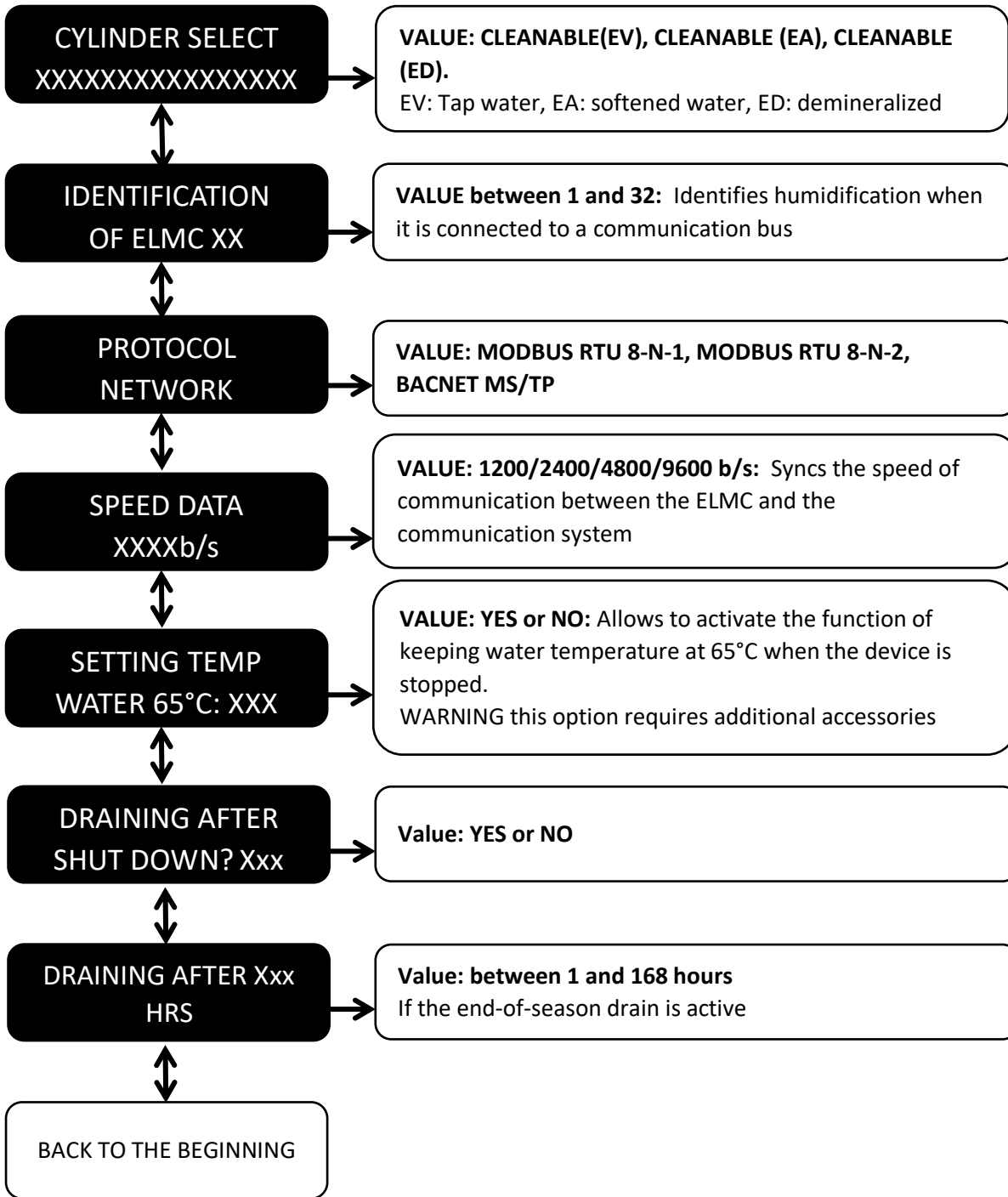




# ELECTROVAP® ELMC



# ELECTROVAP® ELMC



## 5.4 MAINTENANCE ALERTS

### M1: 50 HOURS CONTROL

This message will appear 50 Hrs after the first start. It is then necessary to check the correct tightening of electrical and hydraulic connections (steam pipe, drain system, water supply...). The unit is not stopped

### M2: MAINTENANCE TO DO

The maintenance timer has arrived at 0, it is necessary to do the maintenance of the device. The unit is not stopped

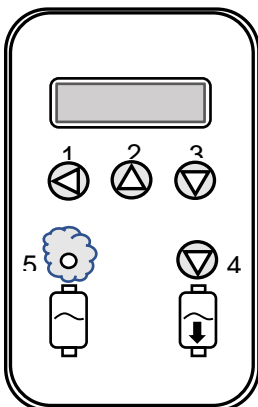
### M3: MAINTENANCE NOT DONE: PURGE

This message appears if 100 hours elapsed between the appearance of the M2 and M3 message and no maintenance has been done. Then the unit is shut down and follows the procedure:

1. Emptying the cylinder
2. Cooling the cylinder
3. Ready for maintenance

### M4: CONTACTOR TO REPLACE

After 10,000 hours of operation, it is recommended to replace the contactor. The unit is not stopped



### TO CARRY OUT A RESET FOR THE ABOVE MESSAGES, FOLLOW THIS PROCEDURE:

- Switch the unit to drain by pressing the manual drain button (4).
- Press button 3 for at least 5 seconds.

## 5.5 DEFAULT MESSAGE



### Meaning:

The signal passing through the contactor is OFF when it should be ON. The contactor no longer works and there is no steam production.

### In this case:

When this message appears, the cylinder is drained, the general fault contact is activated, and the unit is then stopped.

### Causes and remedies:

1. Check the F1 (2A) fuse on the main map.
2. Check the connection of the connector wires of the contactor
3. Make sure the X01 (wire 12 and 13) is well connected to the map
4. Change the faulty contactor



### Meaning:

The signal passing through the contactor is ON when it should be OFF. The contactor has a defect and produces steam when it should not.

**CAUTION : switch the humidifier off before any handling**

### In this case:

When this message appears, the cylinder is drained, the general fault contact is activated, and the unit is then stopped.

### Causes and remedies:

1. Turn off the device
2. Check the condition of the contactors visually
3. Make sure the X01 (wire 12 and 13) is well connected to the main board
4. Change the faulty contactor



### Meaning:

The water inlet valve is defective, the high level is not reached after 20 minutes.

### In this case:

When this message appears, the cylinder is drained, the general fault contact is activated, and the device is not stopped.

### Causes and remedies:

1. Make sure the water supply faucet is open
2. Check for water in the cylinder
3. Change the water inlet valve

# ELECTROVAP® ELMC

Alarm  
P4



INFORMATION "NO INLET WATER"

## Meaning:

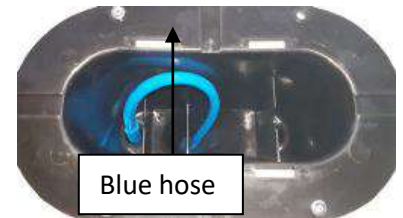
The water supplement of the cylinder is not done properly

## In this case:

When this message appears, the cylinder is drained, the general fault contact is activated, and the device is not stopped.

## Causes and remedies:

1. **Check water supply.** The pressure must be constant and between 2 and 8 bar. If in doubt, install a pressure regulator set at 2 bar on the supply pipe. Also check the condition of the water inlet valve, the electrical connection and the condition of fuse F2 (2A). Change the valve and fuse if defective.
2. **Blue hose inside the filling cup incorrectly positioned or pinched.** Replace the hose as shown in the picture.
3. **Check for proper condensate drainage.** Must absolutely be drained, otherwise it will accumulate in the steam hose, creating water projections and pressure rise in the tank, preventing the unit from being filled.
4. **Verify that the bleed valve is properly closed.** A piece of scale can block the valve closure and cause a leak, preventing proper filling of the unit.
5. **Electronic issue.** Replace the main board and check that there is no steam or water flow in the electrical compartment.



Alarm  
P5



Information "SEE DRAIN CIRCUIT"

**Meaning:** Draining is not done properly

## In this case:

When this message appears, the cylinder is drained, the general fault contact is activated, and the device is not stopped.

## Causes and remedies:

1. Check the condition of the F3 fuse, if defective, change it.
2. Clean the draining circuit, in case a piece of limestone blocks.
3. Check how the coil valve works, if defective, change it.

# ELECTROVAP® ELMC

Alarm  
P8



Information "CLEAN CYLINDER + DRAIN VALVE"

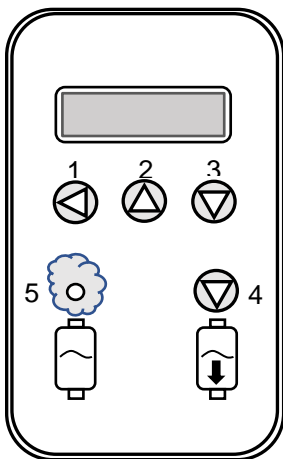
**Meaning:** Draining is not properly done

**In this case:**

When this message appears, the cylinder is drained, the general fault contact is activated, and the device is stopped.

**Causes and remedies:**

1. The drain system is clogged. Press the manual drain button, and check for the proper flow of water. Then clean the inside of the cylinder. Check if there is limestone in the valve.



**TO CARRY OUT A RESET FOR THE ABOVE  
MESSAGES, FOLLOW THIS PROCEDURE:**

- Switch the unit to drain by pressing the manual drain button (4).
- Press button 3 for at least 5 seconds.

## 6 MAINTENANCE

### 6.1 GENERAL INFORMATION

#### Periodic checks

- After an hour of operation, check for no water leaks in the middle and foot of the cylinder.
- After 50 hours of operation, check the condition of the cylinder. Make sure no arcing or flicker occurs between the electrodes during operation.

Check the filter inside the water inlet valve as well as the drain system.

Please re-examine all the power cable connection terminals, as well as the clamps of the various pipes (steam, drain, inside the wet part).

**WARNING!** Tighten the clamps when the cylinder is cold.

- After a year of operation, please check the condition of your steam hose, water drain and the internal pipes of the unit. If some pipes seem damaged, it is essential to change them. Please tighten all connection terminals.

#### Warnings

After a prolonged use or with the use of high TH water, may be solid deposits on the electrodes which can increase the concentration of water.

If electrical arcs appear inside the cylinder, your humidifier works under abnormal conditions and these arcs can cause:

- A significant heat increase that could overheat the plastic and even melt it, causing a hole and then a leak into the unit.
- A disjunction of the device due to a high intensity created by the electrical arcs.
- Premature deterioration of heating electrodes.
- Burning of electrodes power cables.

#### In case of electric arcs

Check any points in case electrical arcs appear inside the cylinder:

- If your water is running with softened water, make sure your softener does not release salt into the appliance's water supply pipes.
- Make sure the drain valve is working properly and maintain it.
- Check F3 drain valve fuse on the main board.



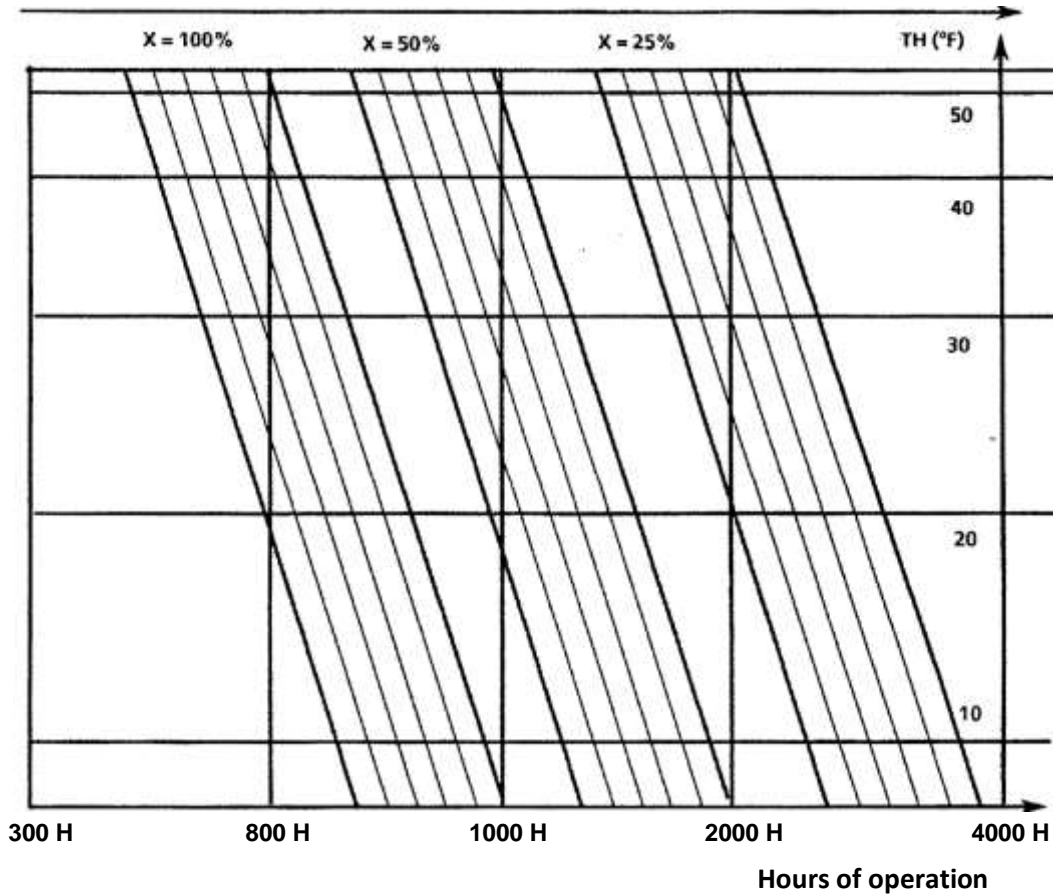
The humidifier has powered electrical components and the cylinder has heated elements. Therefore, all work must be carried out by qualified and competent personnel. Before working on the cylinder, make sure that the humidifier is switched off.

# ELECTROVAP® ELMC

## 6.2 STEAM CYLINDER CLEANING

### ESTIMATED CYLINDER MAINTENANCE CURVE

X – steam demand



Example: for a humidifier operating at 100% capacity, using water with TH20, the cylinder will need to be cleaned or changed after 800-900 hours of operation.

- The water hardness is expressed in French degrees. The value thus expressed refers to the Total Hardness of the water (TH).
- The water quality must be specified when choosing your unit in order to adapt the cylinder to your type/quality of water.

### ELECTRODE CHANGE

	Original length	
Type	ELMC 5 to 15	ELMC 20 to 90 and ELMC 10 MONO
Length [mm]	160	250

The electrodes must be changed when their length is less than 1/3 of the original length.

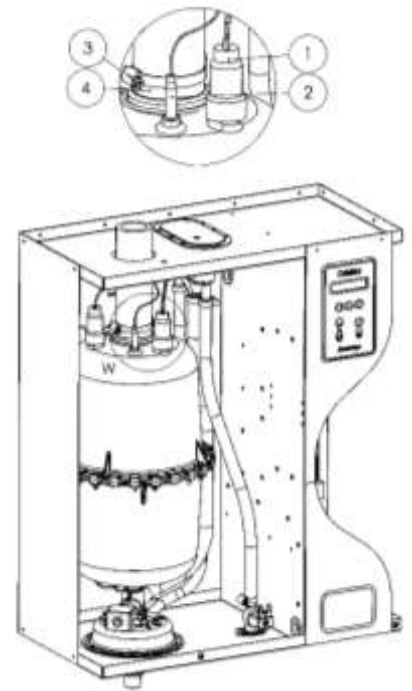
ElectroVap ELMC are equipped as standard with cleanable cylinders that can be disassembled using two 8 keys.



# ELECTROVAP® ELMC

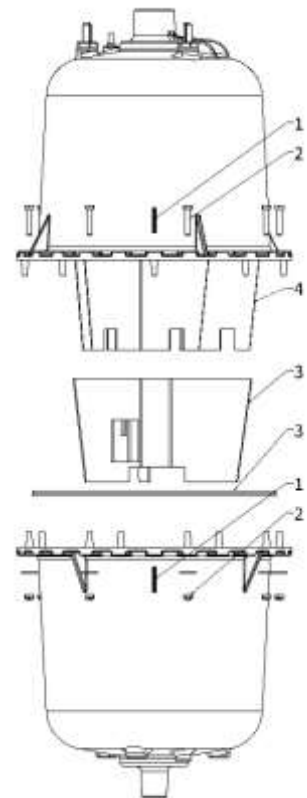
## CYLINDER REPLACEMENT METHOD

- **Drain the cylinder** by pressing the drain button and wait until the cylinder is completely empty. The message "DRAINING CYCLE OVER" appears.
- **Turn off power** of the power circuits (in the general electrical cabinet) and control system located on the front of the device.
- **Remove the door from the hydraulic compartment, remove the power cable connectors and water level sensor (1 and 2).** Then loosen the clamp to disconnect the steam outlet hose (3 and 4).
- **WARNING! Risk of burns.** If the drain is recent, the steam cylinder is still burning. Therefore, wait for it to cool down.
- **Lift the cylinder up** by pressing down on its base to release it from the foot of the drain valve.
- **Remove the top of the cylinder from the retaining clip** and remove it from the hydraulic compartment.
- Please tighten the steam hose slightly on the cylinder, **only when the cylinder is cold, to avoid deformation.**



## CYLINDER CLEANING METHOD

- After removing the cylinder, mark the two half-cylinders (1) at once.
- Remove the nuts and screws holding with two keys of 8 (2), open the cylinder. Remove the strainer and seal, then clean them (3).
- Clean the electrodes, the brace, and the inside of the cylinder's bodies by scraping the limestone (it is possible to use passed acid for power electrodes) (4).
- Rinse the electrodes, the bodies of the cylinder, the brace. Do not forget to clean the strainer in the cylinder foot.



**WARNING!** Never shake the edge of the cylinder shells to remove limescale. It is imperative to systematically replace the cylinder seal and reposition it in its housing. Always replace the sealing ring and insert it into the profile of the lower barrel of the cylinder. Then insert the upper part (electrodes). Make sure to align the two shells, reposition the nuts and screws. Tighten by screwing the screws opposite each other so that the seal is not deformed.



If the power cables change, be sure to run them through the humidifier according to the wiring diagram explained previously.

# ELECTROVAP® ELMC

## 6.3 DRAIN VALVE

The drain valve should be maintained whenever the steam tank is maintained or changed.

- Once the tank is out of the humidifier, disconnect the drain valve supply cables **(Item 1)**.
- Unscrew the nut and the plastic protection of the supply coil **(Item 2 & 3)**.
- Now you can remove the coil **(Item 4)** from the valve body **(Item 5)**.
- Use a pair of pliers or a 19" wrench to unscrew the valve plug **(Item 6)** from the valve body **(Item 5)**.
- Check and clean, if necessary, the inside of the valve body by running water through the hole.

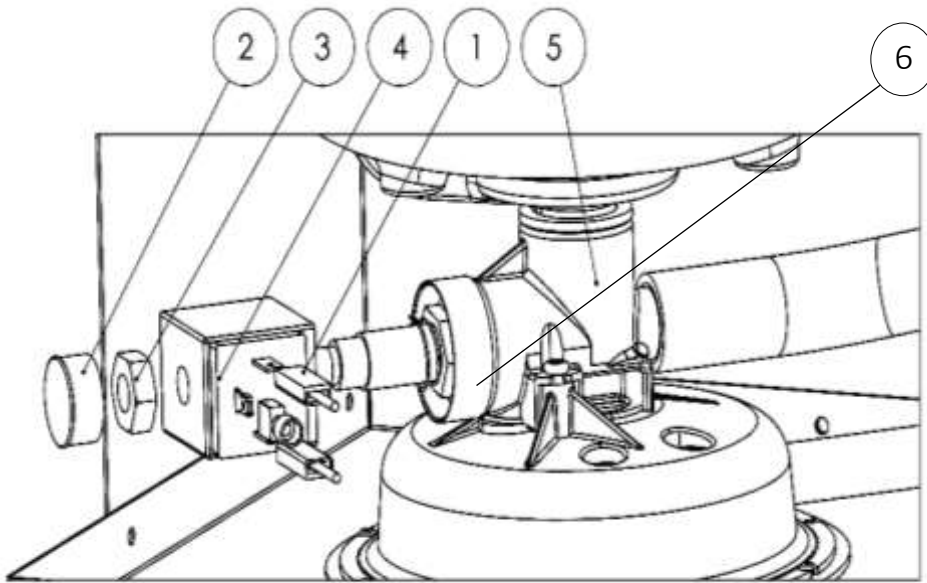


Fig. 6-3. Humidifier drain valve

Reassemble the drain valve as original, before repositioning the tank, by proceeding as follows:

1. Position the tank bottom in the valve connection, push down.
2. Replace the steam hose and do not forget to tighten the hose clamp.

**Ensure that all the clamps are properly tightened whenever the humidifier is maintained.**

## 6.4 WATER INLET VALVE

Maintenance of the water inlet valve is to be done after the first 50 hours of operation. Thereafter, twice a year (minimum).

- Switch the appliance off.
- Switch off the water supply to the humidifier and unscrew the water supply hose.
- Disconnect the power cables from the water inlet valve of your humidifier (Item 1).
- Loosen the clamp and remove the water supply hose. (Item 2)
- Unscrew the two screws securing the valve (Item 3).
- Pull out your valve, remove the filter with pliers and remove the coil (Item 4) by prying it off with a screwdriver.
- Run water through the valve body and over the filter to remove any particles.

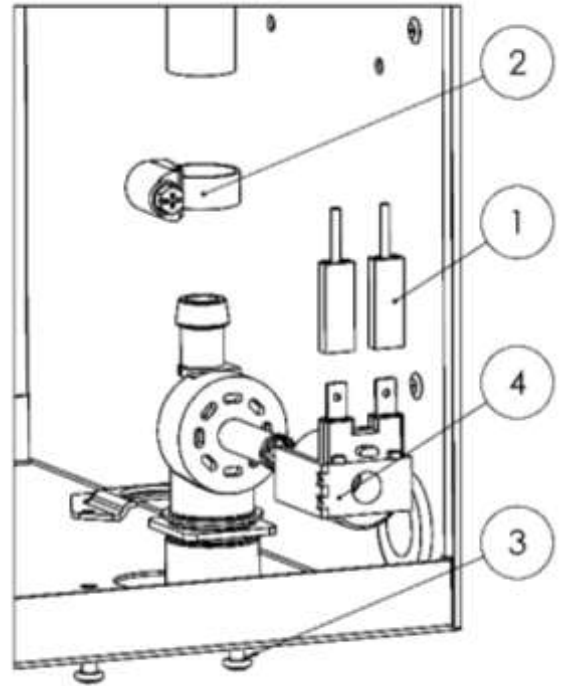


Fig. 6-4. Humidifier water inlet valve

Once all these operations completed, please reassemble the unit, taking care to check the condition of the water supply hose clamp. You can put your appliance back into service.

**Ensure that all the clamps are properly tightened whenever the humidifier is maintained.**

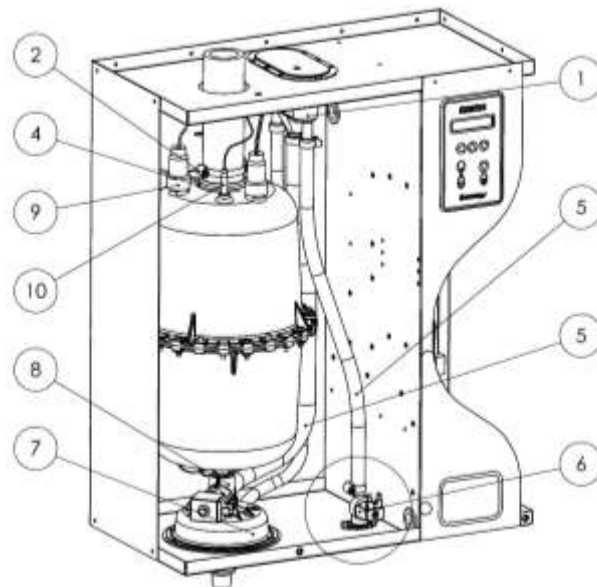
# ELECTROVAP® ELMC

## 7 SPARE PARTS

### 7.1 HYDRAULIC PART

N°	Code	Description
1	D110136-SC-SP	Complete filling cup for 1 SC
	D110136-MC-SP	Full filling cup for 1 MC
2	D110146-SP	Tightening clamp - 12x22mm
	D110139-SP	Tightening clamp - 16x27mm
	D110140-SP	Tightening clamp - 20x32mm
	D110141-SP	Tightening clamp - 25x40mm
	D108256-SP	Tightening clamp - 40x60mm
4	D110195-SP	Cylinder maintenance kit for 1 SC
	D110196-SP	Cylinder maintenance kit for 1 MC
5	D61898	Pipe - 13/19mm (water supply hose)
	D61899	Pipe - 19/26mm (overflow and cylinder filling hoses)
6	D110157-SP	Water inlet valve ELMC 5-30
	D110771-SP	Water inlet valve ELMC 40-90
7	D110154-SP	Drain cup (upper part)
	D110154-SP	Drain cup (lower part)
8	D116726-24-SP	Complete drain valve 24V
	D110148-24-SP	Operator with 24V coil for drain valve
	D110149-SP	Drain valve body
	D116656-24-SP	Drain valve coil 24V
	D110153-SP	Bag of 10 drain valve gaskets
9	D119698-1SC-SP	3-cable cylinder 1 SC power kit
	D119698-1MC-SP	3-cable cylinder 1 MC power kit
	D119698-2MC-SP	3-cable cylinder 2 MC power kit
	D119698-3MC-SP	3-cable cylinder 3 MC power kit
10	D119699-1SC-SP	1 SC High Level Electrode Cables
	D119699-1MC-SP	1MC High Level Electrode Cables
	D119699-2MC-SP	2MC High Level Electrode Cables
	D119699-3MC-SP	3MC High Level Electrode Cables

(\*) SC = Small Cylinder - MC= Medium Cylinder



# ELECTROVAP® ELMC

N°	Code	Description
11	D110214-SP	Set of 3 power electrodes for cylinder SC
	D110217-SP	Set of 3 power electrodes for cylinder MC
12	D110212-SP	SC cylinder seal
	D110213-SP	MC cylinder seal
13	D110221-SP	Brass nut for electrode (Bag of 3)
15	D110233-SP	Bag of screws, nuts, cylinder washers
16	D110209-SP	High level electrode with M4 nuts
17	D110200-SP	MC Electrode spacer
18	D110206-SP	SC cylinder filter
	D110207-SP	MC cylinder filter

(\*) SC = Small Cylinder - MC= Medium Cylinder

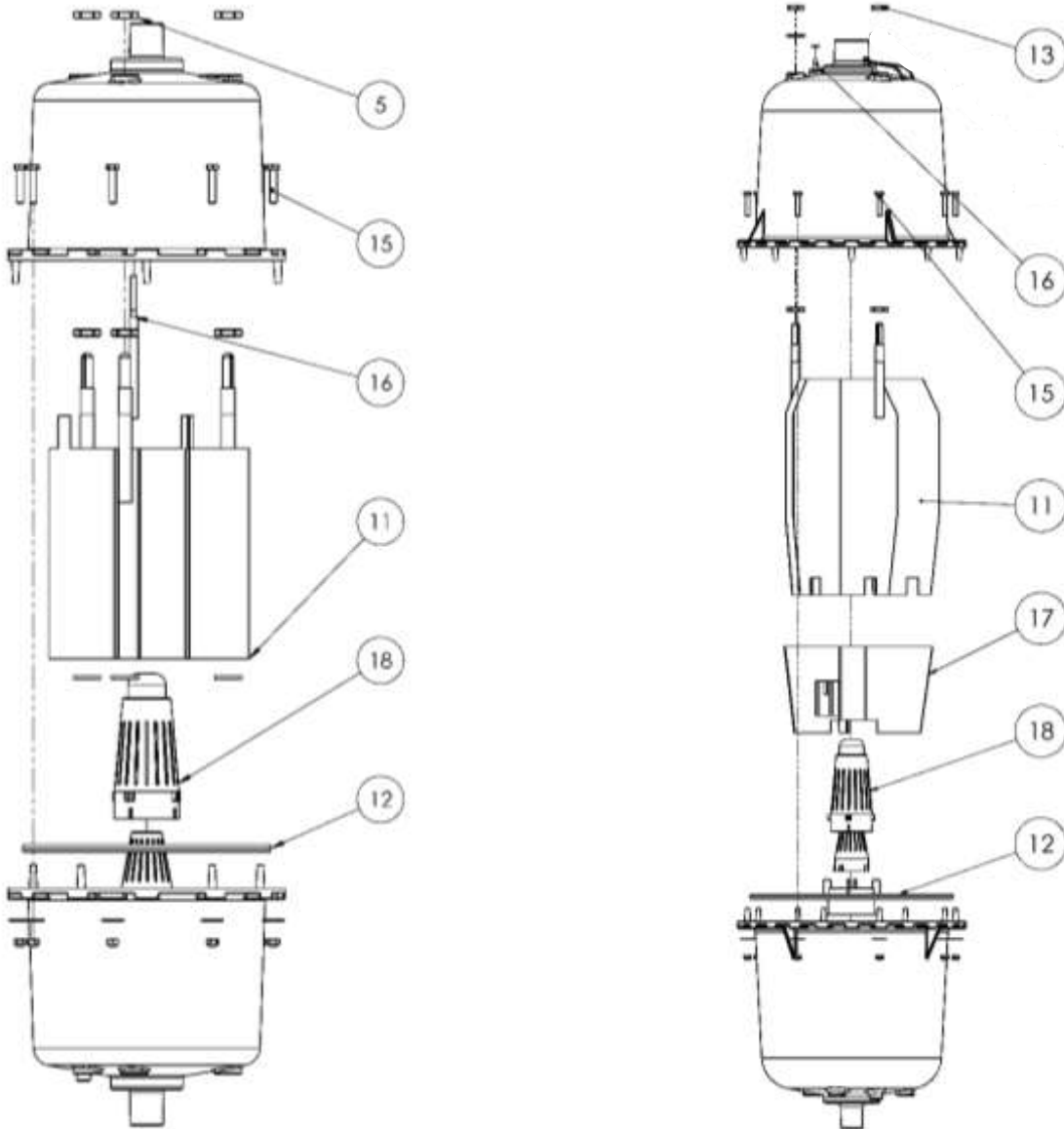


Fig. 7-1. Tank exploded view

# ELECTROVAP® ELMC

## 7.2 WATER INLET VALVE

N°	Code	Description
1-2	D110157-SP	Water inlet valve (1 cylinder)
1-2	D110771-SP	Water inlet valve (2-3 cylinders)
2	D116655-24	Coil 24V
	D116655-24-UL	UL coil 24V
3	D111775-SP	Valve bracket

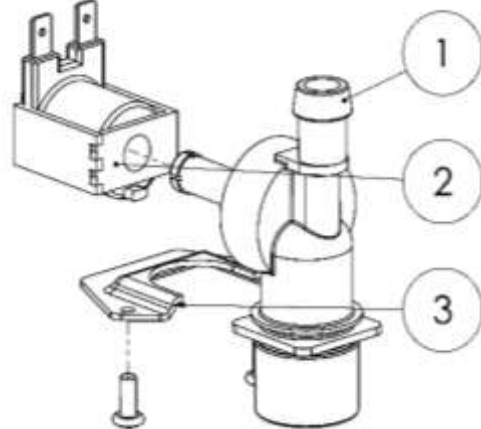


Fig. 7-2. Water inlet valve exploded view

## 7.3 DRAINING CIRCUIT

N°	Code	Description
1 - 5 & 8 - 10	D110147-SP	Complete valve (1 to 5)
1		Adapter ring
2		Protective ring
3	D110153-SP	O-ring seal (set of 10)
5	D110149-SP	Valve body
6	D110154-SP	Drain cup upper part
7	D110155-SP	Drain cup lower part
8	D110148-10-SP	Nut protection
9	D116656-24-SP	Drain valve coil
	D116656-24-UL-SP	UL drain valve coil
4 - 10	D110148-SP	Valve pilot kit 24 VAC
	D110148-UL-SP	Valve pilot kit 24 VAC (UL)



Fig. 7-4. Draining circuit exploded view

# ELECTROVAP® ELMC

## 7.4 ELECTRICAL PART

N°	Code	Description
20	D121389-1-SP	Main Board ELMC 5-30 (1TI)
	D121388-1-SP	Main Board ELMC 40-90 (0TI)
21	D110766-SP	Board / module 2 TI ELMC 40-60
	D110186-SP	Board / module 3 TI ELMC 70-90
22	D50931-SP	Remote information board
23	D110124-SP	Display Board
24	D50932-SP	Contacteur 24 VAC
25	D92393-SP	Switch on/off
26	D110128-50-SP	Transformer: Prim: 2x115V / Sec: 2x12V
27	D116631-SP	Fuse fast 2A (Bag of 6)
28	D116718-SP	Fuse fast 5A (Bag of 6)
30	D109737-SP	Terminal block 35mm <sup>2</sup> (L1, L2, L3)
31	D110168-SP	Terminal block 16mm <sup>2</sup> (L, N)
32	D110768-SP	Fuse protection terminal 6mm <sup>2</sup> .
33	D107491-SP	Terminal block (1, 2, 3, 4)
34	D110166-SP	End terminal block
35	D110163-SP	Ground terminal block 35mm <sup>2</sup>

Location	Amp.	Fuse protection
F1	2AT	Power contactor coil
F2	2AT	Inlet valve coil
F3	2AT	Drain valve coil
F4	2AT	Electronic boards
Din rail 5 & 6	2AT	Transformer
Din rail 7 & 8	5AT	Transformer

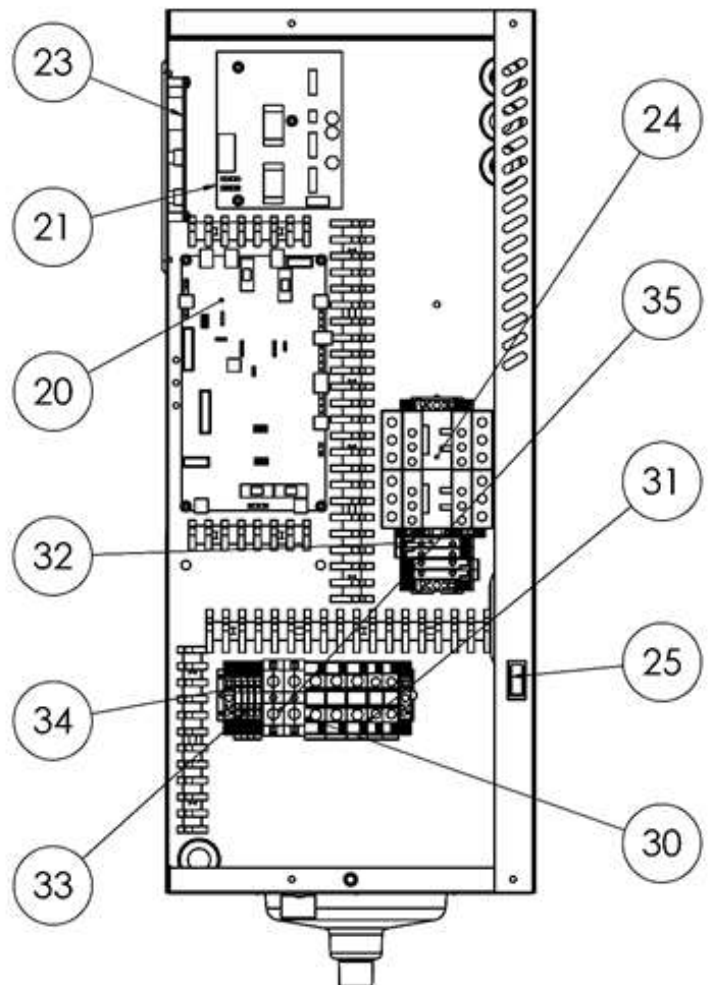


Fig. 7-5. Humidifier electrical compartment



185, Boulevard des Frères Rousseau  
76550 Offranville – France  
[www.devatec.com](http://www.devatec.com)

**Export**→ Tel. +33 (0)2 35 83 06 44  
Email : [export@devatec.com](mailto:export@devatec.com)

**France**→ Tel. +33 (0)2 35 04 61 41  
Email : [france@devatec.com](mailto:france@devatec.com)

Devatec continues to develop its products. For this reason, product features and specifications may change without notice.

This is a translated version of the original version.

**ELMC – 07/21 Edition - V 3.0.X program version**