

Electrode steam humidifier

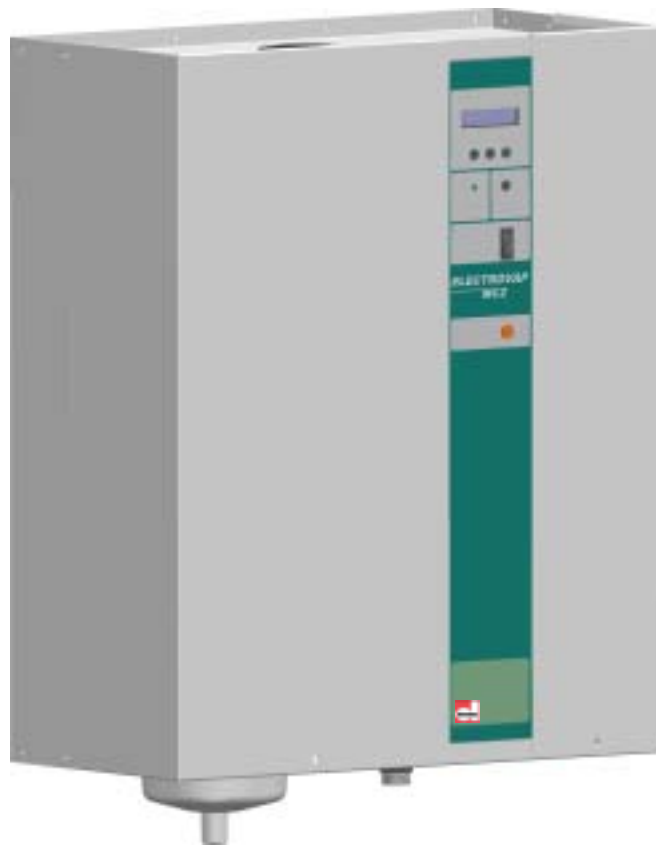



ELECTROVAP MC2

Table of Contents

Safety information	3-4
Accreditation	5
RoHS declaration	6
Delivery contents	7
Dimensions & weights	8
Humidifier component part overview	9
Wall installation	
Installation steps	10
Step 1 - Placing and wall attachment	11-12
Step 2 - Water connection	13
Step 3 - Steam pipe positioning	14 to 21
Step 4 - Condensate outlet	22
Step 5 - Electrical connections	23 to 36
Step 6 - Control connection	37
Setting up	38
System management	
User information menu	39-40
Humidifier status menu	41
Configuration changing menu	42 to 44
Maintenance	
Cylinder maintenance guide	45
Precaution	46
Displayed messages	47
Maintenance	
Alerts	48-49
Main board changing	50
Steam cylinder cleaning	51
Valves maintenance	52-53
Spares lists	54 to 57

IMPORTANT

Please read, heed and follow the enclosed safety information and the warning labels inside the humidifier before installation or maintenance.

Warnings & safety symbols



Warning : This symbol is used to designate a danger of injury or potential damage to the system.



Caution : High voltages are present inside the humidifier. All works concerned with the electrical installation must be carried out by skilled and qualified personnel.



Caution : Danger of scalding ! The ElectroVap MC2 generates steam during operation and therefore surfaces and pipe-work become very hot. Ensure that equipment not sustaining high temperatures be kept away.



Warning : the end user should ensure that the equipment be disposed of according to the local prevailing regulations.

Delivery and storage

Any loss or damage during delivery should be reported to carrier by registered letter within 3 working days and be advised to **devatec** or to authorized dealer.

It is recommended that the ElectroVap MC2 humidifier be kept in its transit packaging for as long as possible prior to maintenance. If the humidifier is to be put into storage prior to installation, it must be stored under cover and protected from physical damage, dust, frost, rain and humidity. More than 6 months storage is not recommended.

GENERAL



This manual contains all details necessary for the planning and installation of the ElectroVap ELMC2 humidifier. In addition commissioning and maintenance details are included.

The manual is intended for use by engineers and properly trained technical personnel. Maintenance, servicing or repair work must only be carried out by suitable skilled and qualified personnel, the customer must be responsible for ensuring their suitability.

Any risks or hazards, especially when working from ladders or towers should be identified by a skilled and Health and Safety representative and effective control measure put in place.

No liability will attach to the Distributor if any damage, injury or accident is attributable to inattentive, inappropriate, negligent or incorrect operation of the machinery whether or not caused deliberately. Always isolate all electrical and water supplies before commencing any maintenance.

Every effort has been made to ensure details contained in this manual are correct, however, in view of the wide range of conditions experienced in air handling systems, the information provided should only be used as a guide. Please contact your Agent if any doubt.

Correct use

ElectroVap MC2 humidifiers are **ONLY** intended for use with air handling systems or direct air humidification. **ANY OTHER APPLICATION IS NOT CONSIDERED USE FOR THE INTENDED PURPOSE. THE MANUFACTURER CANNOT BE MADE LIABLE FOR ANY DAMAGE RESULTING FROM INCORRECT USE.**

Water

ElectroVap MC humidifiers are designed to be used with mains, demineralized R/O or softened water. On no account attempt to introduce any other fluid or chemical into the system. Water supply should not exceed 6.0 bar and installation should comply with local regulations.

Electricity



All work concerned with electrical installation **MUST** only be performed by skilled and qualified technical personnel (eg electrician or technicians with appropriate training). The customer **MUST** be responsible for ensuring their suitability.

It is the duty of the installer to ensure that suitable sized cables and MCB protection is provided. Please observe the local regulations concerning the provision of electrical installations.

Warranty

A two year warranty term—materials and workmanship—is applicable to the parts of the ElectroVap MC2 to the exception of the consumable parts (valves, cylinders or parts of cylinders) provided our recommendations of use & maintenance have been adhered to. Failure to specify and fit original parts and accessories will invalidate our warranty.

NOTE

The manufacturer's policy is one of continuous research and development. He therefore reserves the right to amend without notice the specifications given in this document.

The photographs are for illustrating purposes only.



ELECTROVAP MC2

Product accreditation

CE APPLIED DIRECTIVES

Electromagnetic Compatibility Directive : **89/336/EEC, 2004/108/EC**
Low Voltage Directive : **73/23/EEC, 2006/95/EC**
Machinery Directive : **98/37/EC Amending Directive 89/392/EEC**

Standard(s) to which Conformity is declared :

EN 61000-6-3 : Electromagnetic compatibility generic requirements (residential, commercial and light industries)

EN 55022 class B conducted and radiated emission limits)

EN 61000-6-2 : Electromagnetic compatibility (EMC) – Generic standards –Immunity for industrial environments;

EN 61000-4-3 : Radiated, radio frequency, electromagnetic field immunity test.

EN 61000-4-6 : Immunity to conducted disturbances induced by radio frequency fields

EN 61000-4-4 : Electrical fast transient/burnt immunity test

EN 61000-4-5 : Surge immunity test

EN 61000-4-2 : Electrostatic discharge immunity test

EN 60204-1 : Safety of machinery – Electrical Equipment of machines – Part 1 : General requirements

EN 292 Parts 1 & 2 : Safety of machinery basic principle mechanical design.

Manufacturer's Name and Address

DEVATEC SAS
Rue Saint Eloi
76550 Ambrumesnil - FRANCE

Authorised Representative

Type of equipment

ELECTROVAP MC

Model Name (s) & Series:

ELMC

Year of Manufacture

2001

We the undersigned, hereby declare that the equipment specified above conforms to the above Directive(s) and Standard(s).

Mr FRAMBOT Jean-François
Managing Director
Date : 02.07.2007



ELECTROVAP MC2

RoHS declaration

devatec sas

Rue Feu St Eloi
76550 Ambrumesnil
France

Confirms that the ElectroVap ELMC steam humidifier is manufactured in compliance with the European regulations 2002/95/EU (RoHS).

This guideline regulates after July 1st 2006 the use of mercury, cadmium, lead (soldering processes), chrome VI as well as PBB and PBDE. ELMC steam humidifiers manufactured previously to this date may contain above materials.

Name : MINFRAY Jean-Marie
Position : R&D Engineer
Date : 05.06.2008

Signature:

A handwritten signature in black ink, appearing to be 'JM' with a flourish.



Any loss or damage during delivery should be reported to carrier by registered letter within 3 working days and be advised to **devatec** or to authorized dealer.

It is recommended that the ElectroVap MC2 humidifier be kept in its transit packaging for as long as possible prior to maintenance. If the humidifier is to be put into storage prior to installation, it must be stored under cover and protected from physical damage, dust, frost, rain and humidity. More than 6 months storage is not recommended.

What is in the box :

1. One ElectroVap ELMC2 steam humidifier supplied with one, two or three disposable or cleanable cylinder(s) according to the purchased model together with an on/off or proportional control.
2. One 500mm long flexible hose with 3/4" thread (with washers) for tap water connection.
3. Ø 25 mm drain hose :
ELMC 1 cylinder : 1 m. long
ELMC 2 cylinders : 2 hoses of 1 m. long and 1.2 m. long respectively
ELMC 3 cylinders : 3 hoses of 1 m. long, 1.2 m. long and 1.8 m. long
4. Hose clamps :
ELMC 1 cylinder : 3 clamps (2 pieces for the steam hose & 1 piece for the drain hose)
ELMC 2 cylinders : 6 clamps (4 pieces for the steam hoses & 2 pieces for the drain hoses)
ELMC 3 cylinders : 9 clamps (6 pieces for the steam hoses & 3 pieces for the drain hoses)

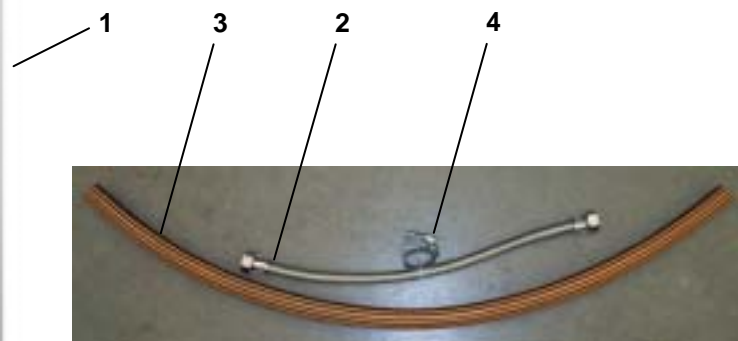

ELECTROVAP MC2

Dimensions & Weight

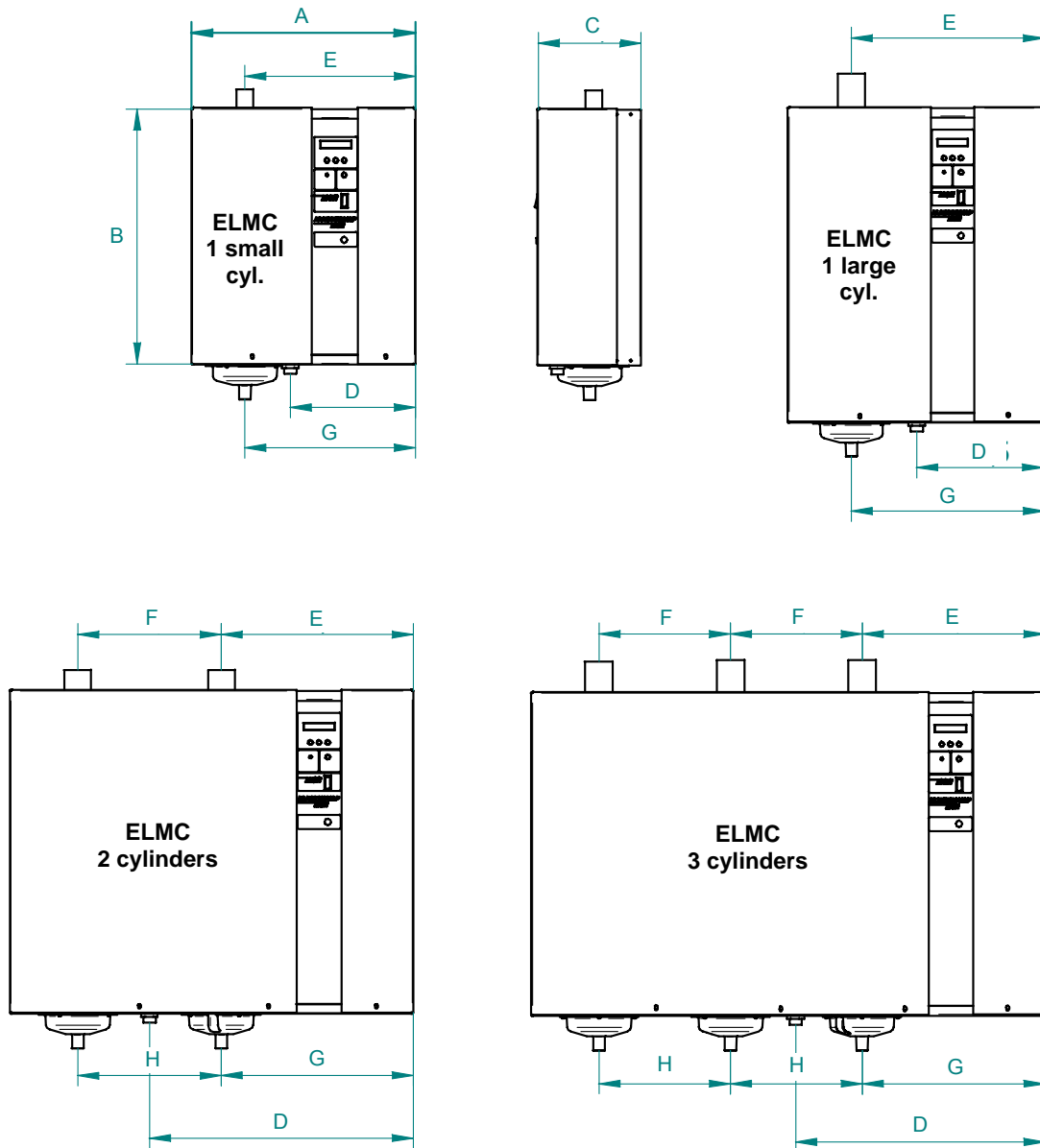

Model	Dimensions in mm								Weight in Kg	
	Humidifier			Water inlet	Steam outlet	Steam outlet spacing	Drain outlet	Drain outlet spacing	Empty	Operating
	A	B	C	D	E	F	G	H		
ELMC 1 SM CYL	475	540	217	215	355	/	355	/	15	23
ELMC 1 LG CYL	550	680	272	270	410	/	410	/	22	37
ELMC 2 CYL	845	680	272	270	400	300	400	300	30	60
ELMC 3 CYL	1075	680	272	270	380	275	380	275	45	90

- SM CYL = small cylinder, LG CYL = large cylinder

ELMC 5-30 humidifier split view

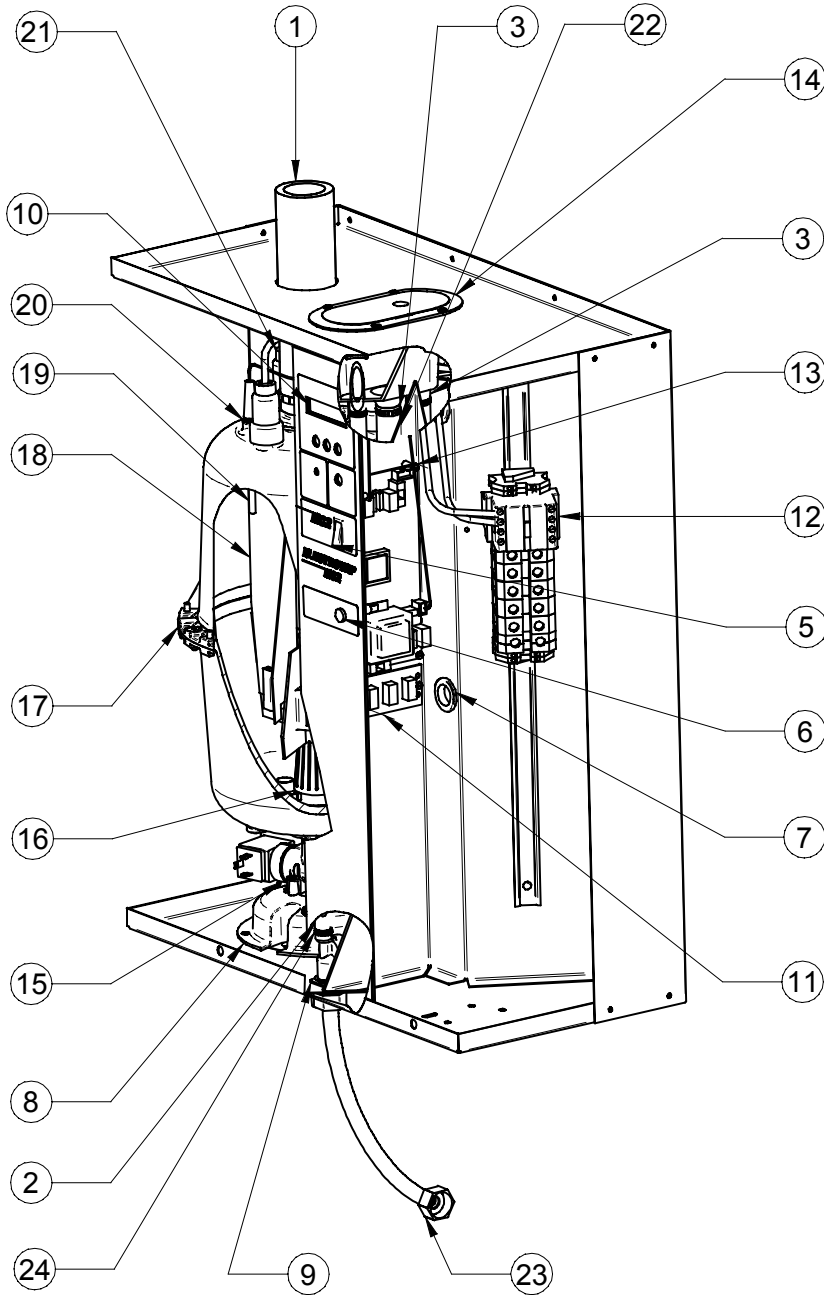

- 1 Steam hose
- 2 Water feed hose 12x16mm
- 3 Hose clamp 16x25mm
- 4 Overflow water hose 18x22mm
- 5 On/off rocker switch
- 6 Stand-by lamp
- 7 Grommet
- 8 Drain cup (upper)
- 9 Water inlet valve
- 10 LCD display board (Ref 500600/3)
- 11 Remote information board (option)
- 12 Power contactor
- 13 Main circuit board (Ref 500101/05)
- 14 Filling cup
- 15 Drain valve
- 16 Cylinder strainer
- 17 Steam cylinder
- 18 Stainless steel electrode plate
- 19 High water level electrode
- 20 High water level electrode cable
- 21 Electrode live power cable
- 22 Cylinder water feed hose 18x22 mm
- 23 Flexible water feed hose 3/4" F
- 24 Hose clamp 12x22 mm



All works concerned with electrical installation must be carried out by a skilled and qualified personnel.

Please read, heed and follow the enclosed information for the installation of the humidifier and the steam, water and electrical networks.

For further technical assistance, feel free to call **devatec**.

Failure to adhere to customer's installation recommendations will invalidate your warranty.

Steps

- Etape 1** - Placing and wall attachment
- Etape 2** - Water connection
- Etape 3** - Steam pipe positioning
- Etape 4** - Condensate outlet
- Etape 5** - Electrical connection
- Etape 6** - Control connection

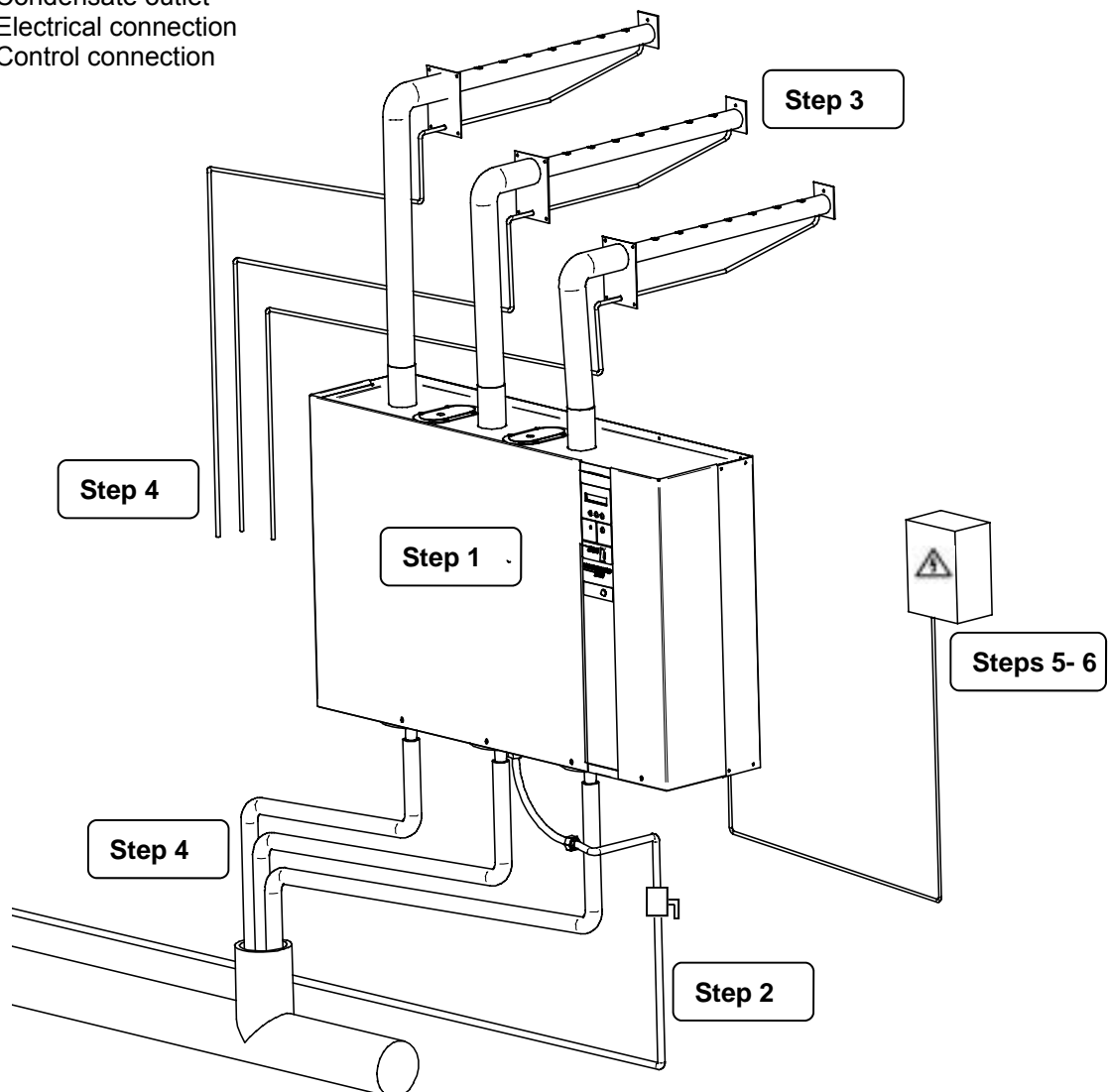

How to install the humidifier on wall

Installation tips :

The humidifier should be operated within 5°C and 40°C in a room with less than 80% of humidity.

When in operation, the rear panel becomes hot (60°C) so do not hang the humidifier on a heat sensitive surface.

The **devatec** humidifiers have been developed to be hanged on wall. Before installation, make sure that the surface material is strong enough to hold the humidifier.

The best performances of the humidifier are achieved when the steam discharge is made at short distance from the humidifier (see after page n°20).

Consider free space around the humidifier to allow easy access for maintenance purposes (s.a. here under sketches).

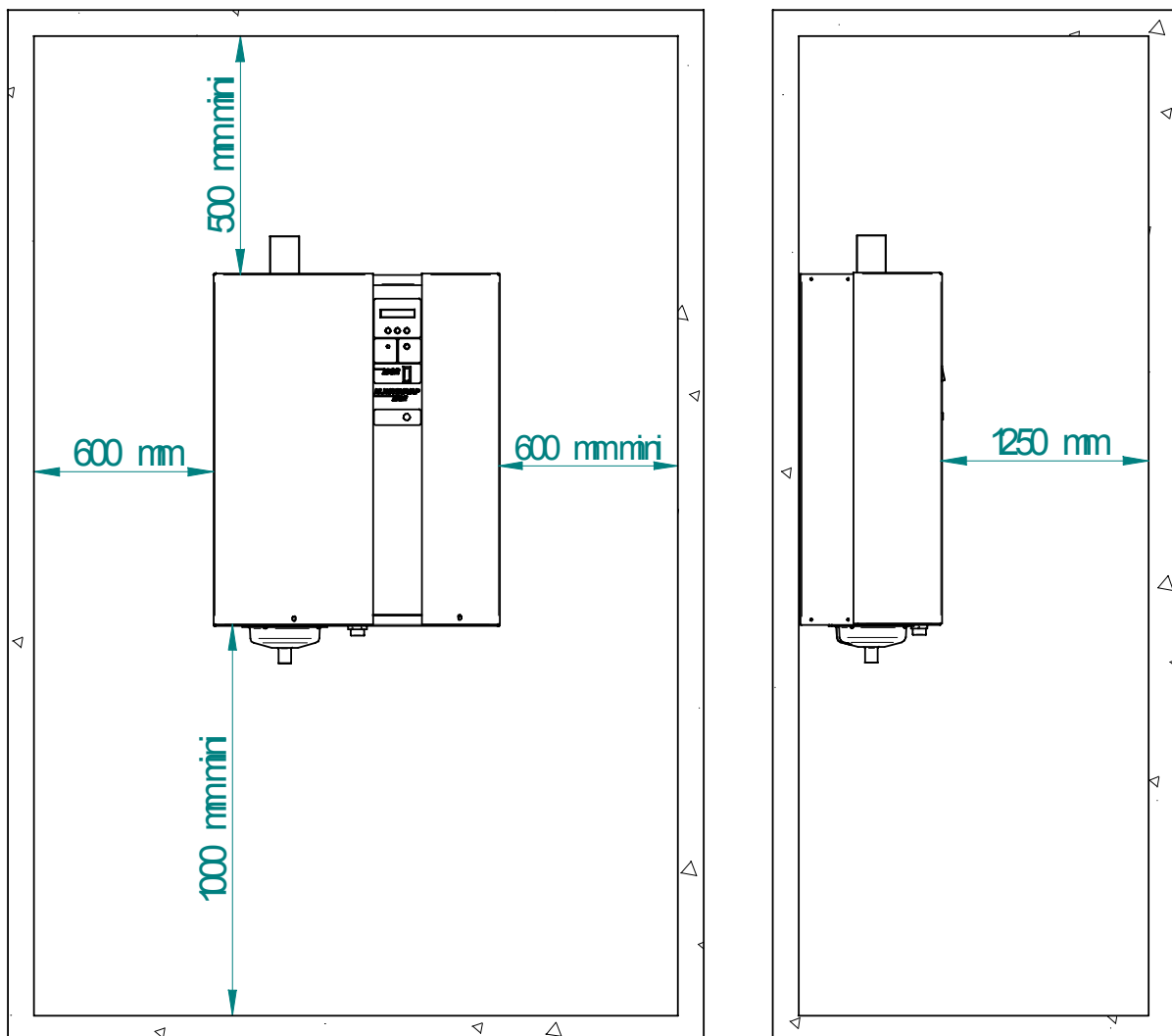

Installation on wall

Nota :

Use installation equipment and material appropriate to the surface on which the unit should be hanged .

The dimensions mentioned underneath are for cabinets without doors.

Method:

Mark and drill the mounting holes for 6 mm screws (s.a. the drilling distance table) :
 ELMC 1 & 2 cylinders : 4 mounting screws—ELMC 3 cylinders : 5 mounting screws

Insert pegs in holes and the upper screws. Allow about 10 mm for hanging the cabinet.

Hang the cabinet and level it vertically and horizontally. Screw up the upper screws and then screw up the lower screws.

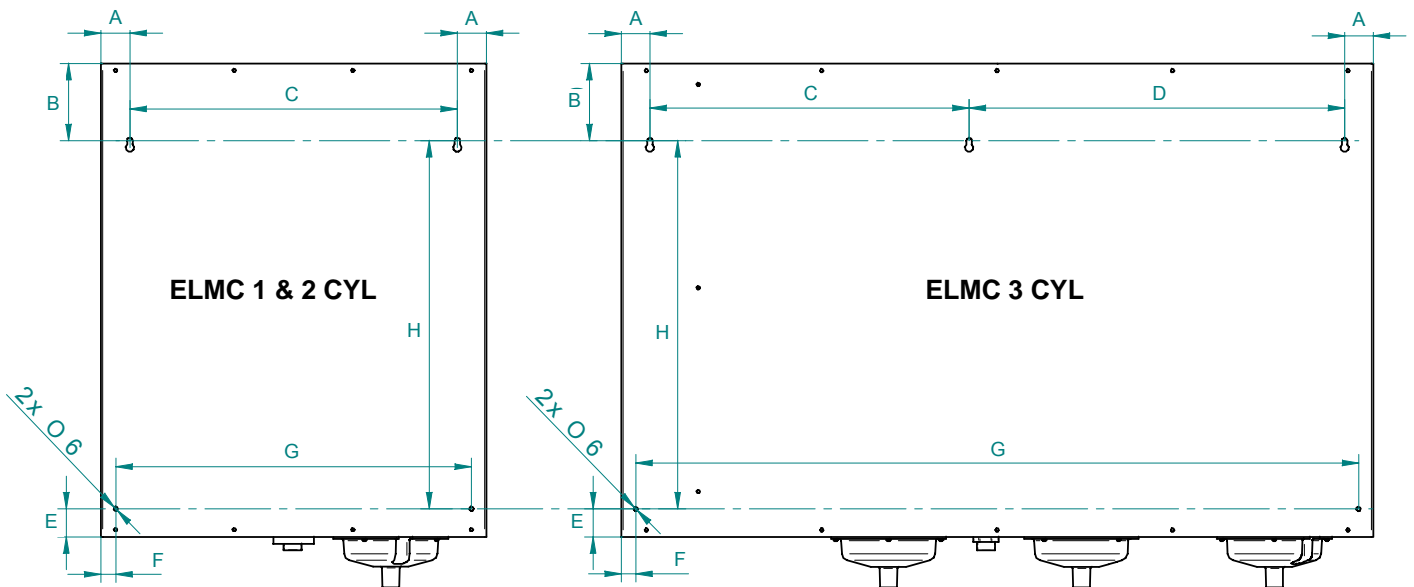

- CYL = cylinder

Model	Drilling distances in mm							
	A	B	C	D	E	F	G	H
ELMC 1 SM CYL	21	110	425	/	40	21	425	385
ELMC 1 LG CYL	41	110	467	/	40	21	507	525
ELMC 2 CYL	41	110	760	/	40	21	800	525
ELMC 3 CYL	41	110	455	535	40	21	1030	525

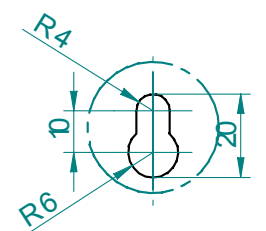

Detail of hanging hole

- SM CYL = small cylinder, LG CYL = large cylinder

WATER CONNECTION

Recommendations :

The operating principle of the electrode steam humidifier is the electrolyse where an electrical current runs through stainless steel electrode plates immersed in water made conductive by the mineral salts it contains.

The ElectroVap humidifier can produce steam from 3 water qualities having the following characteristics :

The water level must be between « a » and « b » for the maximum capacity of the cylinder.

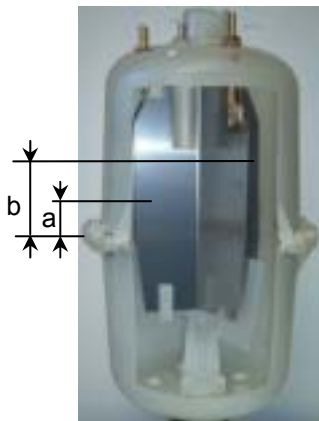

Town water or raw water : the water TH should be **between 0 and 40° French grade** for a conductivity **between 1000µ and 350µS/cm (Micro Siemens per centimetre)**.

Softened water: water treated by sodium/calcium permutation on resins. The titration value TH should be kept as constant as possible and **between 0° and 2°**.

It is essential that the salt maintenance of softeners be programmed for the water volume consumed in order to prevent an excessive salt concentration to humidifier once the regeneration cycle is finished (please refer to the softener's user manual). Duplex softeners are best suited to your humidifier in this regard. In doubt, please consult **devatec**.

Demineralised water: this is a water treatment by reverse osmosis or running through resins.

The ElectroVap humidifier can work with demineralised waters having a minimum water quality of **30µS/cm**. A tea spoon of bicarbonate of soda must be added on start-up to initiate steam production.



No chemical agent whatsoever (chlorine, disinfectant, ozone...) must be added to the water. Some water qualities may generate foam that can disturb the correct functioning of the humidifier. If this occurs to your humidifier, please refer to devatec for further assistance.

Recommendations on water tapping :



A fresh mains cold water service should be used to supply the unit. The water pressure should not exceed 6 bar and should not be inferior to 1 bar with a temperature less than 40°C.

The water supply connection is on the bottom of the unit. All the ELMC are supplied with a 500 mm long water inlet hose with a 3/4" female connection to the cold water supply. **A check valve should be located on the mains and cold water service connection to the unit.**



The ELMC humidifier uses water to produce steam so leakage may happen causing potential damage. If an installation in false ceiling or above prime rooms such as museum, exhibition or laboratory rooms is considered, ensure that the floor below the humidifier is constructed from waterproof materials (with draining facilities) to withstand any water spilling during servicing or if a problem occurs.

STEAM DISTRIBUTION PIPE

Steam from the cylinder enters the duct via a steam distribution pipe. In order to obtain optimum performance of the humidifier, it is recommended that these instructions be adhered to as far as possible.

There are two steam inlet diameters available : Ø 25 mm and Ø 40 mm

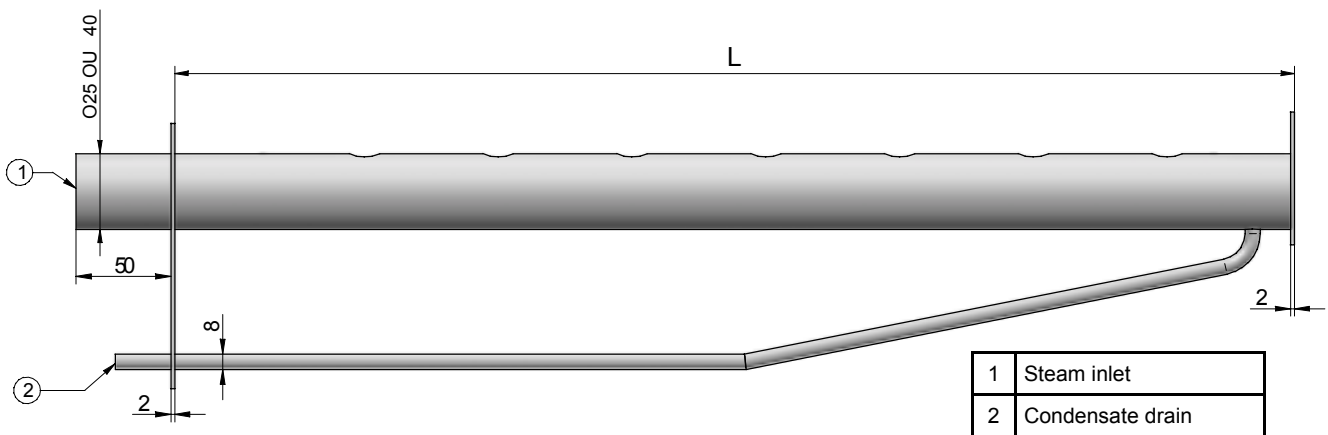

Steam distribution pipe selection table

The number of distribution pipes and the diameters depend on the humidifier model.

ELMC Model	1 SM CYL	1 LG CYL	2 CYL	3 CYL
Number of steam pipe(s)	1	1	2	3
Steam inlet diameter (1)	Ø 25mm	Ø 40mm	Ø 40mm	Ø 40mm
Condensate drain diameter (2)	Ø 8mm	Ø 8mm	Ø 8mm	Ø 8mm

- SM CYL = small cylinder, LG CYL = large cylinder

To get the best steam distribution, select the longest possible distribution pipe to fit the duct.

Standard distribution pipes are available on either diameter in 110, 290, 590, 790, 1000, 1250 and 1500 mm long.

POSITIONING OF THE STEAM DISTRIBUTION PIPE

Evaporation distance or vapor trail « D »

A certain length is required so that the steam coming out of the steam distribution pipe be absorbed by the air. All along this length, described as the evaporation distance, the steam can still be seen in the airflow as a mist which can condensate in water against any obstacle if placed within. To prevent condensation, this evaporation distance should be calculated before positioning the steam distribution pipe.

How to calculate the evaporation distance « D »

In order to determine the evaporation distance, the attached calculation table can be used :

HR1 = relative humidity of air before humidification in %.

HR2 = relative humidity of air after humidification in %.

D	% RH1 inlet air							
	5	10	20	30	40	50	60	70
% HR2 outlet air	Minimum humidification distance « D » in m.							
40	0.9	0.8	0.7	0.5	-	-	-	-
50	1.1	1	0.9	0.8	0.5	-	-	-
60	1.4	1.3	1.2	1	0.8	0.5	-	-
70	1.8	1.7	1.5	1.4	1.2	1	0.7	-
80	2.3	2.2	2.1	1.9	1.7	1.5	1.2	0.8
90	3.5	3.4	3.2	2.9	2.7	2.4	2.1	1.7



minimum humidification distance in meters (m).

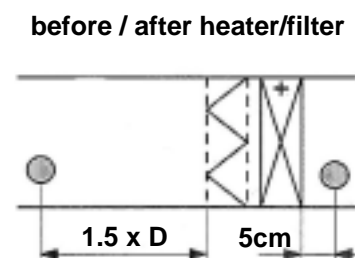
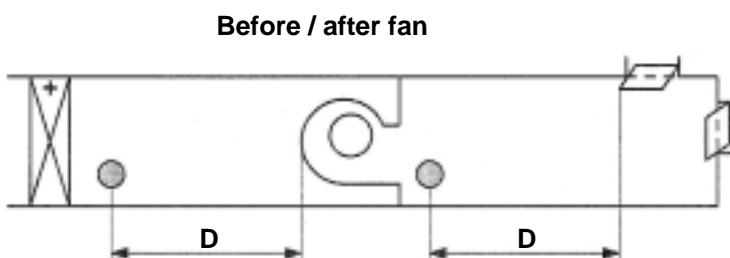

2,5 x D before thin particule filter

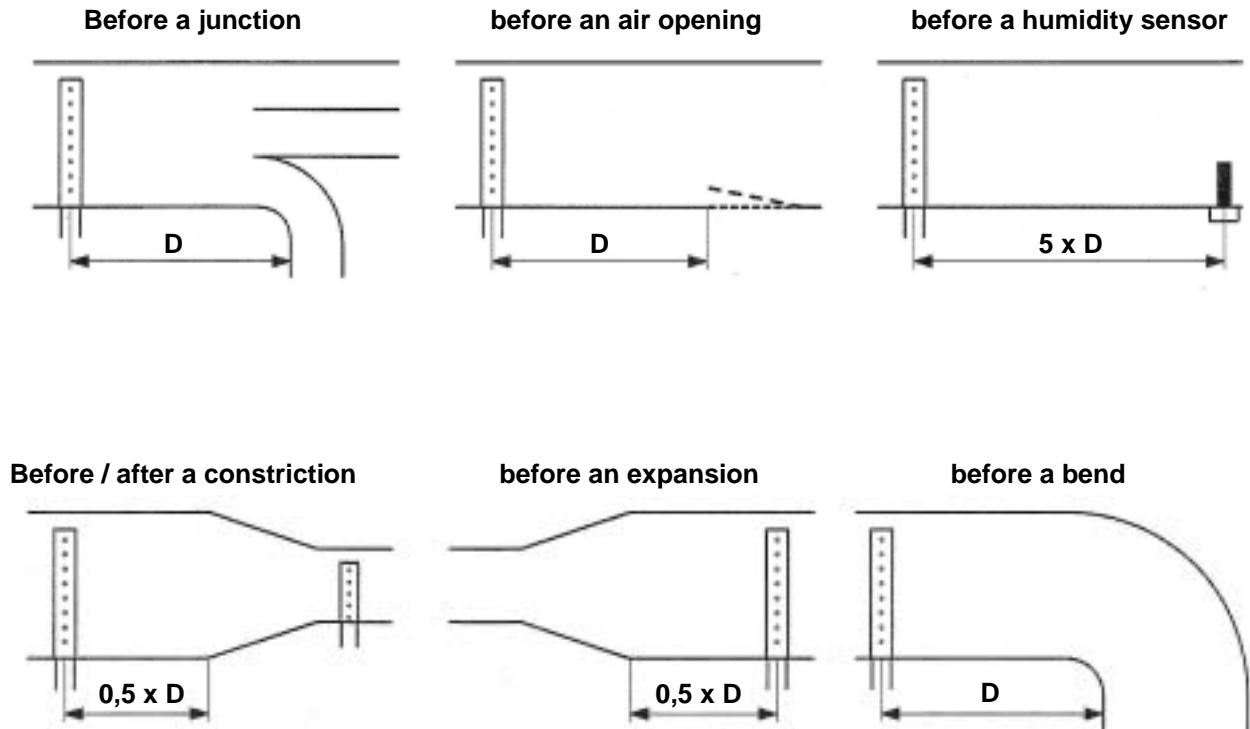

A high humidity limit humidistat must be installed in the duct to stop the humidifier in case the level of humidity exceeds the preset value.



In case the recommended distances cannot be met, please contact **devatec** or their authorized agent for an alternative solution.



If accurate values cannot be reached, a distance of 2 m. should be considered as a minimum distance between pipes & obstruction and 3 / 4 m. before sensor or humidistat.

STEAM DISTRIBUTION PIPE POSITIONING



Please meet the following dimensions and spaces according to your configuration. For further information, please contact **devatec** or their authorized agent.

H1 = 110mm = Minimum height between the duct floor and the axle of the steam pipe.

H2 = 140mm = Minimum distance between two pipes.

H3 = 160mm = Minimum height between the duct top and the axle of the steam pipe.

The H3 distance can be 80 mm at the shortest in case the steam pipe is installed at an angle of 30°.

 The arrow shows the direction of the air flow.

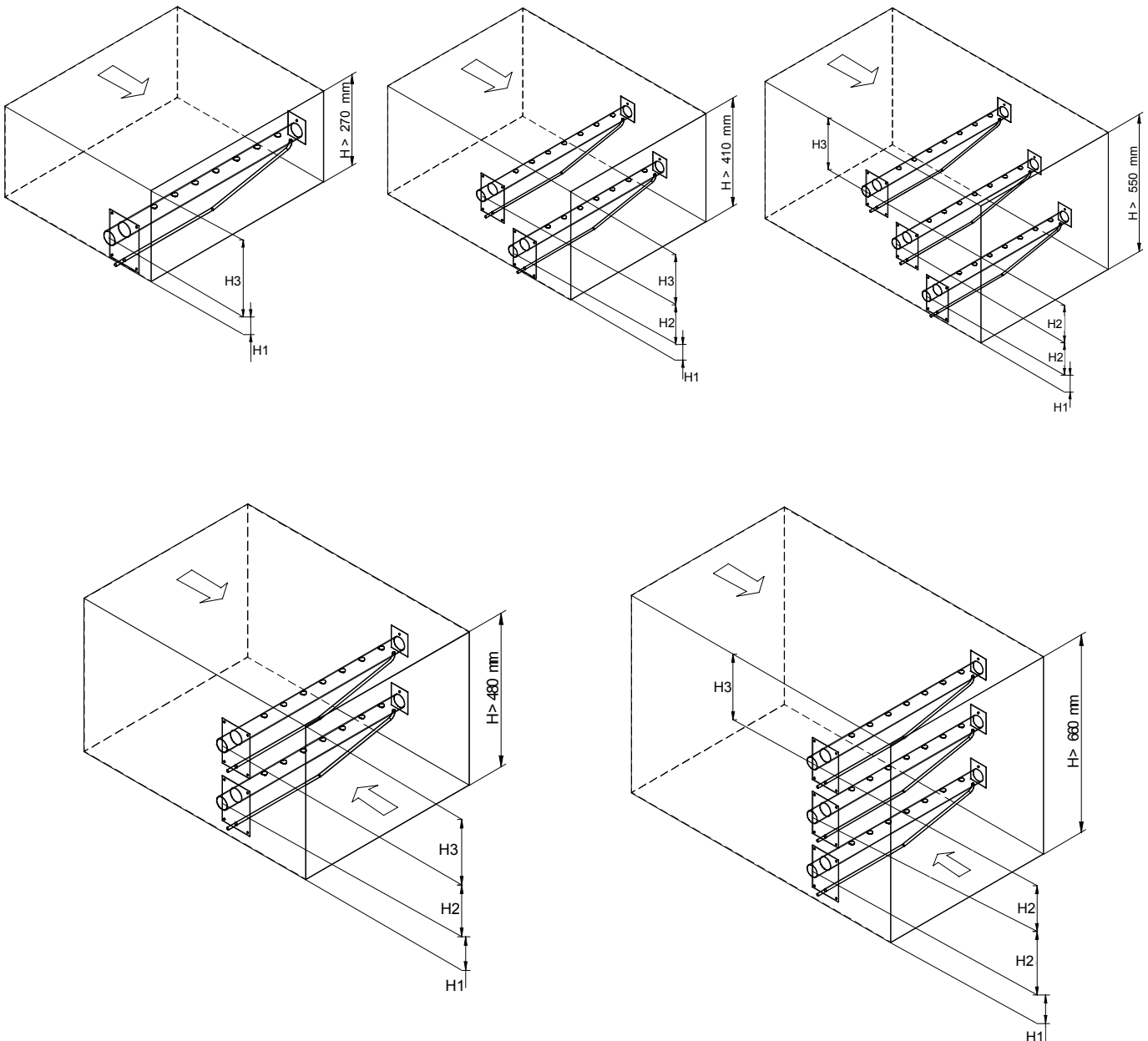

STEAM DISTRIBUTION PIPE POSITIONING

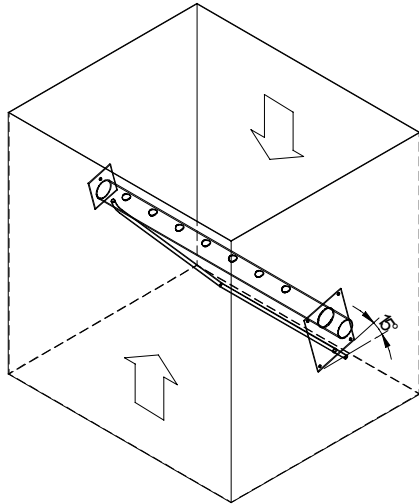

In vertical ducts where the air flow is upward or downward, the steam distribution pipe(s) must be tilted by 15° sideways.

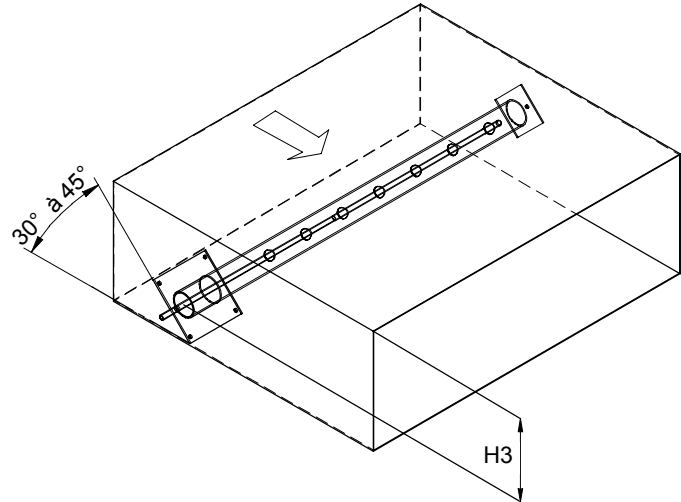

In duct with limited height, the distribution pipe(s) can be tilted by 30 or 45° to get the 80 mm minimum height.

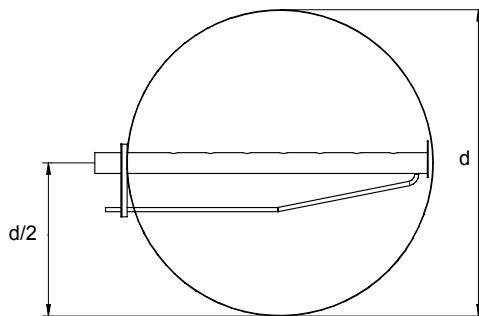

d = Duct diameter

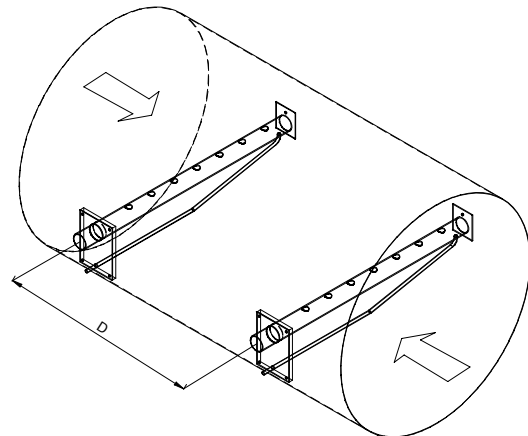

D = Humidification distance

EXPRESSPACK

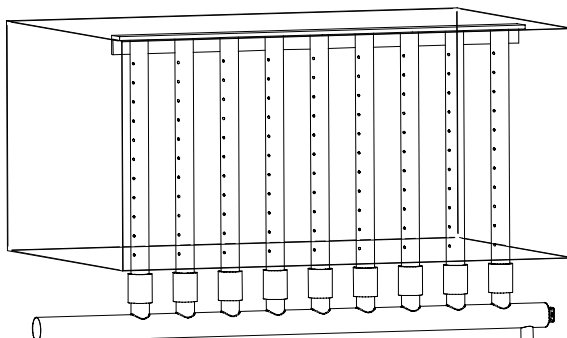

The Armstrong ExpressPack is a bespoke steam humidification system made to suit your configuration and ready to install in a ventilation duct.

It permits to have vapor trails (evaporation distance) as short as 600 mm. For further reference, please contact **devatec** or their authorized agent.

STEAM OUTPUT

1. We would recommend to use the steam hose from Devatec supply .
NB : when the humidifier is started up for the first time, a smell of burning may be smelt especially when brand new hoses are installed. This is normal and will eventually dispel.
2. Steam hose selection :

Model ELMC	1 SM CYL	1 LG CYL	2 CYL	3 CYL
Nb of steam outlets	1	1	2	3
Steam outlet Ø	Ø 25mm	Ø 40mm	Ø 40mm	Ø 40mm

- SM CYL = small cylinder, LG CYL = large cylinder

3. The ELMC humidifier can be used with pressure ducts (P) having the following characteristics :

- If P is inferior to 150mm CE (Water column) i.e. 1470Pa.
- If P is between 150mm CE et 300mm CE, our optional filling cup platform must be used



4. Please adhere to the recommendations given underneath for the installation of the steam hose according to one of the shown examples, the most suited to your installation. A set of hose clamps are supplied for ensuring a correct installation.

The humidifier should be located within 3 m. of the steam distribution pipe. If the distance is superior to 3 m., insulated steel or copper pipe of a slightly larger diameter must be used.

Example a

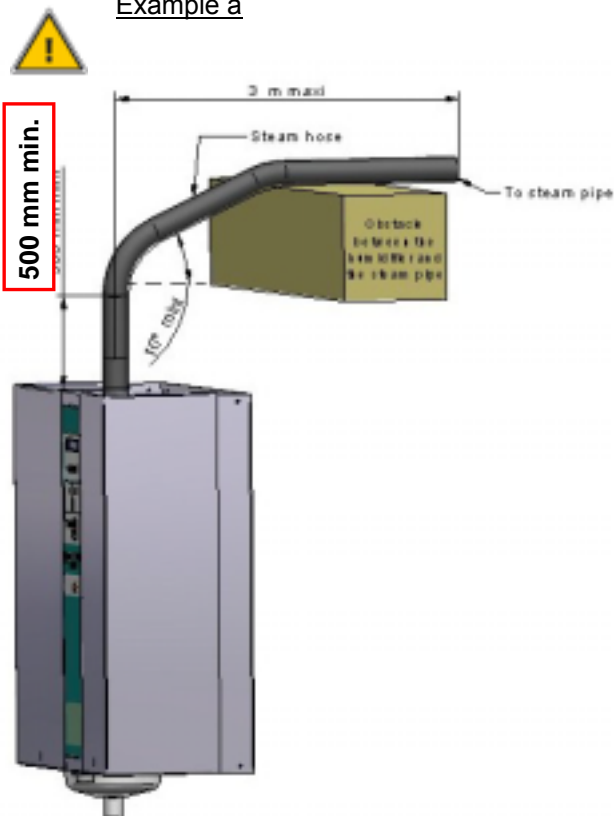

Radius of bend for steam hose :

- Ø 25 mm hose = 250 mm minimal radius
- Ø 40 mm hose = 400 mm minimal radius



Example b

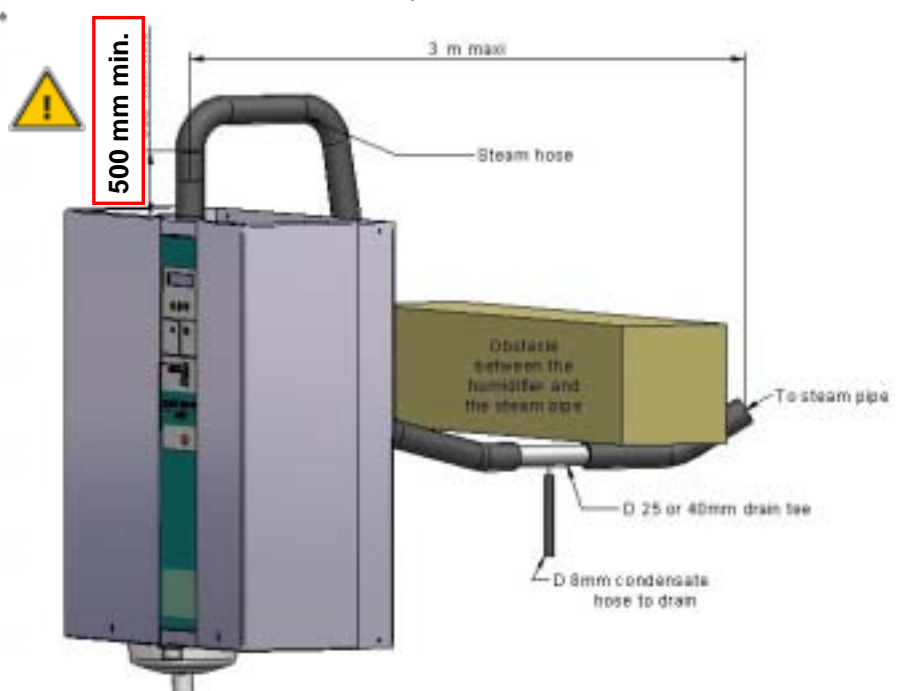

Room ventilation unit

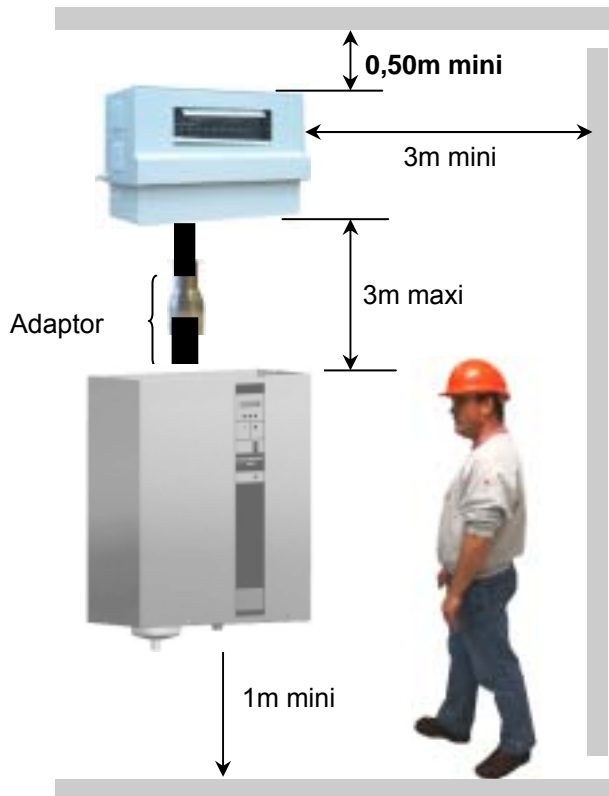

Three ventilation packs permit the use of the humidifier in direct in-space applications where there is no ductworks.

The CV2 and EHFIII ventilation packs cannot be set on the top of the humidifier (see after attached pictures). The distance between the humidifier and the ventilation pack(s) should not exceed 3 m.

The connection of the steam hose between the humidifier and the ventilation packs is made by an adaptor for units ranging from 20 kg up :

- CV2 = Ø 40/25mm adaptor
- EHF3 = Ø 40/50mm adaptor

The connection of the Ø 25 mm steam hose to the CVMC1 ventilation unit doesn't require any adaptor.

When in combination with the ELMC 40 or the ELMC 60, two EHF3 ventilation packs should be used equally distant (X). ($X_1=X_2$)

The electrical connection of the ventilation packs to the humidifier is via terminal block 3 & 4 on the DIN rail.

As far as the EHF-3 is concerned, please revert to the recommendations given on the EHF-3 information sheet. Never connect the EHF-3 unit on the terminals 3 & 4 of the humidifier when a 100VA transformer is installed inside the ElectroVap MC2.

Allow a 3 m. distance ahead to the ventilation pack for a free diffusion of steam.

Overall dimensions of room ventilation units

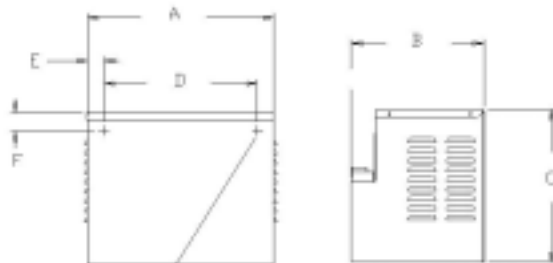

Installation by 2 screws

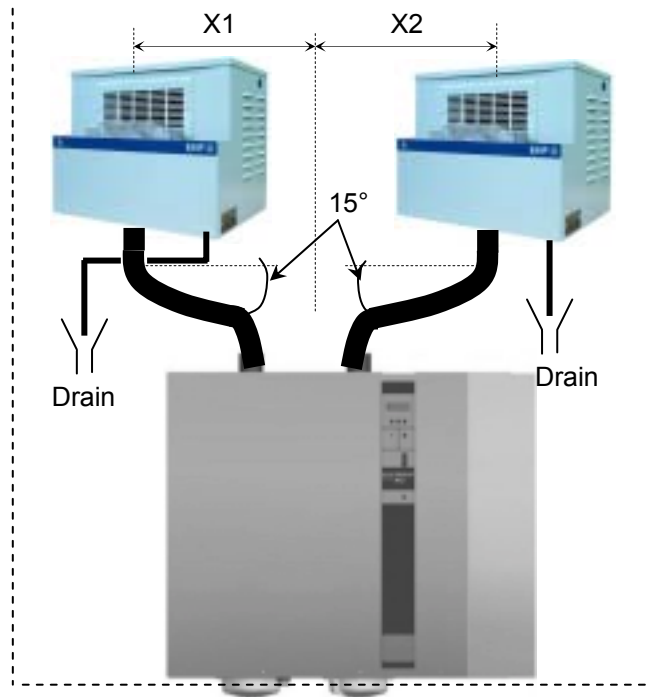

	A	B	C	D	E	F	Weight Kg	dB	Kg/h maxi output	m3/h	Compatible with
CVMC1	400mm	195mm	165mm	330mm	35mm	35mm	4.6	35	10	150	ELMC2 5 to 10
CV2	520mm	260mm	350mm	360mm	80mm	35mm	12	38	20	300	ELMC2 15-2 & 20
EHFIII	495mm	356mm	406mm	406mm	44mm	51mm	15	48	55	780	ELMC2 30 to 50

CONDENSATE DRAINING

Pict. 1

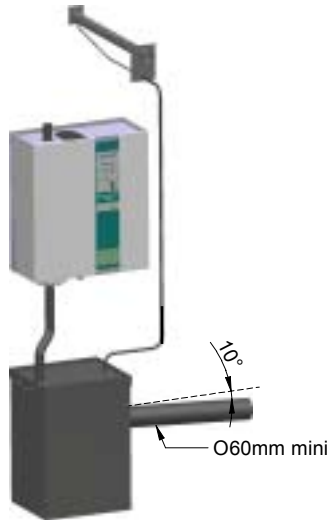

Pict. 2

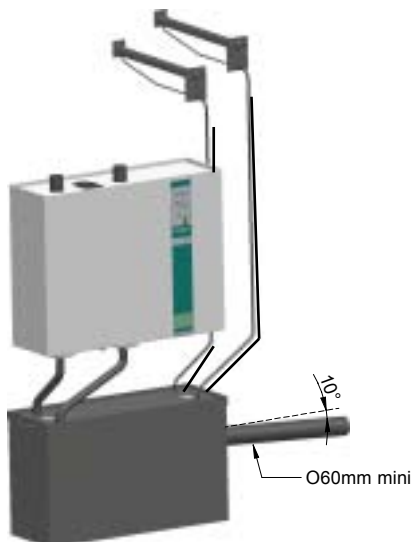

Pict. 3

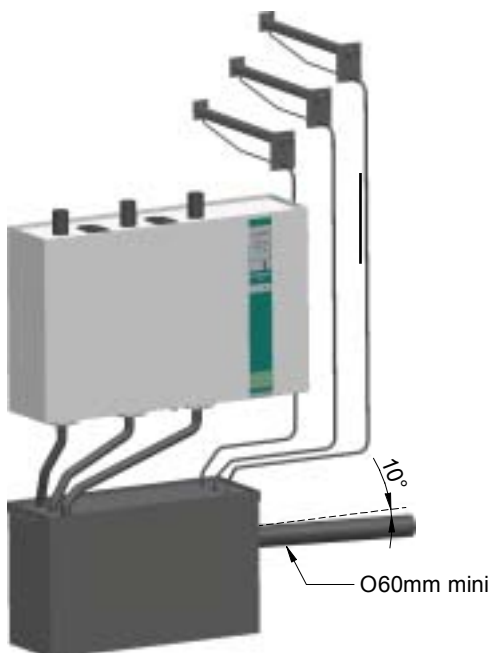

Pict. 4

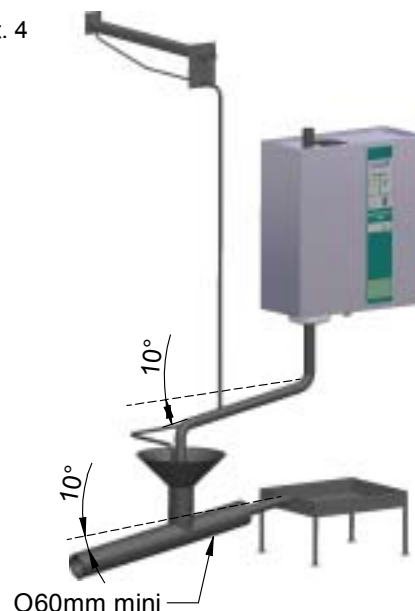

The following drawings show the water draining connections that should be made.

- The devatec supplied steam hose should be used :
 - ELMC 1 cylinder** : 1m Ø25mm hose with 1 hose clamp (supplied).
 - ELMC 2 cylinders** : 1m + 1.2m Ø25mm hose with 2 clamps (supplied).
 - ELMC 3 cylinders** : 1m + 1.2m + 1.8m Ø25mm hose with 3 clamps (supplied).
 These hoses are designed to be connected to the draining system. Regular replacement is recommended.
- If rigid piping is used, it must be heat (100°C) and pressure resistant PVC material and have a 60 mm wide diameter.
- The discharge hose must be free from any obstacle. It is recommended that each steam cylinder has its own drain pipe and tank arrangement. 
- Use water tanks with a lid that has water collecting facilities (s.a. drawings 1, 2 and 3).
- A funnel can also be used (s.a. pict. 4), but it should be offset from the underside of the unit to prevent any steam and/or condensation from getting into the cabinet. The installation of a siphon (as per the draining hose) is recommended and arrangements for holding water spilling should also be made.
- CAUTION** : keep a minimum pitch of 10° for both the draining hose of the humidifier and for general drain pipe (s.a. pictures 1, 2, 3 and 4).





RECOMMENDATION:



All works concerned with the electrical installation must be carried out by skilled and qualified personnel (eg electrician with appropriate training). The customer is responsible for ensuring their suitability. Please observe local regulations concerning the provision of electrical installations.



Check all electrical terminal screws at commissioning, after 50 hours operation and at every service thereafter.



Take care : the ELMC electronic components are very sensitive to electrostatic shocks. Appropriate steps must be taken before any operation.



ELECTROVAP MC2

Installation - Step 5

ELECTRICAL TABLES

ELMC steam humidifier in 2 X 220V - 50/60 Hz

ELMC	Steam production (KG/Steam)	In (A)	Imaxi (A)	Pmaxi (KW)	Cylinder size	Steam diameter	Torroidal Transformer wiring
5	5.00	17	18.4	4.05	Small	25	Straight through
10	10.00	34	36	7.92	25 large	25	Split

ELMC steam humidifier in 2 X 230V - 50/60 Hz

ELMC	Steam production (KG/Steam)	In (A)	Imaxi (A)	Pmaxi (KW)	Cylinder size	Steam diameter	Torroidal transformer
5	5.00	16.3	17.6	4,05	Small	25	Straight through
10	10.00	32.7	34.8	8,00	25 large	25	Split



ALL WORKS CONCERNED WITH ELECTRICAL INSTALLATION MUST BE CARRIED OUT BY A SKILLED AND QUALIFIED PERSONNEL



ELECTROVAP MC2

Installation - Step 5

ELMC steam humidifier in 3 X 208V - 50/60 Hz

ELMC	Steam production (KG/Steam)	In (A)	Imaxi (A)	Pmaxi (KW)	Cylinder size	Steam diameter	Torroidal transformer
5	5	9,6	10,5	4,13	Small	25	Straight through
8	8	15,3	16,5	6,49	Small	25	Straight through
10	10	19,1	20,5	8,07	Small	25	Straight through
15-2	15	28,7	30,6	12,04	40 large	40	Split
20	20	38,2	40,6	15,98	40 large	40	Split
25	25	47,8	50,7	19,95	40 large	40	Split
30	32	62,9	66,6	26,21	2 x 40 large	40	Split
40	40	76,5	81	31,84	2 x 40 large	40	Split
50	50	95,6	101,1	39,75	3 x 40 large	40	Split
60	60	114,7	121,2	47,66	3 x 40 large	40	Split

ELMC steam humidifier in 3 X 220V - 50/60 Hz

ELMC	Steam production (KG/Steam)	In (A)	Imaxi (A)	Pmaxi (KW)	Cylinder size	Steam diameter	Torroidal transformer
5	5	10	10,9	4,2	Small	25	Straight through
8	8	15,8	17	6,5	Small	25	Straight through
10	10	19,7	21,1	8,1	Small	25	Straight through
15-2	15	29,6	31,6	12	40 large	40	Split
20	20	39,4	41,9	16	40 large	40	Split
25	25	49	52	19,8	40 large	40	Split
30	32	64,9	68,7	26,2	2 x 40 large	40	Split
40	40	78,9	83,5	31,8	2 x 40 large	40	Split
50	50	99	104,6	39,9	3 x 40 large	40	Split
60	60	119	125,7	47,9	3x 40 large	40	Split
70	70	138	145,7	55,5	3 x 40 large	40	Split



ALL WORKS CONCERNED WITH ELECTRICAL INSTALLATION MUST BE CARRIED OUT BY A SKILLED AND QUALIFIED PERSONNEL



ELECTROVAP MC2

Installation - Step 5

ELMC steam humidifier in 3 X 230V - 50/60 Hz

ELMC	Steam production (KG/Steam)	In (A)	Imaxi (A)	Pmaxi (KW)	Cylinder size	Steam diameter	Torroidal transformer
5	5	9,6	10,5	4,13	Small	25	Straight through
8	8	15,3	16,5	6,49	Small	25	Straight through
10	10	19,1	20,5	8,07	Small	25	Straight through
15-2	15	28,7	30,6	12,04	40 large	40	Split
20	20	38,2	40,6	15,98	40 large	40	Split
25	25	47,8	50,7	19,95	40 large	40	Split
30	32	62,9	66,6	26,21	2 x 40 large	40	Split
40	40	76,5	81	31,84	2 x 40 large	40	Split
50	50	95,6	101,1	39,75	3 x 40 large	40	Split
60	60	114,7	121,2	47,66	3 x 40 large	40	Split
70	70	133,8	141,3	55,57	3 x 40 large	40	Split

ELMC steam humidifier in 3 X 380V - 50/60 Hz

ELMC	Steam production (KG/Steam)	In (A)	Imaxi (A)	Pmaxi (KW)	Cylinder size	Steam diameter	Torroidal transformer wiring
5	5	5,7	6,4	4,2	Small	25	Loop
8	8	9,1	10	6,6	Small	25	Straight through
10	10	11,4	12,4	8,2	Small	25	Straight through
15-2	15	17,1	18,4	12,1	Small	25	Straight through
20	20	22,8	24,5	16,1	40 large	40	Straight through
30	30	34,3	36,5	24	40 large	40	Split
30 HC	33	38	40,4	26,26	40 large	40	Split
40	40	45,7	48,5	31,9	2 x 40 large	40	Straight through
50	50	57,1	60,5	39,8	2 x 40 large	40	Split
60	60	68,5	72,6	47,8	2 x 40 large	40	Split
60 HC	66	76	80,4	52,26	2 x 40 large	40	Split
90	90	102,8	108,7	71,5	3 x 40 large	40	Split
90 HC	99	114	120,4	78,26	3 x 40 large	40	Split



ALL WORKS CONCERNED WITH ELECTRICAL INSTALLATION MUST BE CARRIED OUT BY A SKILLED AND QUALIFIED PERSONNEL



ELECTROVAP MC2

Installation - Step 5

ELMC steam humidifier in 3 X 400V - 50/60 Hz

ELMC	Steam production (KG/Steam)	In (A)	Imaxi (A)	Pmaxi (KW)	Cylinder size	Steam diameter	Torroidal transformer
5	5	5,5	6,2	4,24	Small	25	Loop
8	8	8,8	9,7	6,63	Small	25	Straight through
10	10	11	12	8,21	Small	25	Straight through
15-2	15	16,5	17,8	12,18	Small	25	Straight through
20	20	22	23,5	16,07	40 large	40	Straight through
30	30	33	35,1	24,01	40 large	40	Split
30 HC	33	36,3	38,6	26,42	40 large	40	Split
40	40	44	46,7	31,94	2 x 40 large	40	Straight through
50	50	55	58,3	39,88	2 x 40 large	40	Split
60	60	66	69,8	47,74	2 x 40 large	40	Split
60 HC	66	72,6	76,8	52,56	2 x 40 large	40	Split
90	90	98,9	104,6	71,55	3 x 40 large	40	Split
90 HC	99	108,9	115,1	78,71	3 x 40 large	40	Split

ELMC steam humidifier in 3 X 415V - 50/60 Hz

ELMC	Steam production (KG/Steam)	In (A)	Imaxi (A)	Pmaxi (KW)	Cylinder size	Steam diameter	Torroidal transformer wiring
5	5	5,3	6	4,26	Small	25	Loop
8	8	8,5	9,3	6,60	Small	25	Straight through
10	10	10,6	11,6	8,23	Small	25	Straight through
15-2	15	15,9	17,1	12,14	Small	25	Straight through
20	20	21,2	22,7	16,11	40 large	40	Straight through
30	30	31,8	33,9	24,06	40 large	40	Split
30 HC	33	35	37,3	26,44	40 large	40	Split
40	40	42,4	45	31,93	2 x 40 large	40	Straight through
50	50	53	56,2	39,88	2 x 40 large	40	Split
60	60	63,6	67,3	47,76	2 x 40 large	40	Split
60 HC	66	70	74,1	52,59	2 x 40 large	40	Split
90	90	95,4	100,8	71,53	3 x 40 large	40	Split
90 HC	99	105	111	78,74	3 x 40 large	40	Split

 ALL WORKS CONCERNED WITH ELECTRICAL INSTALLATION MUST BE CARRIED OUT BY A SKILLED AND QUALIFIED PERSONNEL



ELECTROVAP MC2

Installation - Step 5

ELMC steam humidifier in 3 X 480V - 50/60 Hz

ELMC	Steam production (KG/Steam)	In (A)	Imaxi (A)	Pmaxi (KW)	Cylinder size	Steam diameter	Torroidal transformer wiring
5	5	4,6	5,2	4,25	Small	25	Loop
8	8	7,3	8	6,58	Small	25	Straight through
10	10	9,2	10,1	8,27	Small	25	Straight through
15-2	15	13,7	14,9	12,22	Small	25	Straight through
20	20	18,3	19,6	16,09	40 large	40	Straight through
30	30	27,5	29,3	24,06	40 large	40	Split
30 HC	33	30	32	26,25	40 large	40	Split
40	40	36,6	38,9	31,95	2 x 40 large	40	Straight through
50	50	45,8	48,5	39,85	2 x 40 large	40	Split
60	60	55	57,7	47,37	2 x 40 large	40	Split
60 HC	65	60	63,6	52,18	2 x 40 large	40	Split
90	90	82,4	87	71,43	3 x 40 large	40	Split
90 HC	99	91	96,2	78,98	3 x 40 large	40	Split

ELMC steam humidifier in 3 X 575V - 50/60 Hz

ELMC	Steam production (KG/Steam)	In (A)	Imaxi (A)	Pmaxi (KW)	Cylinder size	Steam diameter	Torroidal transformer wiring
5	5	3,8	4,4	4,33	Small	25	Loop
8	8	6,1	6,8	6,69	Small	25	Straight through
10	10	7,6	8,4	8,26	Small	25	Straight through
15-2	15	11,5	12,5	12,29	Small	25	Straight through
20	20	15,3	16,5	16,22	40 large	40	Straight through
30	30	22,9	24,6	24,19	40 large	40	Split
30 HC	33	25	26,7	26,27	40 large	40	Split
40	40	30,6	32,6	32,05	2 x 40 large	40	Straight through
50	50	38,2	40,7	40,02	2 x 40 large	40	Split
60	60	45,9	48,7	47,88	2 x 40 large	40	Split
60 HC	65	50	53	52,16	2 x 40 large	40	Split
90	90	68,8	72,9	71,68	3 x 40 large	40	Split
90 HC	99	76	80,4	79,08	3 x 40 large	40	Split



ALL WORKS CONCERNED WITH ELECTRICAL INSTALLATION MUST BE CARRIED OUT BY A SKILLED AND QUALIFIED PERSONNEL



ELECTROVAP MC2

Installation - Step 5

ELMC steam humidifier in 3 X 600V - 50/60 Hz

ELMC	Steam production (KG/Steam)	In (A)	Imaxi (A)	Pmaxi (KW)	Cylinder size	Steam diameter	Torroidal transformer wiring
5	5	3,7	4,3	4,41	Small	25	Loop
8	8	5,9	6,6	6,77	Small	25	Straight through
10	10	7,3	8,1	8,31	Small	25	Straight through
15-2	15	11	12	12,31	Small	25	Straight through
20	20	14,7	15,8	16,21	Large 40	40	Straight through
30	30	22	23,5	24,11	Large 40	40	Split
30 HC	33	24	25,7	26,34	Large 40	40	Split
40	40	29,3	31,3	32,11	2 x Large 40	40	Straight through
50	50	36,6	39	40,01	2 x Large 40	40	Split
60	60	44	46,7	47,91	2 x Large 40	40	Split
60 HC	65	48	50,9	52,26	2 x Large 40	40	Split
90	90	66	69,8	71,61	3 x Large 40	40	Split
90 HC	98	72	76,2	78,19	3 x Large 40	40	Split

ELMC steam humidifier in 3 X 690V - 50/60 Hz

ELMC	Steam production (KG/Steam)	In (A)	Imaxi (A)	Pmaxi (KW)	Cylinder size	Steam diameter	Torroidal transformer wiring
5	5	3,2	3,8	4,48	Small	25	Loop
8	8	5,1	5,8	6,84	Small	25	Straight through
10	10	6,4	7,1	8,38	Small	25	Straight through
15-2	15	9,6	10,5	12,39	Small	25	Straight through
20	20	12,7	13,8	16,28	Large 40	40	Straight through
30	30	19,1	20,5	24,19	Large 40	40	Split
30 HC	33	35,32	21	22,5	Large 40	40	Split
40	40	25,5	27,2	32,09	2 x Large 40	40	Straight through
50	50	31,9	33,9	40	2 x Large 40	40	Split
60	60	28,2	40,7	48,02	2 x Large 40	40	Split
60 HC	66	42	44,6	52,65	2 x Large 40	40	Split
90	90	57,4	60,8	71,74	3 x Large 40	40	Split
90 HC	99	63	66,7	78,74	3 x Large 40	40	Split



ALL WORKS CONCERNED WITH ELECTRICAL INSTALLATION MUST BE CARRIED OUT BY A SKILLED AND QUALIFIED PERSONNEL

ELECTRICAL CONNECTIONS



All works concerned with electrical installation must be carried out by a skilled and qualified personnel.
Make sure that all incoming power supplies are isolated before installation and maintenance of the ElectroVap MC2 humidifier.

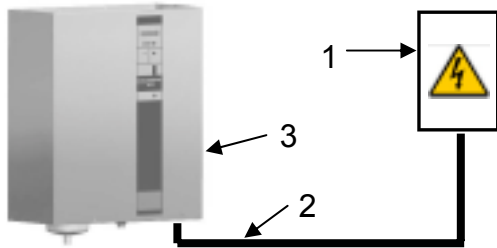

- 1 - Power supply isolator and MCB
- 2 - Power supply cable
- 3 - Electrical compartment

WARNING :

Failure to fit an electrical power isolator and MCB as part of the electrical installation significantly increases the risk of electric shock, which can be fatal.

A) U= 2 x 220-230V

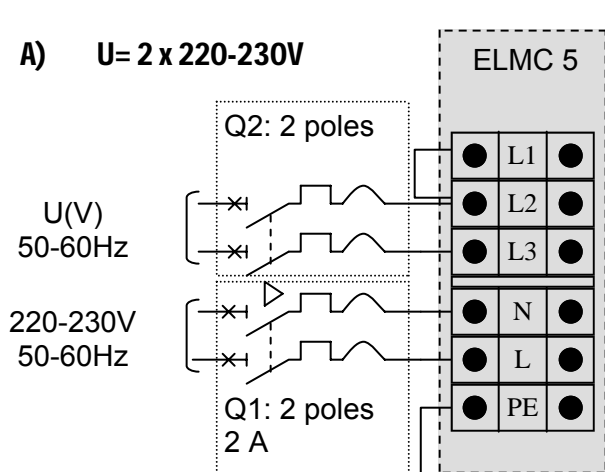

Q1 and Q2: MCB and electrical power isolation

B) U= 3 X 380-400 V

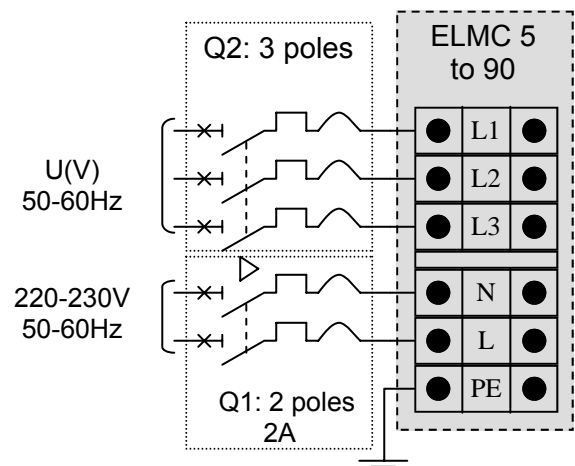

C) 3 phases + neutral: U = 3 x 380-400 V + 1 x 220-230V

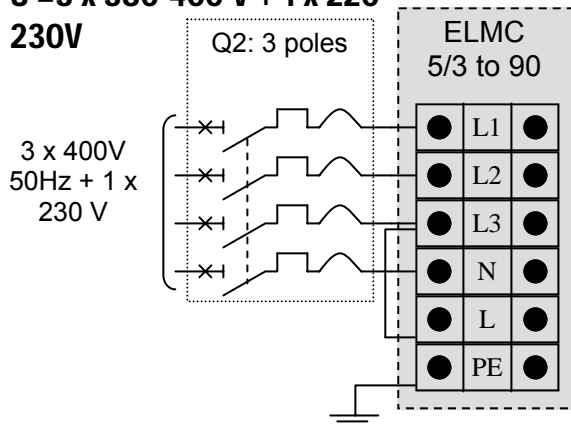

The symbol Δ between Q1 & Q2 means that these MCB are coupled. The power MCB Q2 and control MCB Q1 are mechanically linked together. So if a fault is detected, the power and the control circuits are switched off and there is no voltage on the unit. The unit is really off voltage.

D) 3 phases without neutral: 3 x 380-400 V

In this case, a transformer (option) must be installed (See technical notice page n°31)

Nota: for connecting optional ventilation pack or humidistat, please refer to pages n°21 & 37 of this manual.



Failure to observe manufacturer's installation recommendations will invalidate the manufacturer's warranty.



ALL WORKS CONCERNED WITH ELECTRICAL INSTALLATION MUST BE CARRIED OUT BY A SKILLED AND QUALIFIED PERSONNEL

TRANSFORMER (OPTION)

The ELMC 5 to 90 humidifiers are electrically supplied in 3x400v + G + N. In case a neutral line is not available, this can however be easily substituted by the use of our optional transformer preventing the installation of a specific neutral line.

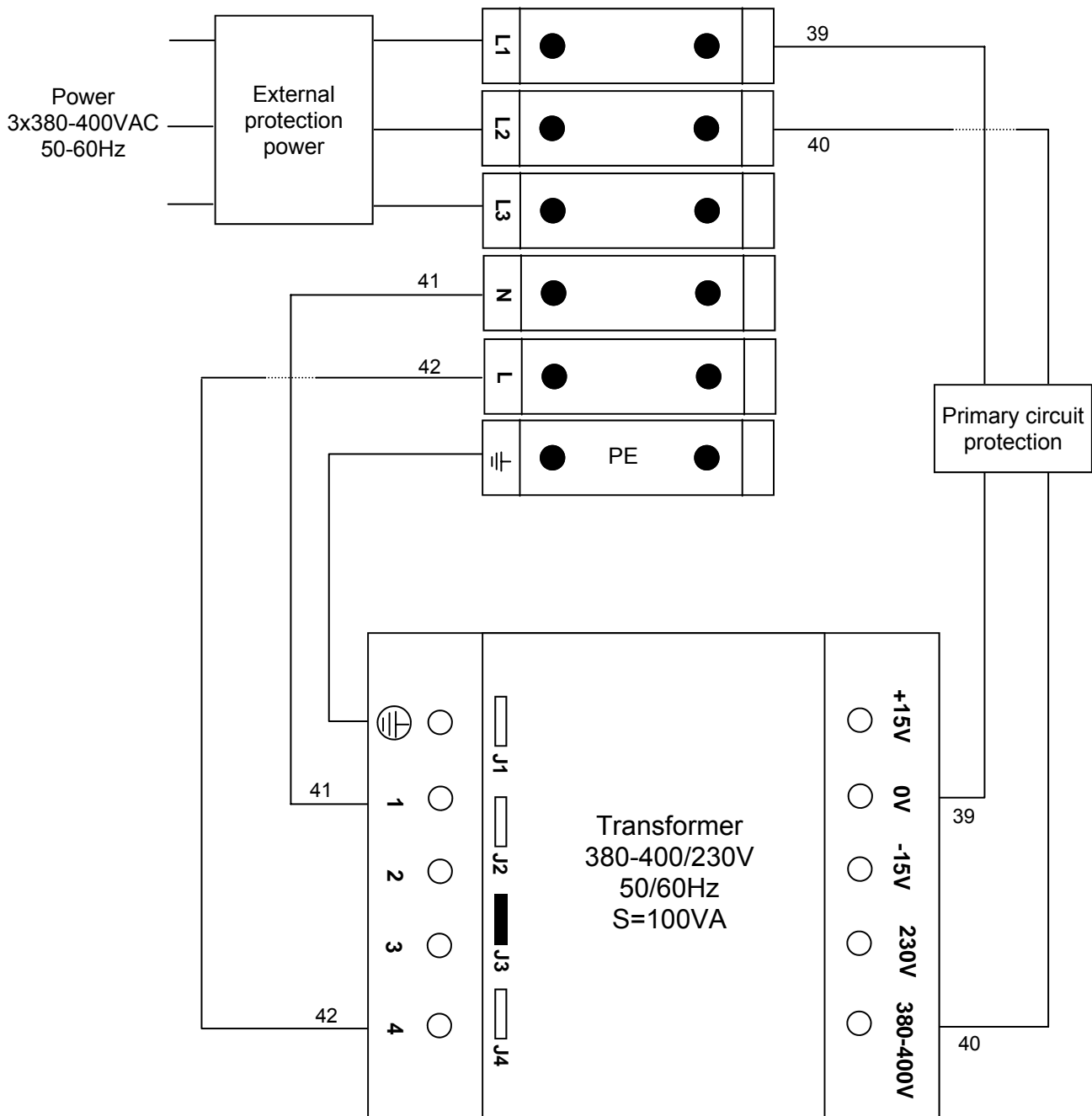

ALL WORKS CONCERNED WITH ELECTRICAL INSTALLATION MUST BE CARRIED OUT BY A SKILLED AND QUALIFIED PERSONNEL



The wiring of the optional equipment described under must be made with 0.75 mm² flexible cable.

REMOTE INFORMATION BOARD (OPTION)



Platine Réf: 500400/03

Contact can be modified in NO or NF by wiring as per the following schemes (ex: wiring on 30 & 31 = NO contact).

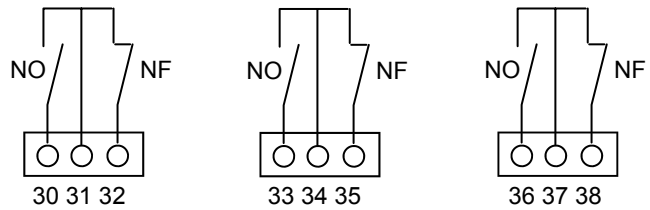

- X22 connector (36-37-38): Remote steam production dry contact.
- X21 connector (33-34-35): Remote general fault dry contact
- X20 connector (30-31-32): Remote cylinder maintenance dry contact

RS485 OR RS422 OR RS232 CIRCUIT BOARD (OPTION)



Main board Réf: 500800/01

SPECIFICATIONS

RS485 : 2 wires half duplex (+GND) Maximum length : 1200 m.
RS422 : 4 wires half duplex (+GND) On demand—Max length 1200 m

RS232 : 2 wires half duplex (+GND) On demand—Max length : 20 m.
Bias : 620 Ohms pull-up and pull-down (jumper selectable)
Termination : 120 Ohm (jumper selectable)

Protocol : JBUS or MODBUS (asynchronous of 8 bit data, no parity bit, 1 bit stop, CRC)

Speed data : 1200, 2400, 4800, 9600 bauds

Mounting : on the DIN rail
Size : 95 x 50 mm



ALL WORKS CONCERNED WITH ELECTRICAL INSTALLATION MUST BE CARRIED OUT BY A SKILLED AND QUALIFIED PERSONNEL

ELMC 5 WIRING SCHEME (2 x 220-230 V)

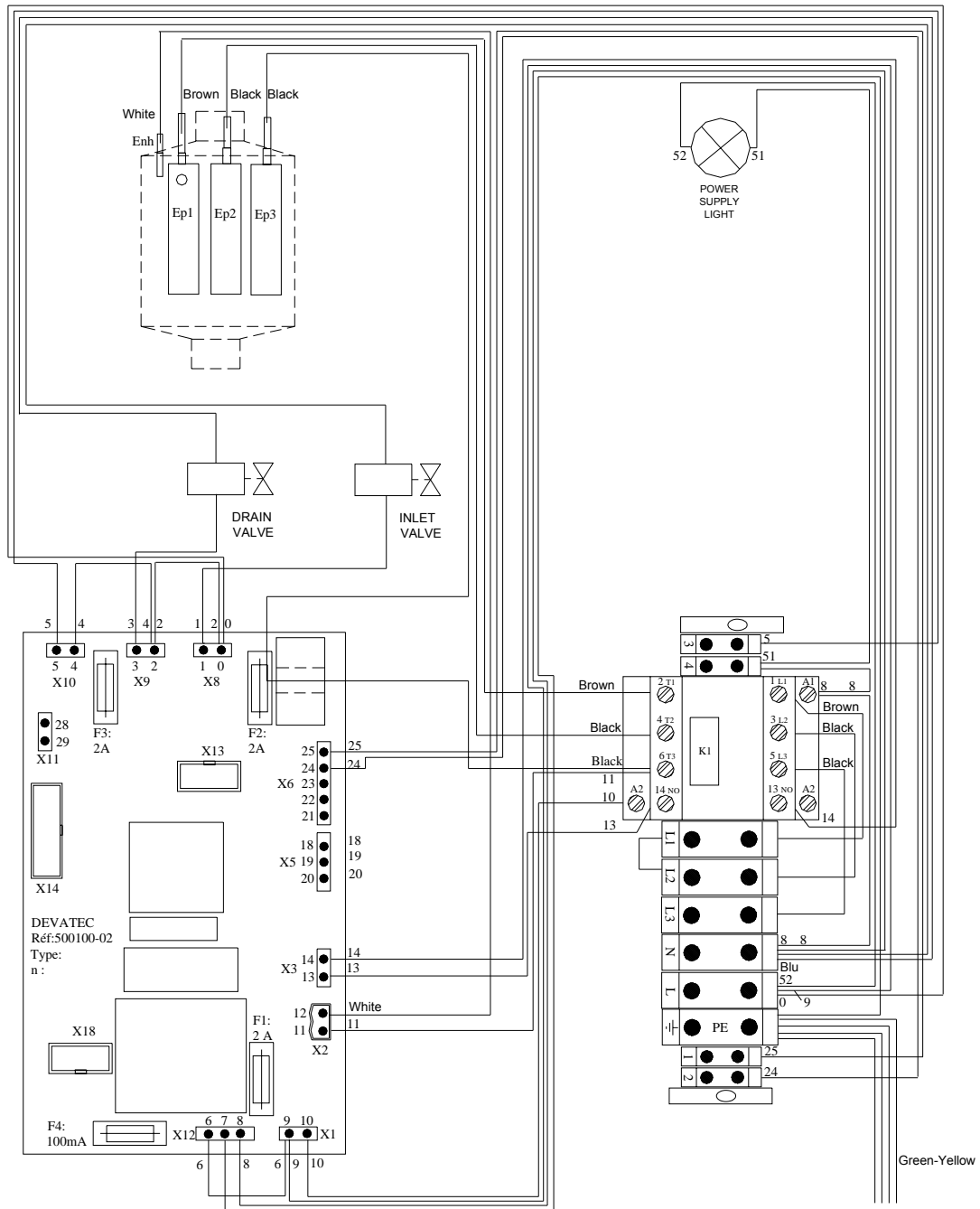

Mark	Intensity	Fuse function
F1	2A	Protection of the power contactor coil
F2	2A	Protection of the inlet valve coil
F3	2A	Protection of the drain valve coil
F4	100mA	Protection of the electronic boards



ALL WORKS CONCERNED WITH ELECTRICAL INSTALLATION MUST BE CARRIED OUT BY A SKILLED AND QUALIFIED PERSONNEL



ELECTROVAP MC2

Installation - Step 5

ELMC 5 to 25 WIRING SCHEME - 3 x 208 - 230 V

ELMC 5 to 30 WIRING SCHEME - 3 X 380 to 690 V

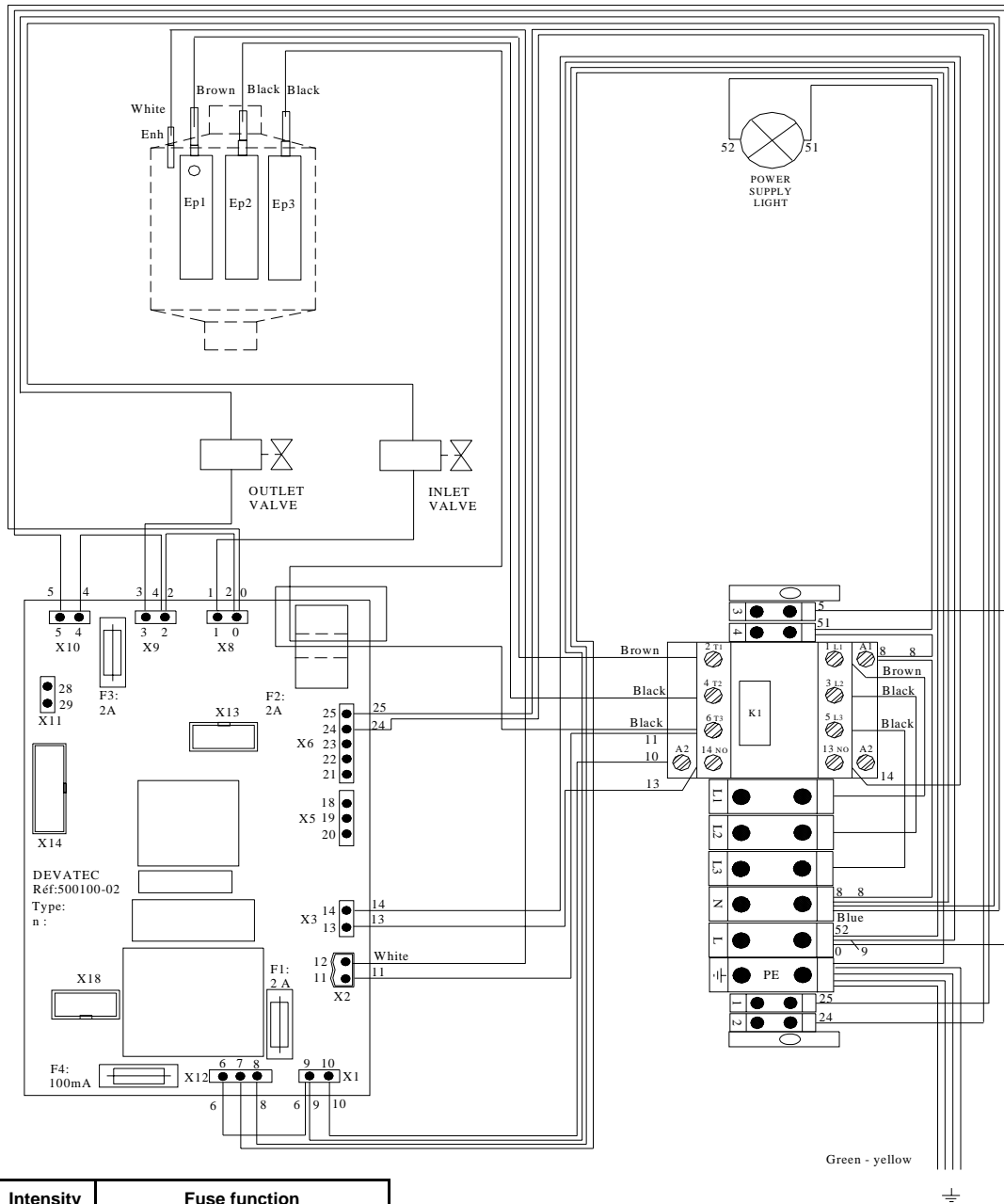

Mark	Intensity	Fuse function
F1	2A	Protection of the power contactor coil
F2	2A	Protection of the inlet valve coil
F3	2A	Protection of the drain valve coil
F4	100mA	Protection of the electronic boards



ALL WORKS CONCERNED WITH ELECTRICAL INSTALLATION MUST BE CARRIED OUT BY A SKILLED AND QUALIFIED PERSONNEL



ELECTROVAP MC2

Installation - Step 5

ELMC 30-40 WIRING SCHEME - 3 x 208 to 230 V

ELMC 40 to 60 WIRING SCHEME - 3 x 380 to 690 V

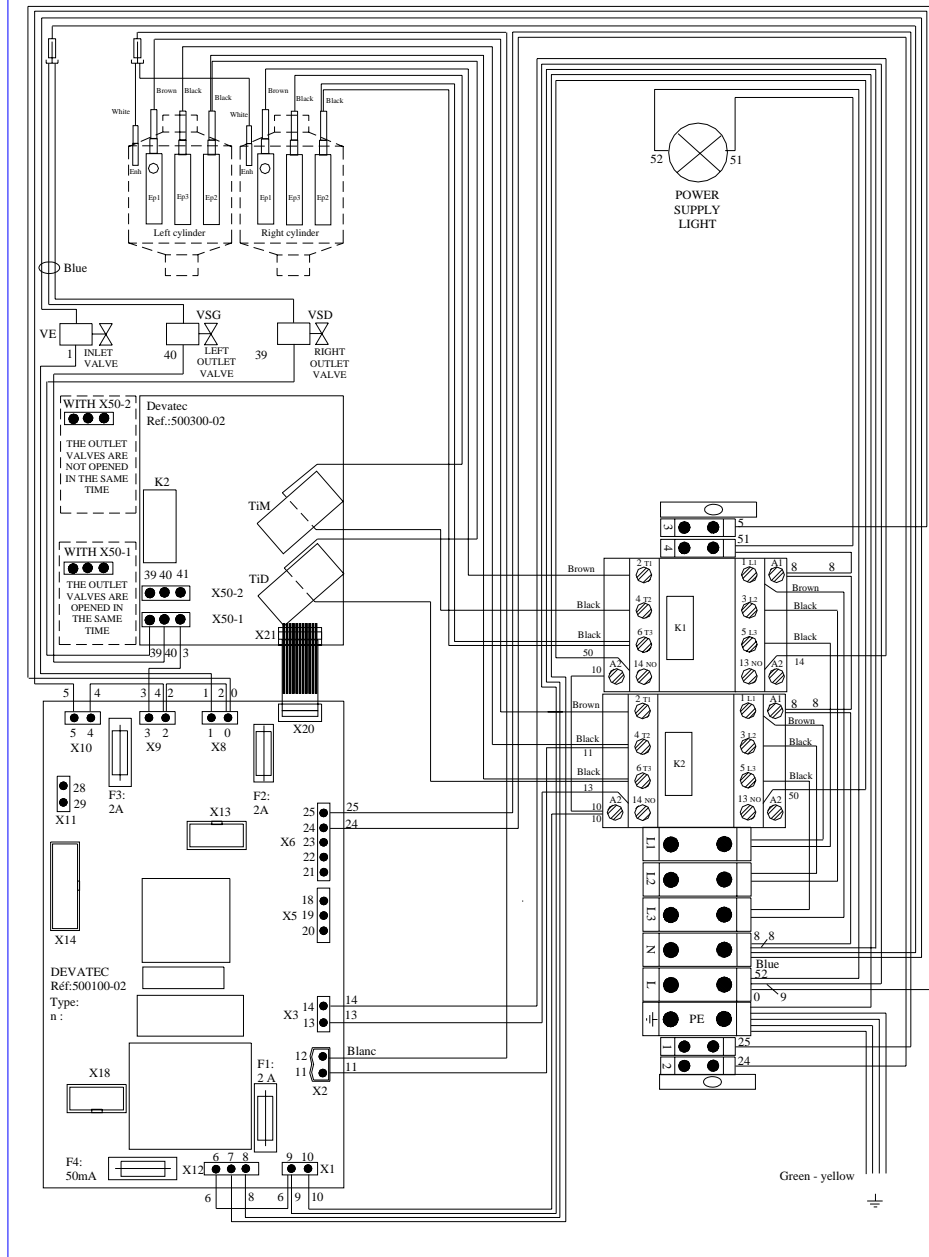

Mark	Intensity	Fuse function
F1	2A	Protection of the power contactor
F2	2A	Protection of the inlet valve coil
F3	2A	Protection of the drain valve coil
F4	100mA	Protection of the electronic boards



ALL WORKS CONCERNED WITH ELECTRICAL INSTALLATION MUST BE CARRIED OUT BY A SKILLED AND QUALIFIED PERSONNEL

ELMC 50-60 WIRING SCHEME - 3 x 208 V ELMC 50 to 70 WIRING SCHEME - 3 x 220-230 V & ELMC 90

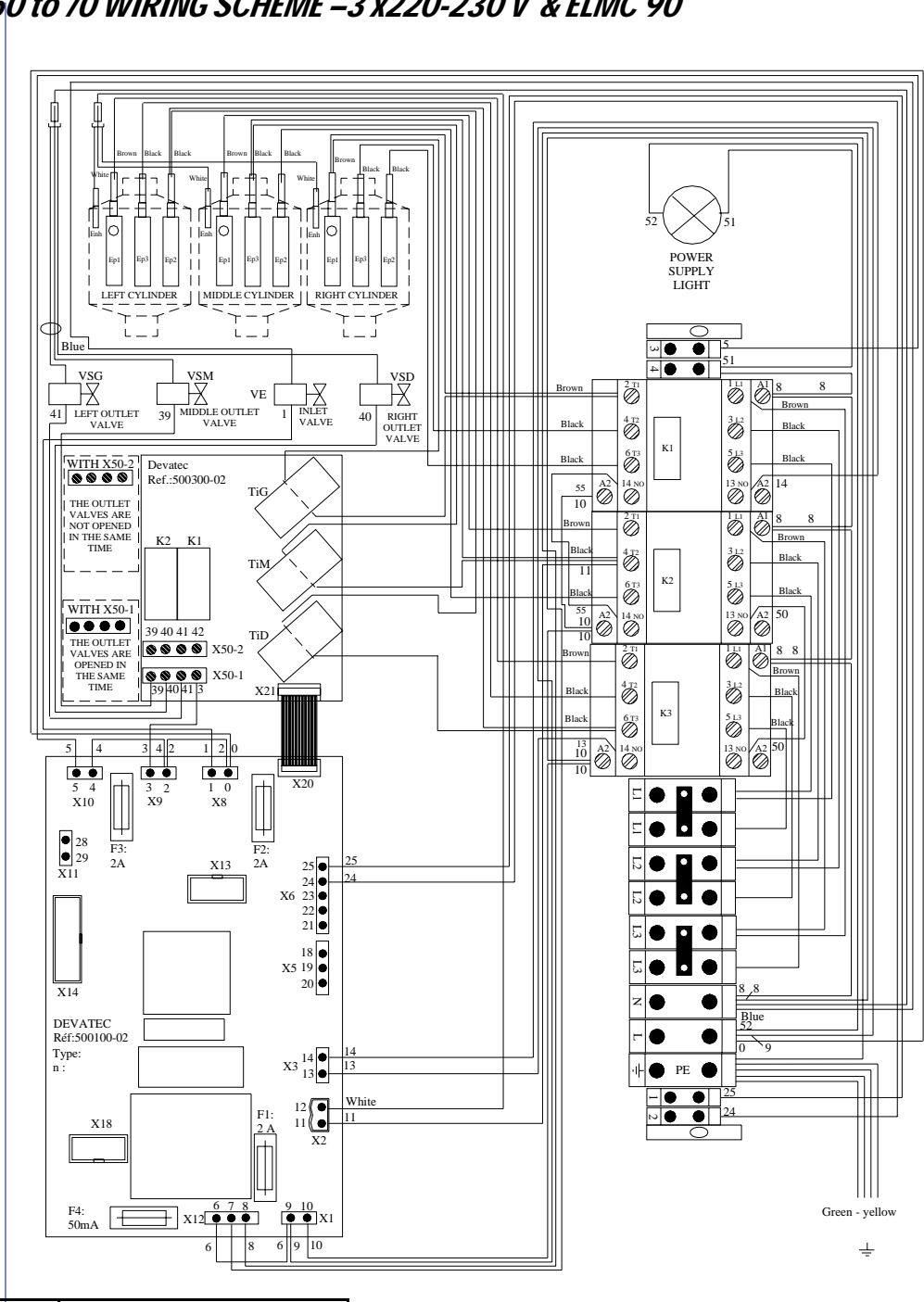

Mark	Intensity	Fuse function
F1	2A	Protection of the power contactor coil
F2	2A	Protection of the inlet valve coil
F3	2A	Protection of the drain valve coil
F4	100mA	Protection of the electronic boards



ALL WORKS CONCERNED WITH ELECTRICAL INSTALLATION MUST BE CARRIED OUT BY A SKILLED AND QUALIFIED PERSONNEL



Use maximum 0.75 mm² flexible cable for the connection of the control signal.

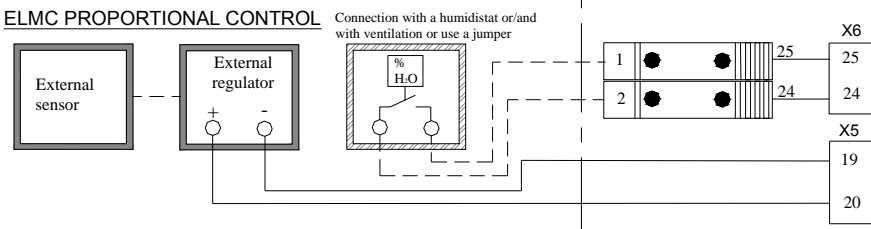
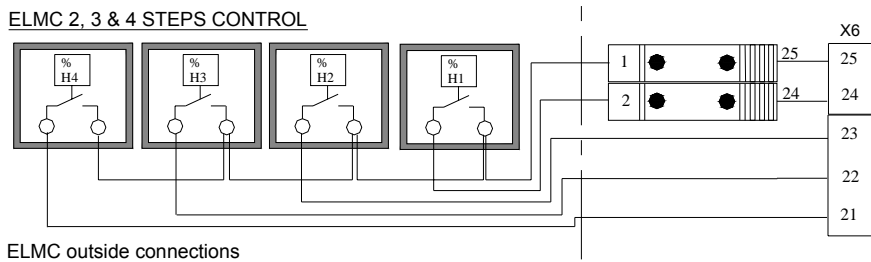
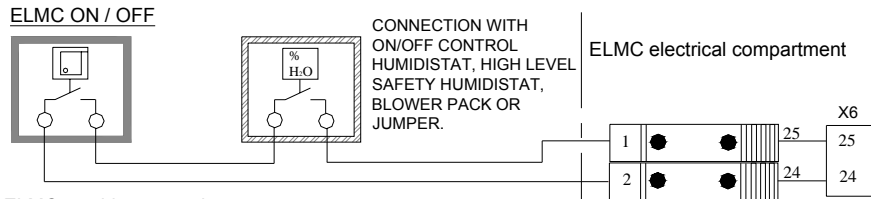

Dip-switch S1 configuration table on main board ref: 500101/03 according to control signal.

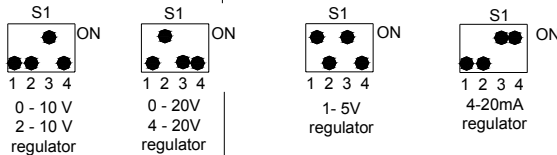

ELMC outside connections

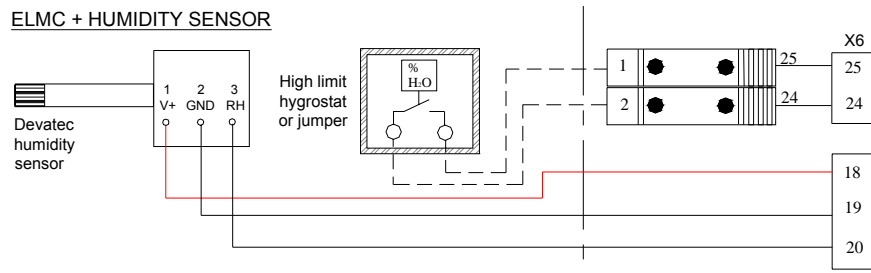

Dip-switch S1 configuration on main board ref: 500101/03 according to control signal.

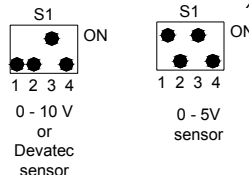

Optional equipment

Equipement not supplied

RJ45 connector: allows a connection to a computer

X5 connector : 18-19-20

X6 connector : 21-22-23-24-25



Main board Réf: 500101/05

S1 Dip Switch :
Allows to select the kind of regulation (see attached scheme for configuration)



ALL WORKS CONCERNED WITH ELECTRICAL INSTALLATION MUST BE CARRIED OUT BY A SKILLED AND QUALIFIED PERSONNEL



Before putting your humidifier in operation, please make sure that your installation be in conformity with the manufacturer's technical specifications.

- Open the water valve of the main water line.
- Switch on the main power supply contactors (voltage and command).
- The power-on light must be illuminated ① .
- Switch on I the I/O (on/off) rocker switch.
- The display will default to show the rate of steam produced. You are in the user information menu.
- As soon as the humidifier is prompted by the regulator, the humidity sensor or the humidistat, the contactor of the DIN rail turns on and the power heating is on (the steam production LED is illuminated) ② .
- 90 seconds after the humidifier is switched on, the inlet valve opens and the cylinder/s is/are flushed with water. The electrode plates then heat the water up and after about 10 minutes (the heating time depends on the model of humidifier and the water conductivity), the humidifier steams up.



ATTENTION

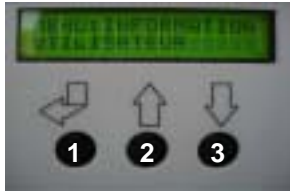

- Any press on button 1 will allow you to shift menu
- Use the up (2) and down (3) keys to scroll menu

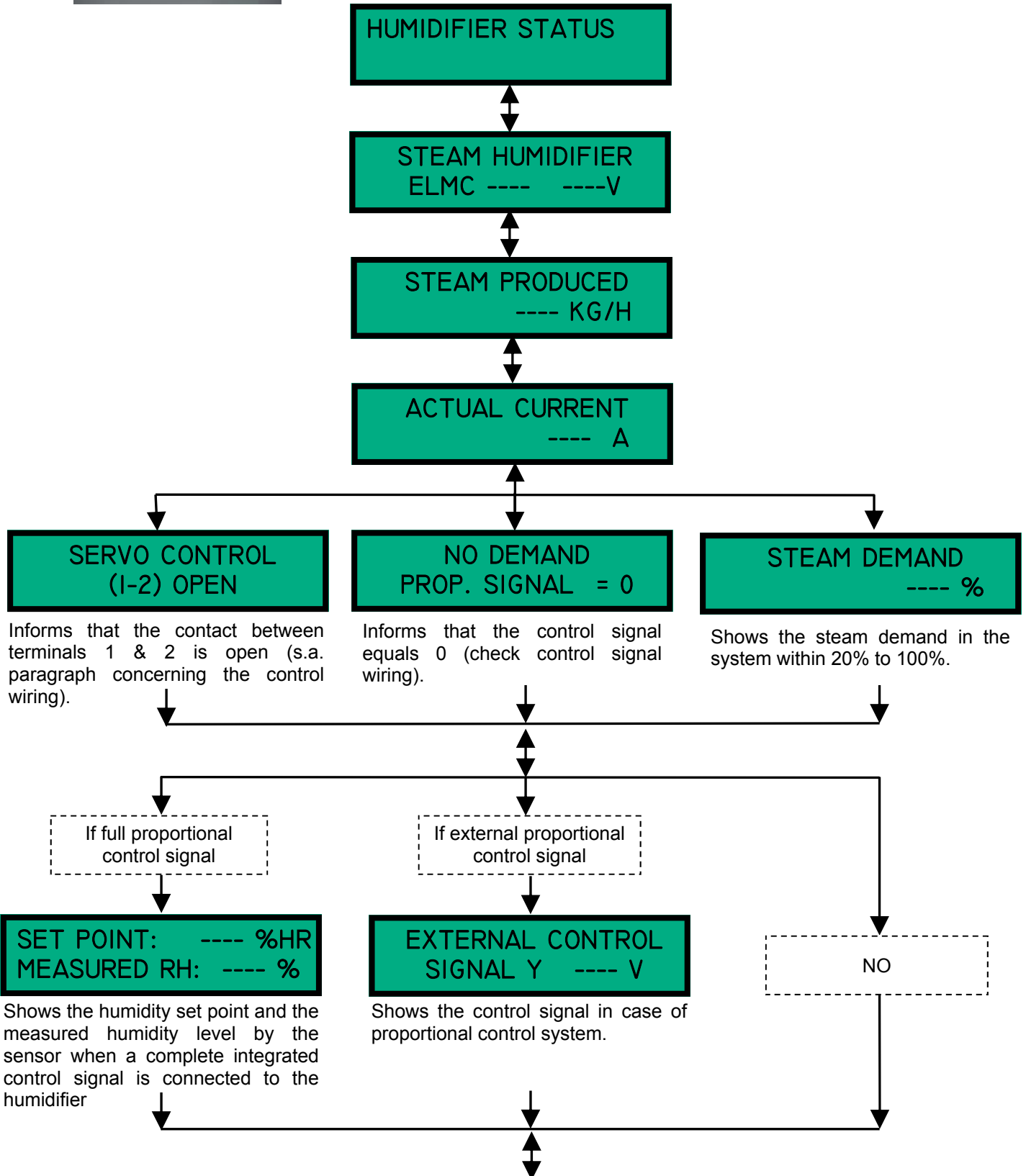

CONTINUED

Draining enabled (factory preset). This allows a draining after a long stop.



This shows the number of kg of steam still available before next service. This is a maintenance planning tool.



This shows the number of hours still available before service. This is a maintenance planning tool.



This shows the working time in hours between two maintenance periods.



This shows the number of working hours of the humidifier between two maintenance periods.



OR

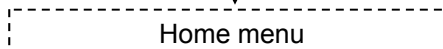

ATTENTION



- Any press on button 1 will allow you to shift menu
- Use the up (2) and down (3) keys to scroll menu

Shows the quantity of steam produced by the humidifier since it has been set up.

Shows the number of hours of operation of the humidifier since it has been set up.

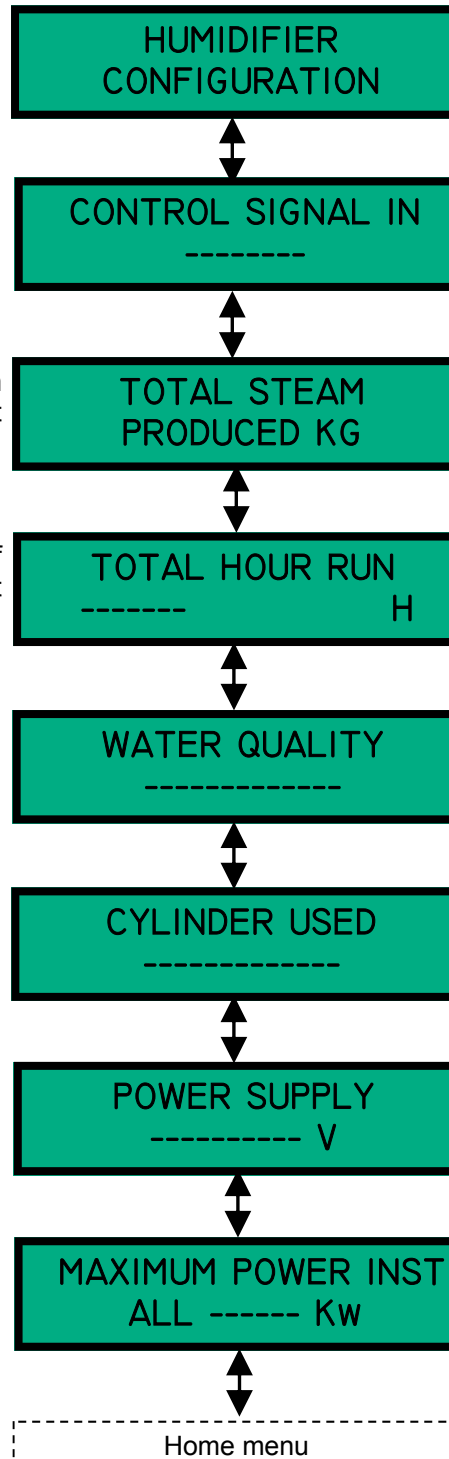



ELECTROVAP MC2

System management

Configuration changing menu

ATTENTION



- A press on button 1 will allow you to shift to sub-menu for changing configuration parameters.
- Then scroll display using the up (2) or down (3) keys.
- The selected parameter will flash and press return key (1) for recording.

With the humidifier switched on, press the ↵ key and the first digit will flash. Press the ↑ (2) key to increase or ↓ (3) key to decrease the first figure to enter of the access code. Press ↵ (1) to confirm. The next digit will start to flash. Repeat for a second and third digit of the access code.

This parameter allows to select the type of the control signal. A humidifier originally supplied in on/off control can be upgraded with an optional control upgrading kit.

This allows to limit the steam production capacity from 100% to 20%

This allows to set the set point of the desired humidity percentage.

This allows to adjust precisely the proportional control signal

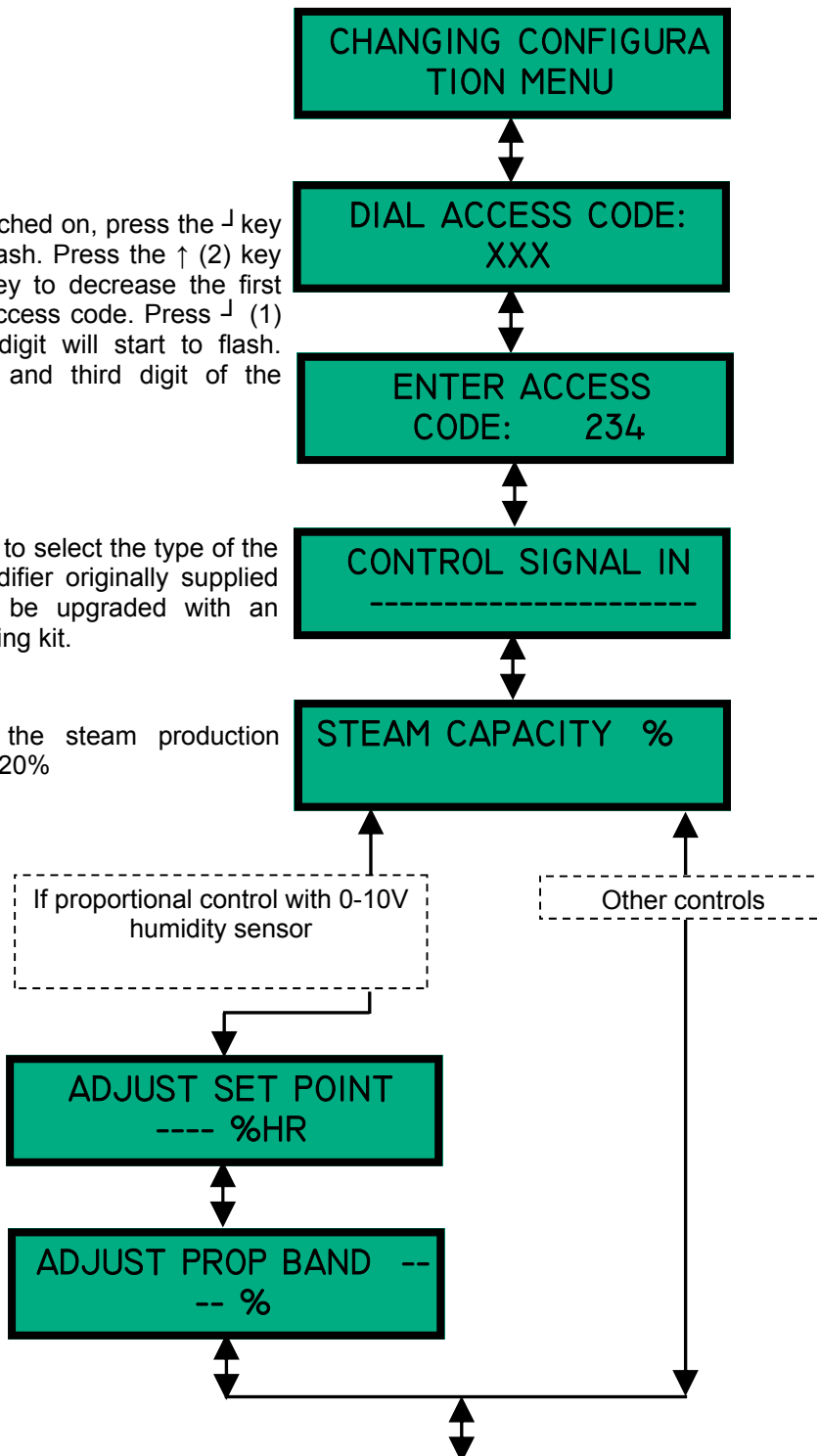



ELECTROVAP MC2

System management

Configuration changing menu

CONTINUED

This allows to adjust the estimated number of produced steam in kg or of working time before a visual control be made. If a cylinder maintenance is to be done, please refer to the cylinder maintenance pages of this manual. If not, this parameter can be adjusted for a higher value (factory default time : 300h).

MAINTENANCE FREQUENCY ----- KG

MAINTENANCE INTERVAL ----- H

This parameter allows to adjust the time of the small drain that takes place whenever the humidifier takes in water. This time can be increased when foam is seen inside the cylinder (particularly when using softened waters).

SHORT DRAIN --- SEC

This allows to shut down the contactor(s) during draining to prevent leakage currents.

CONTACTOR STOP WHEN DRAINING ----

This allows to select how the unit reduces its output : either by evaporation (required for demineralized water) or by draining.

FOAM / SCALE CONTROL : -----

This allows to select the type of cylinder used.

CYLINDER SELECT -----

This allows each unit to be given a reference number when it is connected to a communication bus.

IDENTIFICATION OF ELMC ---

This allows to synchronize the speed data with the ELMC communication bus

SPEED DATA ----- b/s



ELECTROVAP MC2

System management

Configuration changing menu

CONTINUED

This enables or not the function of keeping water temperature of the cylinder at 65°C when the unit is stopped. NB : this function requires that the optional kit be installed.

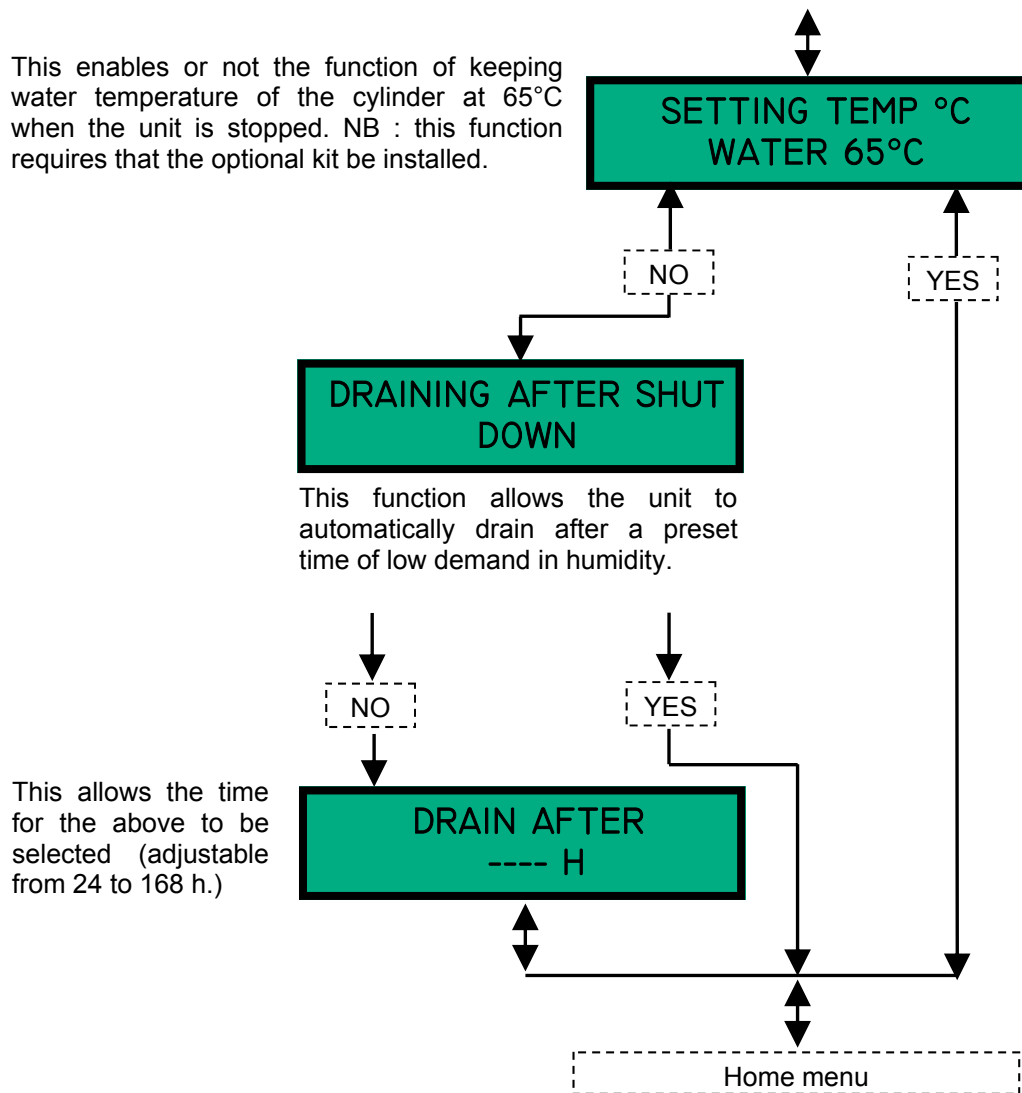

This allows the time for the above to be selected (adjustable from 24 to 168 h.)



IMPORTANT NOTICE

The units have a factory default maintenance time of 300 hours that suits to most cases. The exact maintenance frequency is variable and depends on water quality, hours of run and level of demand for humidification. New installations should be inspected or serviced frequently to enable a suitable maintenance routine to be established.

For hard or very hard waters, the use of a cleanable cylinder is recommended.

A cleanable cylinder maintenance guide can be found on the next page. This should be seen as an help only and not be considered as a binding information from **devatec** in any case.

Estimated cylinder maintenance curve

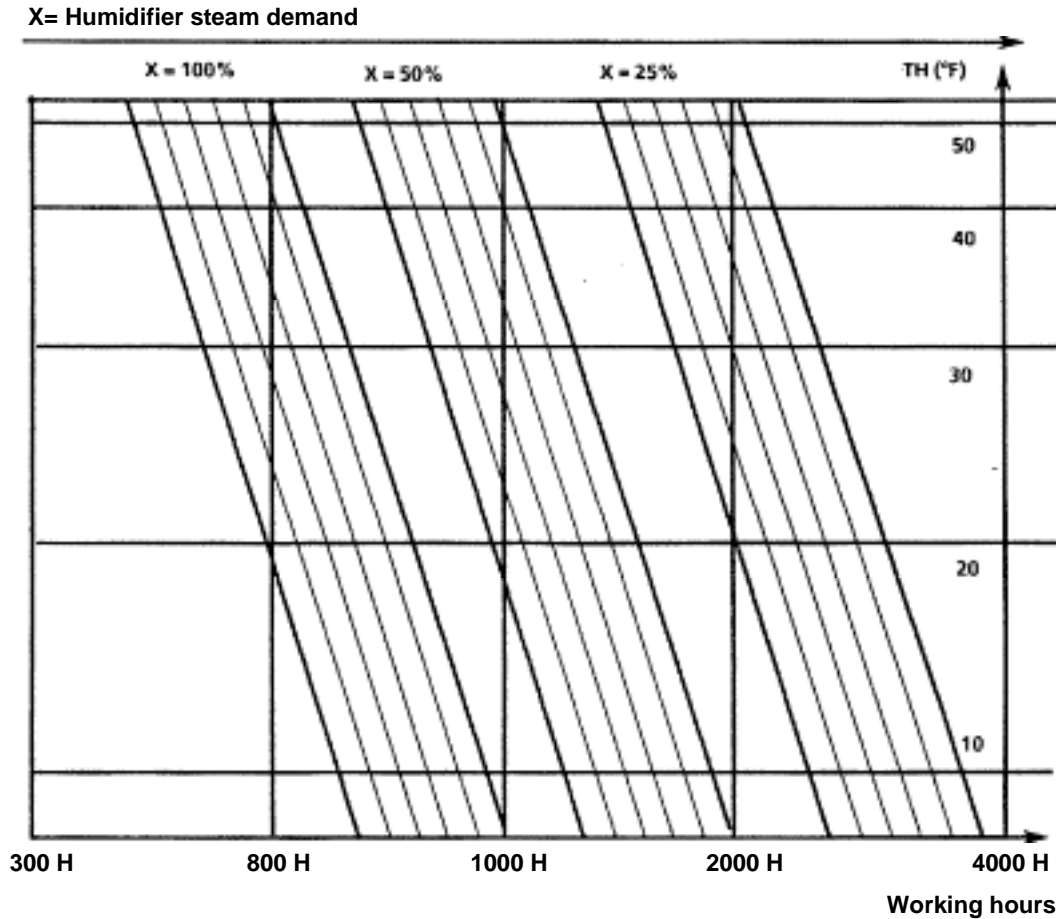

Example given: it is recommended to maintain (if cleanable type) or change (if disposable type) the steam cylinder every 800 to 900 hours of operation for a humidifier running at full capacity and using a water of TH20.

- The water tightness is indicated in French grade, the said value is the water hydrotimetric content (TH).
- The water quality is to be mentioned on your request so that to fit the most appropriate steam cylinder for the best working of the humidifier.

Length of the genuine stainless steel electrode plates

Model	ELMC 5 to 15-2	ELMC 10 single phase	ELMC 20 to 90
Length (mm)	160	270	250



During cylinder maintenance (page n°47), it is recommended to measure the length of the electrode plates. The latter should be replaced when the length is shorter than 1/3 or 1/2 of the original length (s.a. above table).



ELECTROVAP MC2

Maintenance - Check points

ROUTINE SERVICE

- After the humidifier has run for about one hour time, check for any water leakage at the cylinder gasket and at the drain valve.
- The cylinder should be inspected after about 50 hours of run. Make sure there is no arcing nor sparking between the electrodes when the unit is in operation. As well, when switched off, all the contactor screws and the steam, drain and internal hose clamps should be retightened.
- A complete inspection of all the humidifier hoses should be made after one year of operation. Any faulty or damaged hose must be replaced to prevent leakage.

WARNINGS

When the humidifier is used for a long time or operates with a very conductive water, solid deposits built-up on the electrode plates which can make the water even more conductive.

If electrical arcs can be seen inside the steam cylinder, the humidifier doesn't operate properly. Switch off the humidifier immediately. This arcing involves :

- Excessive heat on the plastic shells that can eventually make the material melt and make a hole from where scalding water can escape.
- Circuit breaking caused by excessive intensity.
- Faster corrosion of the electrode plates.
- Burning of the electrode power cables.

Points to check in case of arcing

- If the humidifier works with softened water, ensure that the softener does not supply salt water to the humidifier.
- Ensure that the drain valve works properly and clean it up (see after page n° 52).
- Ensure that the F3 drain valve fuse is still in order (ref : 500101/05).

CAUTION

Always isolate all electrical and water supplies to the humidifier before commencing any maintenance and refer to the instructions given in this manual.

The ELMC humidifier includes live electrical components and the steam cylinder contains boiling water. All maintenance must only be carried out by skilled and qualified personnel.

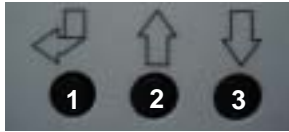

Press **Select button 1** to rotate between the menus and press the up or down buttons to enter the desired menu.

**INSPECTION DUE
50 H - SEE MANUAL**

50 HOURS AFTER SWITCHING ON

- A « 1st inspection see after manual » warning message is shown on the window.
 - The unit works on.
 - The remote maintenance contact is triggered on.
 - The remote general failure contact is off.
-
- To reset the warning message, press key 3 for over 5 seconds
 - This 50 hours timer cannot be suppressed nor modified.

**SERVICE DUE
SEE MANUAL**

SERVICE TIME ELAPSED (service message)

- A « CYLINDER MAINTENANCE - SEE AFTER TECH MANUAL » service message is shown.
- The unit works on.
- The remote maintenance contact is triggered on.
- The remote general failure contact is off.

Maintenance to the cylinder(s) (s.a. page 51) and to the valves (s.a. pages 52-53) should be done.

- This service message is removed only when the manual draining is completed (about 6 mn). The « DRAINING CYCLE OVER » service message is then displayed.
- This timer (300 H factory preset) can be adjusted (access code 2.3.4 : « MAINTENANCE FREQUENCY (HR) » but not removed.

**SERVICE OVERDUE
SYSTEM OFF**

SERVICE TIME OVERDUE (service message)

- If the previous alert has not been cleared, a new alert « SERVICE OVERDUE / SYSTEM OFF » is shown 100 hours thereafter.
- **The humidifier is brought to a halt.**
- The remote maintenance contact is triggered on.
- The remote general fault alert is triggered on.

Maintenance to the cylinder(s) (s.a. page 51) and to the valves (s.a. pages 52-53) must be done.

- This alert message is removed only when the manual draining is completed (in about 6 mn). A « DRAINING CYCLE OVER » message is then shown on the display. Press button 1 to bring the humidifier back to operation.
- This 100 H timer cannot be suppressed nor modified.

**REPLACE CONTACTORS
10000 HR RUN**

CONTACTOR TO REPLACE (service message)

- «10000 H REPLACE CONTACTOR» is shown after the humidifier has been running for 10000 hours. This means that the contactor(s) has/have been triggered on and off for 10000 hours and that its/their replacement is/are highly recommended.
 - The unit works on.
 - The remote maintenance contact is triggered on.
 - The remote general fault contact is triggered on.
-
- To reset this alert message, press key 3 for over 5 seconds
 - This 10000 H timer cannot be suppressed nor modified.

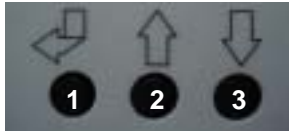

Press **Select button 1** to rotate between the menus and press the up or down buttons to enter the desired menu.

CONTACTOR COIL FAILURE P1

« CONTACTOR COIL FAILURE P1 » ALERT

- When the alert « CONTACTOR COIL FAILURE P1 » is shown, the humidifier is stopped and the remote general fault contact is triggered on (the remote maintenance contact is kept off).
- Check : F1 (2A) fuse, contactor coil(s), connection of wires at terminals 13 & 14 and attachment of X4 connector onto the main board.
- The only way to remove the alert is to trace the cause of the failure and solve the problem (check contactor(s) order). Switching off the humidifier will clear the window only but will not remove the failure message which will be shown again 4 mn after the humidifier redetects the failure.
- This fault can be disabled inside the menu (please contact your authorized distributor). This will suppress the detection.
- Simulation : disconnect connector X4 from main board while the contactor is activated. The failure is detected 4 mn afterwards.

SEE CONTACTOR BLOCKED P2

« CONTACTOR BLOCKED P2 » ALERT

- When a « CONTACTOR BLOCKED P2 » information is shown, this means that the cylinder power electrodes are still supplied though the humidifier is on a halt.
- CAUTION : switch the humidifier off before any handling !**
- Status : unit off—remote general fault alert initiated—remote maintenance alert off.
- Items to check : contactor(s) order.
 - The only way to remove the alert is to trace the cause of the failure and solve the problem (check contactor(s) order). Switching off the humidifier will clear the window only but will not remove the failure message which will be shown again 2 mn after the humidifier redetects the failure.
- Simulation : jump connector X4 of the main board when the unit is stopped (demand = 0%) - The failure is detected and a message is displayed after 2 mn.

LEAKAGE : INLET WATER VALVE P3

« INLET WATER VALVE P3 » ALERT

- When this alert is shown, the remote general fault alert contact is activated. The humidifier goes on working. The remote maintenance contact is kept off.
- Item to check : water at the base of the cylinder
- Switching off and on will clear the message only for a short while from display but will not remove the alert (s.a. page 53). It will reappear after the humidifier detects the fault again 20 mn afterwards.
- This fault can be disabled inside the menu (please contact your authorized distributor). This will suppress the detection.
- Simulation : constantly supply the inlet valve in 230 V.

NO INLET WATER P4

« NO INLET WATER P4 » ALERT

- a « NO INLET WATER P4 » information is shown when the cylinder is not correctly filled. In this case, the humidifier is stopped and the remote general fault alert is initiated. The remote maintenance alert is kept off.
- Items to check : F2 inlet valve fuse, drain valve (could be clogged by pieces of calcius) - steam hose (pockets of water) - power voltage—TI voltage reading (condition of the torroidal of intensity—power wire passing through TI hole).
- Reset : switching off and on the humidifier will clear the display but will not remove the message which will be shown again after a while. .
- This fault can be disabled inside the menu (please contact your authorized distributor). This will suppress the detection.
- Simulation : Tap off the water supply. Time before detection : about 8 mn.

SEE : DRAIN CIRCUIT P5

« SEE DRAIN CIRCUIT P5 » ALERT

- This alert is shown when the draining is incorrectly operated. In this case, the humidifier is stopped and the remote general fault alert is initiated. The remote maintenance alert is kept off.
- Items to check : F3 fuse (if found faulty, replace fuse and drain valve solenoid), correct water draining by pressing manual drain button). If no drain, clean cylinder and draining circuit.
- Reset : switching off and on the humidifier will clear the display but will not remove the message which will be shown again after a while.
- This fault can be disabled inside the menu (please contact your authorized distributor). This will suppress the detection.
- Simulation : disconnect the solenoid coil of the dain valve. Time before detection : sereval hours.

LEAKAGE WATER DETECTION P6

« WATER LEAKAGE DETECTION P6 » ALERT

- **REMINDER** : to enable this function, the optional water leakage detection board should be installed first.
- When the alert message is shown, the remote general fault alert is initiated, the cylinder is drained fully and the humidifier is brought to a halt. The remote maintenance alert contact is kept off.
- Items to check : water at the water sensor in the humidifier humidity compartment.
- Switching off and on the humidifier will clear the message only for a while but will not remove the alert which will be shown again 15 seconds after the humidifier detects it again.
- This fault can be disabled inside the menu (please contact your authorized distributor). This will suppress the detection.
- Simulation : drop a water drop on the water sensor.

CLEAN CYLINDER + DRAIN VALVE P8

« CLEAN CYLINDER + DRAIN VALVE P8 » ALERT

- This alert is shown when the draining cannot be operated. In this case, the humidifier is stopped and the remote general fault contact is triggered on. The remote maintenance contact is kept off.
- Items to check : F3 fuse (if found faulty, replace it and replace drain valve solenoid coil); operate a manual draining to control correct water flowing. If incorrect, check or replace cylinder and water piping.
- Switching off and on will clear the message only for a while from the display but will not remove the alert which will be detected and displayed again some minutes after.
- This fault can be disabled inside the menu (please contact your authorized distributor). This will suppress the detection. - Simulation : generate over currents

Transformer of intensity (TI)

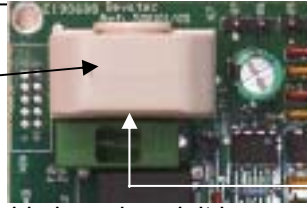

Main board ref:
500101/05

Power cable hole in
transformer



When the PCB or a power cable is replaced, it is essential for correct operation to use the method of wiring appropriate to your exact model of humidifier.

For humidifiers with multiple cylinders, wire up each corresponding Torroidal Transformer with relevant method.

TORROIDAL TRANSFORMER WIRING METHOD

ElectroVap MC2 from 208V to 230V												
	5	5	8	10	10_2	15-2	20	30	40	50	60	70
Nb of phases	1	3	3	3	1	3	3	3	3	3	3	3
Method n°1	X	X	X	X								
Method n°3					X	X	X	X	X	X	X	X

ElectroVap MC2 from 380V to 690V													
	5	8	10	15-2	20	30	30HC	40	50	60	60HC	90	90HC
Nb of phases	3	3	3	3	3	3	3	3	3	3	3	3	3
Method n°1		X	X	X	X			X					
Method n°2	X												
Method n°3						X	X		X	X	X	X	X

Method n°1

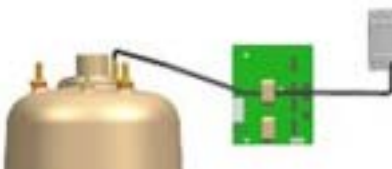

The power cable is run once through the toroidal transformer, then into the contactor.

Method n°2

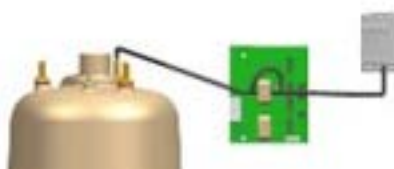

The power cable is once run through and looped over the toroidal transformer and back through the transformer hole. Fix the cable into the contactor.

Method n°3



Use the specialised split power cable. Run one of the power cable cores once through the toroidal transformer then into the contactor. Run the second power cable core directly to the contactor.

CONNECTING THE TI POWER CABLE INTO THE CONTACTOR

ELMC 5 to 30

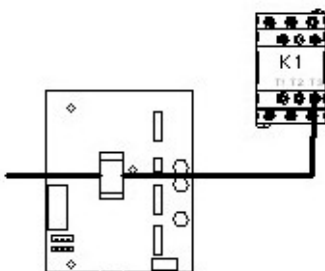

ELMC 40 to 60

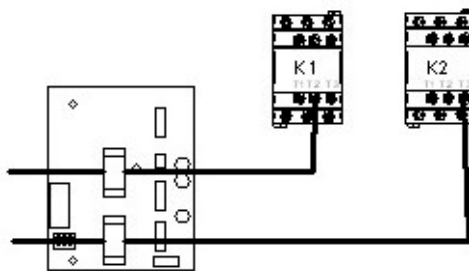

ELMC 70 to 90

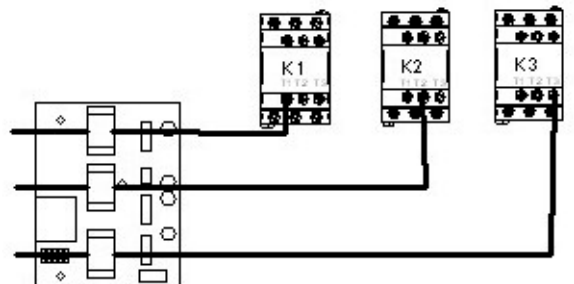

The power cable identified with a brown sticker must be connected into the T1 terminal of the contactor.



ALL WORKS CONCERNED WITH ELECTRICAL INSTALLATION MUST BE CARRIED OUT BY A SKILLED AND QUALIFIED PERSONNEL



The ELMC humidifiers are currently fitted with disposable cylinder (s).The latter can however be easily substituted for cleanable type at customer's choice.

REPLACING THE STEAM CYLINDER



Drain the steam cylinder(s) fully using the manual drain key. When the cylinder(s) is/are drained fully (a « DRAINING CYCLE OVER » will appear on the display). Isolate the power both at the general switchboard and at the humidifier (rocker power switch).



The steam cylinder(s) may be very hot. Allow it/them to cool down before removing.



Remove the front panel from the humidifier to access the cylinder compartment. Remove power and high water level electrode cables from top of the cylinder(s) (picture 1).

Disconnect the steam hose(s) from the top of the cylinder(s) (pict. 2).



Lift the cylinder upwards until it is clear off the drain valve. Ensure that the gasket remains in the drain valve (picture 3).

Release the top of the cylinder from the retaining clip and pull out the cylinder (picture 4).

The disposable cylinder(s) will be merely replaced by new ones either disposable or cleanable.

Retighten gently the steam hose on the cylinder outlet when the cylinder has cooled down only to prevent deformation.

CLEANING THE CLEANABLE STEAM CYLINDER

This method is intended for use with the cleanable cylinder only.

- Mark the edge of the cylinder halves so that they can be matched up when reassembled (picture 5).
Remove the maintaining nuts and bolts, split the cylinder halves and remove the gasket and the strainer that must be cleaned (pict 6).
- Scrap mineral deposits off the electrode plates and the shells (a weak descaling solution can also be used) (pictures 7, 8 & 9).
- Rinse the electrodes, the cylinder shells and the divider. It is important that the strainer at the cylinder bottom be also cleaned.



Take care : never chock the shell rims to get rid of the deposits



Relocate the strainer into the cylinder bottom. **Replace the cylinder gasket**, and fit it inside the groove of the lower shell and attach the upper shell with the electrodes .



When re-assembling, take care to align both shells. Refit the bolts and nuts. Retighten them gently (when the cylinder is still cold). Rinse the drain valve 'o' ring and grease it or replace it if needed.

Important



At this stage, the drain valve must be maintained.

NB : Refit the cylinder to the humidifier once the drain valve is maintained.

DRAIN VALVE MAINTENANCE



The drain valve should be maintained whenever the steam cylinder is maintained or changed.



Once the steam cylinder has been pulled out (please refer to the « cleaning of the steam cylinder » page), disconnect the drain valve supply wires.



Unscrew the solenoid retaining nut and remove the washer. Put them on the cylinder compartment tray.



Remove the coil from the valve stem.



Unscrew and remove the valve stem and the filling hose from the valve body.

Important : Apply some soap on the O-ring and the cylinder draining outlet



Remove the « O » ring and the drain valve collar. Remove any pieces of calcius, rinse the steam and the body with fresh water.

Assemble in reverse order.

It is now time to locate the new or cleaned steam cylinder in its compartment in proceeding this way : set the maintaining clip on the steam cylinder outlet, engage the drain outlet into the drain valve and push the cylinder downward. Reconnect the power cables. Make sure that the power cable with the brown identification mark be connected to the cylinder connection identified with a brown spot. If the brown spot is missing, the cylinder electrode connection can be identified as the one closest to the high water level probe. Locate the steam hose and fasten the clamp.



Ensure that all the clamps are properly tightened whenever the humidifier is maintained.

INLET VALVE MAINTENANCE



The inlet valve should be maintained every 6 months as a minimum and after 50 hours operation.



①

Isolate the water supply and remove the water supply hose from the valve.



Disconnect the electrical wires from the coil.



Untighten the collar clamp and remove the water feed hose.

Unscrew the black nut  and lay it on the cylinder compartment tray.



Take the valve out and remove the basket filter from the base of the valve with a pair of long nose pliers. Pull the coil out with a flat screw driver.



Wash the basket filter under clean water to remove any dirt and debris.

Replace whole valve if cleaning is not practical or replace coil if necessary.

Assemble in reverse order taking care to replace collar clamp if necessary.

Ensure that everything is correctly assembled and switch the humidifier on.



Ensure that all the clamps are properly tightened whenever the humidifier is maintained.

Rep	Code	Description
1	930058	Filling cup with hoses for ELMC 1 small sized cylinder
	930059	Filling cup with hoses for ELMC 1 large sized cylinder
	930060	Filling cup with hoses for ELMC 2 cylinders
	930061	Filling cup with hoses for ELMC 3 cylinders (left hand side)
	930062	Filling cup with hoses for ELMC 3 cylinders (right hand side)
2	930301	Hose clamp Ø25x40mm
	930302	Hose clamp Ø40x60mm
3	930085	Power cable kit n° 1 (3 single cables with sockets and boots)
	930086	Power cable kit n°2 (2 single cables + 1 split cable with sockets and boots)
	930087	Power cable kit n° 3 (3 single cables + 1 split cable with sockets and boots)
4	930079	Cylinder retaining clip ELMC small sized cylinder
	930080	Cylinder retaining clip ELMC large sized cylinder
5	930088	High water level electrode cable ELMC 1 cylinder
	930089	High water level electrode cable ELMC 2 cylinders
	930090	High water level electrode cable ELMC 3 cylinders
6	930136	Overflow hose Ø18/22mm (per meter)
7	930136	Water feed hose Ø18/22mm (per meter)
8	930189	Bag of 10 drain valve O-rings
9	930153	230V complete drain valve
	930307	Plastic drain valve body
	930220	Drain valve stem with 230V solenoid
	930161	230V solenoid
10	930072	Drain cup upper half ELMC 1 cylinder, 2 cylinders left hand side, 3 cylinders right hand side
	930074	Drain cup upper half ELMC 2 cylinders right hand side, 90 middle
	930075	Drain cup upper half ELMC 3 cylinders left hand side
11	930078	Drain cup lower half
12	930084	Water inlet hose
13	930150	Inlet valve ELMC 1 small sized cylinder
	930151	Inlet valve ELMC 1 large sized cylinder
	930152	Inlet valve ELMC 3 cylinders
	930160	230V inlet valve solenoid
14	930081	Hose clamp Ø12x22mm
	930082	Hose clamp Ø16x27mm
	930083	Hose clamp Ø20x32mm
15	930135	Water feed hose Ø12/16mm (per meter)

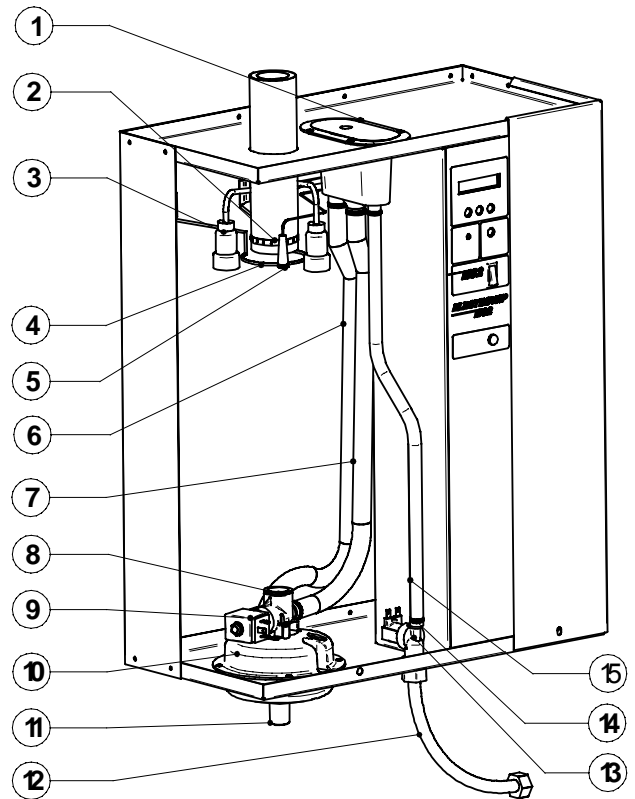

Rep	Code	Description
13	930190	Brass nut Ø8mm
14	930301	Bag of 3 fibre washers
15+18	930211	High water level electrode + nut Ø4mm
16		Cylinder upper half—Please consult factory
17	930203 930223	Bag of bolts & nuts ELMC small sized cylinder (cleanable cylinder) Bag of bolts & nuts ELMC large sized cylinder (cleanable cylinder)
19		Cylinder maintenance kit ELMC 5 to 15-2 Cylinder maintenance kit ELMC 20 to 90
20	930162 930166	Cylinder gasket ELMC small sized cylinder Cylinder gasket ELMC large sized cylinder
21	930169	Electrode plate divider ELMC large sized cylinder
22	930168 930159	Cylinder strainer ELMC small sized cylinder Cylinder strainer ELMC large sized cylinder
23		Cylinder lower half—please consult factory

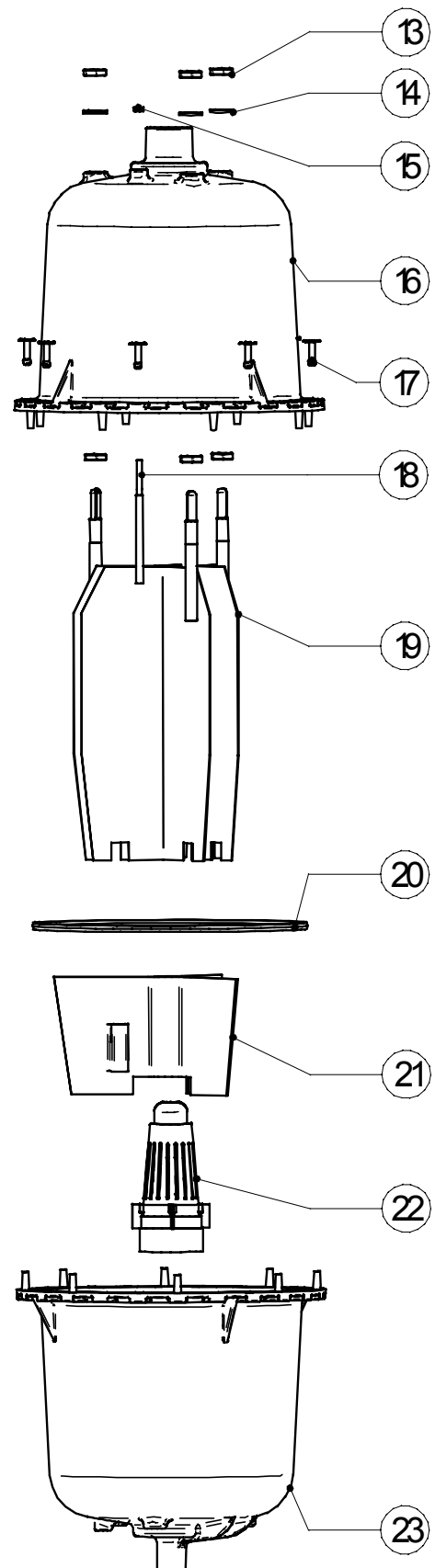

- In standard production, the humidifiers are fitted with disposable cylinder(s)
- EA= Softened water

Rep	Code	Description
24	930010	Small sized disposable cylinder
	930020	Small sized isposable cylinder EA
24	930028	Small sized cleanable cylinder
	930037	Small sized cleanable cylinder EA

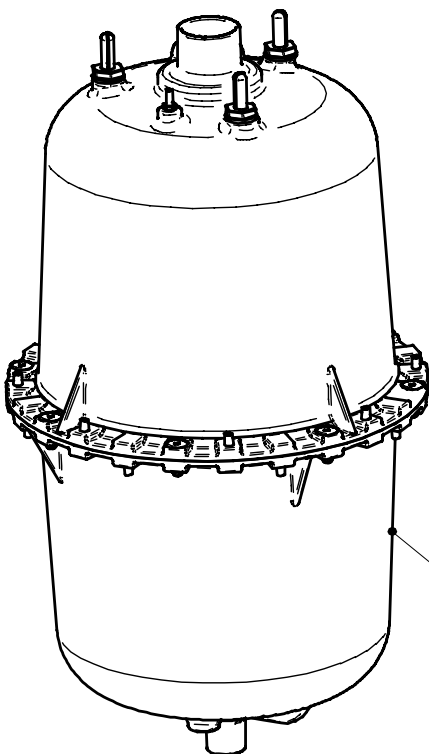
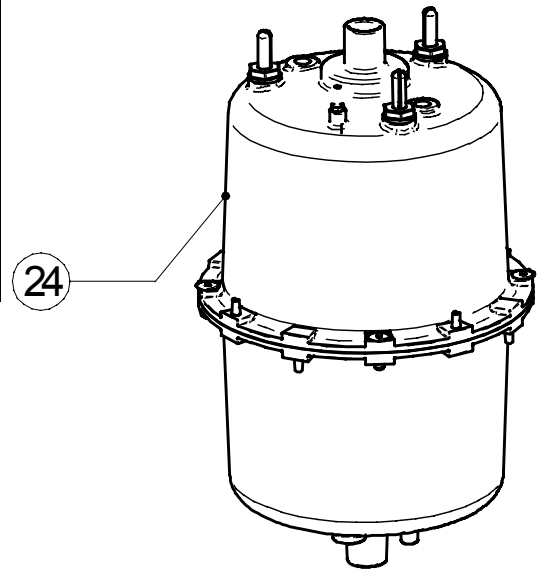

Rep	Code	Description
25	930014	Large sized disposable cylinder
	930023	Large sized disposable cylinder EA
25	930032	Large sized cleanable cylinder
	930040	Large sized cleanable cylinder EA

Rep	Code	Description
26	930101	ELMC digital display (réf: 500600/03)
27	930104	Auxiliary board ELMC 40-50-60 (réf: 500301/05-2TI)
	930105	Auxiliary board ELMC 90 (réf: 500301/05-3TI)
28	930091	Power contactor D18
	930207	Power contactor D25
	930093	Power contactor D32
	930283	Power contactor DPE32P7
29	930100	On/off rocker switch
30	930099	Stand-by power lamp
31	930154	Main PCB ELMC 5 to 30 (réf: 500101/05)
	930103	Main PCB ELMC 40 to 90 (réf: 500101/05)
32	930106	ELMC remote board (réf: 500400/02)

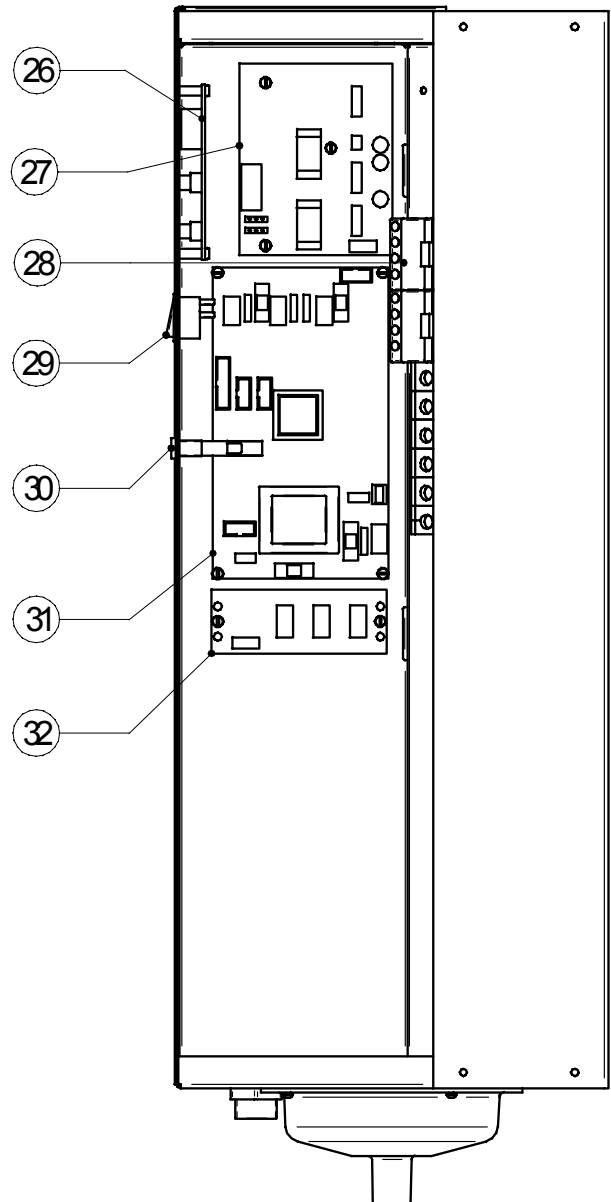



87 Rue Feu St Eloi
76550 Ambrumesnil - France

Export division: tel. +33 (0)2 35 83 06 44 or +33 (0)2 35 83 03 86
fax. +33 (0)2 35 85 36 72
Email: export@devatec.com - www.devatec.com

France division : tel. 02 35 04 61 41- fax. +33 (0)2 35 85 36 72
Email: france@devatec.com - www.devatec.com



devatec reserves the right to change specifications or design of the equipment described in this brochure without prior notice.